

B-1097

Diverter Valve

Installation Instructions

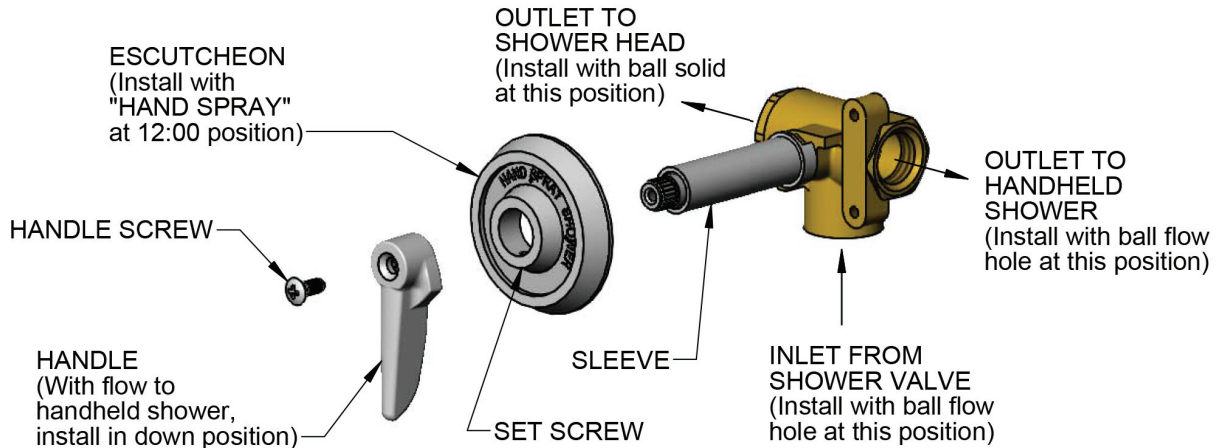

TOOLS NEEDED

- #2 Phillips screwdriver
- 5/64" Hex key wrench

INSTALLATION

1. With the valve in an upright "T" position, make sure the internal ball flow holes are at the bottom (Inlet) and right (Handheld Shower) threaded ports. The left (Shower Head) port will show the polished ball.
2. Remove the handle screw and handle.
3. Remove escutcheon and sleeve.
4. Rough-in the valve in an upright "T" position.
5. After wall is finished, slide the sleeve onto the valve spindle until bottomed. The sleeve slot should nest over the valve hex and not rotate.
6. Loosen but do not remove the set screw to push the escutcheon against the finished wall. The "HAND SPRAY" marking on the escutcheon should be at the 12 o'clock position. Tighten set screw.
7. Reinstall the handle in the down position.

Note: Although normal operation only requires 90 degrees of handle rotation, the handle can turn a full 360 degrees.

8. Test for proper flow to the handheld shower spray then to the shower head. If the flow does not match the handle positions, turn the handle until flow is to the handheld shower only then reposition the escutcheon and handle as described above in steps 6 and 7.

Limited One Year Warranty

T&S warrants to the original purchaser (other than for purposes of resale) that such product is free from defects in material and workmanship for a period of one (1) year from the date of purchase. During this one-year warranty period, if the product is found to be defective, T&S shall, at its options, repair and/or replace it. To obtain warranty service, products must be returned to...

*T&S Brass and Bronze Works, Inc.
Attn: Warranty Repair Department
2 Saddleback Cove
Travelers Rest, SC 29690*

Shipping, freight, insurance, and other transportation charges of the product to T&S and the return of repaired or replaced product to the purchaser are the responsibility of the purchaser. Repair and/or replacement shall be made within a reasonable time after receipt by T&S of the returned product. This warranty does not cover Items which have received secondary finishing or have been altered or modified after purchase, or for defects caused by physical abuse to or misuse of the product, or shipment of the products.

Any express warranty not provided herein, and any remedy for Breach of Contract which might arise, is hereby excluded and disclaimed. Any implied warranties of merchantability or fitness for a particular purpose are limited to one year in duration. Under no circumstances shall T&S be liable for loss of use or any special consequential costs, expenses or damages.

Some states do not allow limitations on how long and implied warranty lasts or the exclusion or limitation of incidental or consequential damages, so the above limitations or exclusions may not apply to you. Specific rights under this warranty and other rights vary from state to state.

Attention California Residents:

“WARNING: This product contains chemicals known to the State of California to cause cancer, and birth defects or other reproductive harm.”

T&S Brass and Bronze Works, Inc. · 2 Saddleback Cove · P.O. Box 1088 · Travelers Rest, SC 29690
www.tsbrass.com · E-mail: tsbrass@tsbrass.com · Phone (800) 476-4103 · Fax (800) 868-0084

West Coast Sales and Distribution · 4596 Ish Drive · Unit 220
Simi Valley, CA 93063 · Phone (800) 423-0150

098-019232-45	Rev. 0
Drawn	TEH 07-21-15
Checked	DMH 07-28-15
Approved	JHB 08-04-15