



SERVICE PARTS LIST

BULLETIN NO.
54-06-2145

SPECIFY CATALOG NO. AND SERIAL NO. WHEN ORDERING PARTS		REVISED BULLETIN	DATE
M18™ RADIUS™ LED COMPACT SITE LIGHT			July 2018
CATALOG NO. 2145-20	STARTING SERIAL NO.	H48A	
		WIRING INSTRUCTION	

EXAMPLE:
Component Parts (Small #)
Are Included When Ordering
The Assembly (Large #).

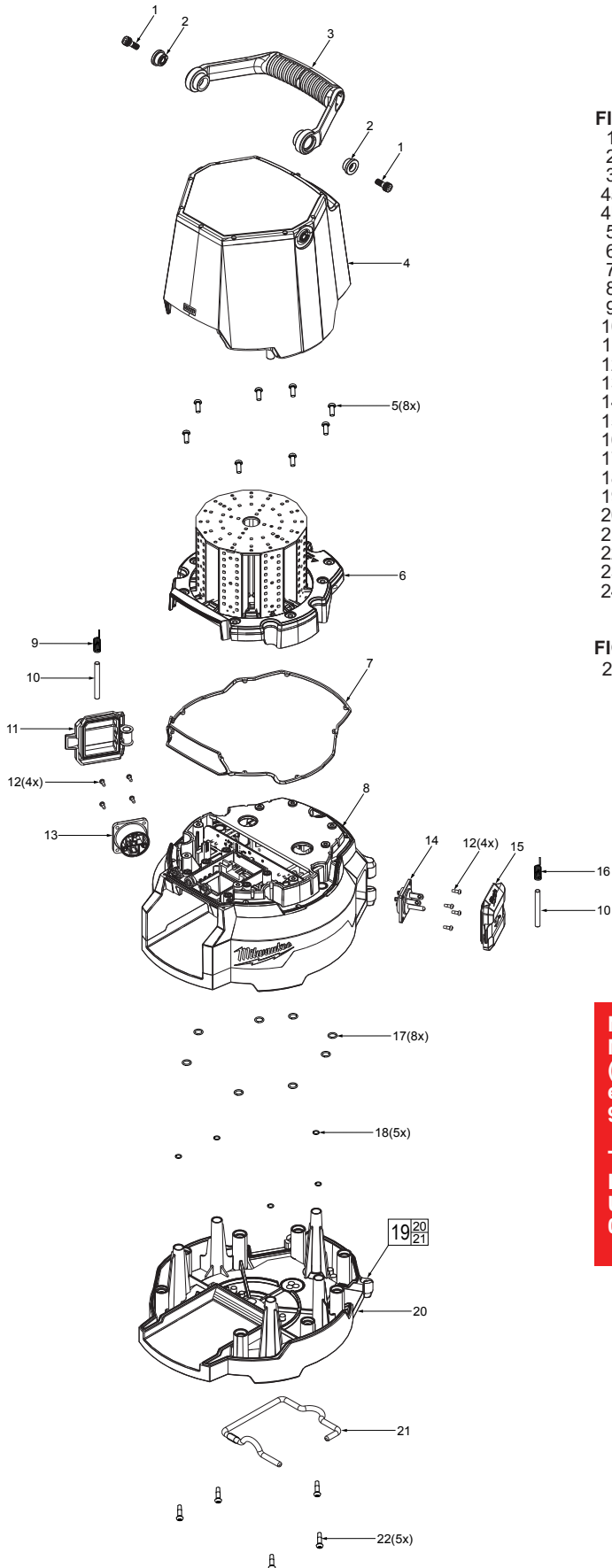

FIG.	PART NO.	DESCRIPTION OF PART	NO. REQ.
1	06-82-2005	M6 x 12 Screw	(2)
2	42-40-0165	Bushing	(2)
3	43-62-0095	Handle	(1)
4a	44-06-0005	Clear Lens Assy. w/ Screws	(1)
4b	44-06-0045	Diffused Lens Assy. w/ Screws	(1)
5	05-88-1360	M4 x 13.5 Screw	(8)
6	23-28-0040	LED Console Assy.	(1)
7	43-40-0040	Sealing Ring	(1)
8	-----	Base	(1)
9	40-50-2005	AC Outlet Cover Spring	(1)
10	44-60-0475	Cover Pin	(2)
11	23-33-0540	AC Outlet Cover	(1)
12	06-82-1087	M3 x 12 Screw	(8)
13	23-33-0535	AC Outlet	(1)
14	23-33-0545	AC Inlet	(1)
15	23-33-0530	AC Inlet Cover	(1)
16	40-50-2006	AC Inlet Cover Spring	(1)
17	34-40-0340	O-Ring 1.5mm	(8)
18	34-40-0345	O-Ring 1.0mm	(5)
19	14-38-0040	Bottom Cover Assy.	(1)
20	-----	Bottom Cover	(1)
21	43-74-0005	Bottom Cover Hook w/ Rubber Tube	(1)
22	05-81-1215	M4 x 22 Screw	(5)
23	12-20-2145	Service Nameplate (Not Shown)	(1)
24	42-44-0025	Security Cable (Not Shown)	(1)

FIG. NOTES
23 A clean, dry surface is essential for proper performance for any adhesive system. The area intended for application of any adhesive label or nameplate must be prepared by cleaning with isopropyl alcohol. The solvent is to be applied with a clean, lint free applicator and the surface allowed to dry before applying the label or nameplate.

NOTE:
Model 2145-20 M18™ RADIUS LED COMPACT SITE LIGHT (Serial Break 'A') is designed to operate off of several different M18 REDLITHIUM™ battery sizes from a 1.5 amp-hours to 9.0 amp-hours.

To power a 2145-20 M18™ RADIUS LED COMPACT SITE LIGHT (Serial Break 'A') with a 48-11-1812 M18™ REDLITHIUM™ 12.0 amp-hour battery, 12.0 Upgrade Service Kit 14-46-0082 must be ordered to accommodate the larger size battery.