

## Model TD-2 Test and Drain Valve 2.8K and 4.2K Test Orifice

### General Description

The TYCO Model TD-2 Test and Drain Valve with integral pressure relief as shown in Figure 2 provides a simplified means for testing of waterflow alarm devices and draining of feed mains. The valve is typically utilized for connection to a common inside drain where it is not practical to terminate an inspector's test connection outside of a building.

The Model TD-2 valve features a 2 in. NPT connection with a 4.2 K-factor orifice, and 1 1/4 in. NPT connection with a 2.8 K-factor orifice.

Additional features of the Model TD-2 include:

- Linear shut-off eliminates leakage due to debris in media
- Integral pressure relief
- Installation in any position
- Self-cleaning sight glass provides positive indication of flow

#### NOTICE

*The TYCO Model TD-2 Test and Drain Valve described herein must be installed and maintained in compliance with this document, as well as with the applicable standards of the NATIONAL FIRE PROTECTION ASSOCIATION (NFPA), in addition to the standards of any other authorities having jurisdiction. Failure to do so may impair the performance of these devices.*

*The owner is responsible for maintaining their fire protection system and devices in proper operating condition. Contact the installing contractor or product manufacturer with any questions.*



### Technical Data

#### Approvals

UL and ULC Listed  
FM Approved  
Listed by California State Fire Marshall

#### Maximum Service Pressure

300 psi (20,7 bar)

#### Shut-Off Valve

Linear stem actuation with EPDM rubber seals

#### Test Orifice

Linear stem actuation offered in 2.8K and 4.2K test orifices

#### Sight Glass

Dual sight glasses. NPT threaded.

#### IMPORTANT

Refer to Technical Data Sheet TFP2300 for warnings pertaining to regulatory and health information.

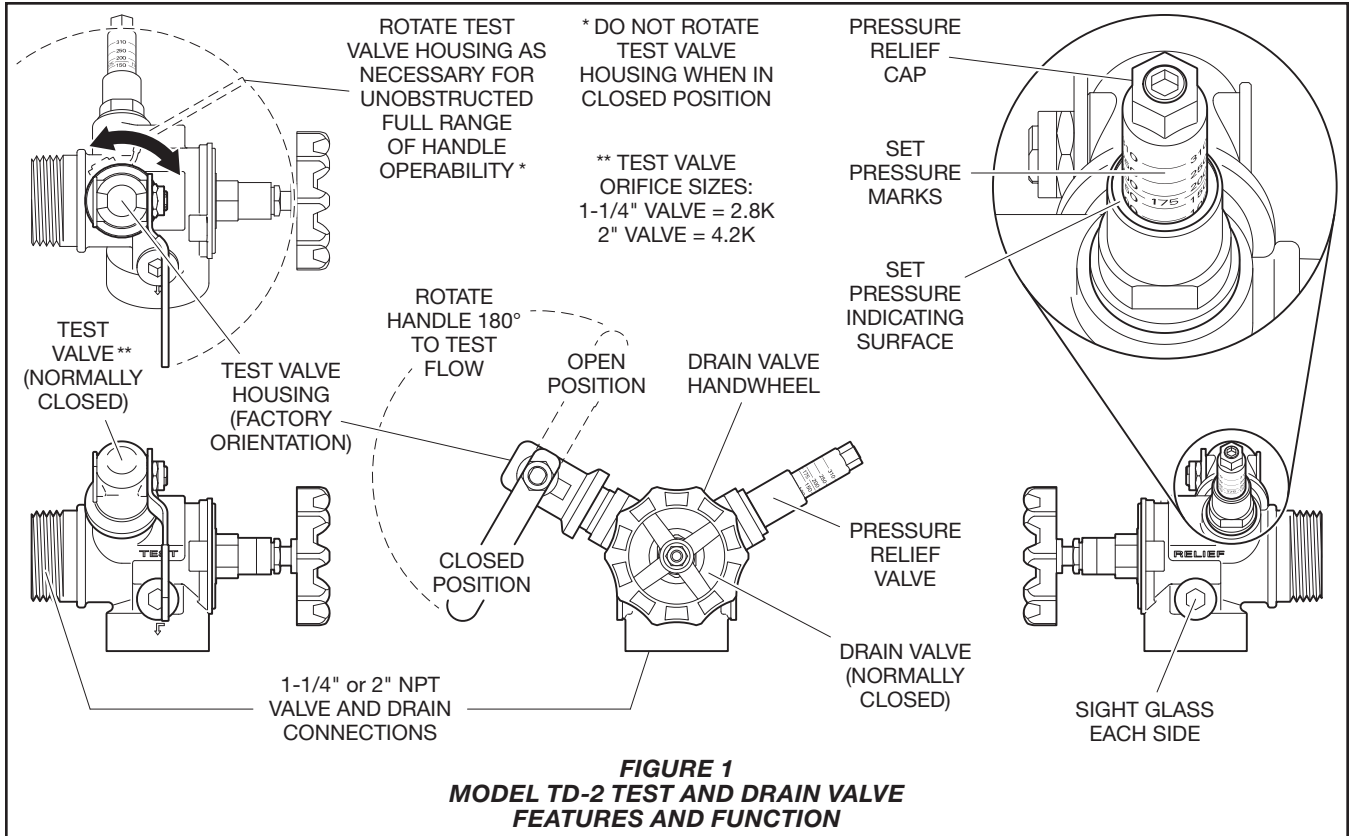

## Installation

The TYCO Model TD-2 Test and Drain Valve must be installed in accordance with this section.

### Notes:

- The Model TD-2 valve must be installed in a readily visible and accessible location, preferably not over 7 ft (213,4 cm) above the floor.
- Wet pipe fire protection systems must be maintained at a minimum temperature of 40°F (4.4°C).
- The outlet of the Model TD-2 valve must be connected to a drain sized to accept full flow during a sectional flow test.

### Installing the Test and Drain Valve

**Step 1.** Apply pipe thread sealant sparingly to male pipe threads only. Use of a TEFLON sealant is recommended.

**Step 2.** The valve may be installed in any orientation; however, the arrow on the assembly must point in the direction of flow - towards the drain - and there must be no restriction to the full movement of the valve handles as shown in Figure 2.

### Setting the Pressure Relief Valve

**Step 1.** Review the pressure relief valve assembly on the test and drain valve as shown in Figure 1.

**Step 2.** Rotate the pressure relief cap and align the set pressure marks to the set pressure indicating surface plus (+) or minus (-) a quarter turn.

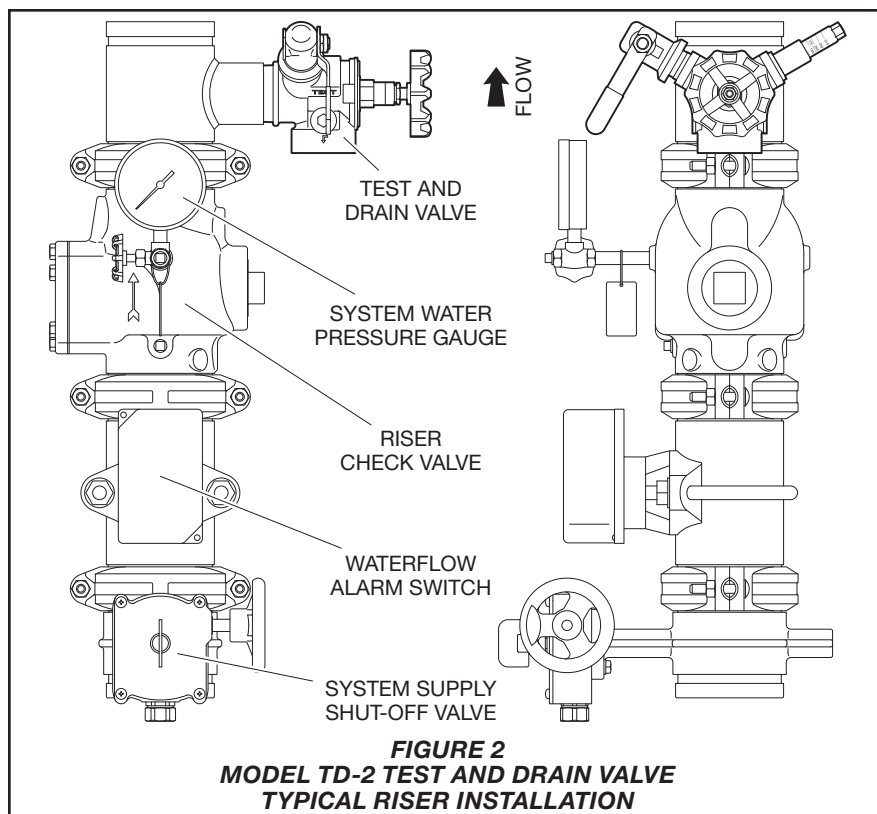

## Care and Maintenance

The Model TD-2 Test and Drain Valve must be maintained and service in accordance with this section.

Before closing a fire protection system control valve for inspection or maintenance work on the fire protection system that it controls, obtain permission to shut down the affected fire protection systems from the proper authorities and notify all personnel who may be affected by this decision.

After placing a fire protection system in service, notify the proper authorities and advise those responsible for monitoring proprietary and/or central station alarms.

Before testing alarms, notification must be given to the owner and the fire department, central station or other signal station to which the alarms are connected.

The owner is responsible for the inspection, testing, and maintenance of their fire protection system and devices in compliance with this document, as well as with the applicable standards of the NATIONAL FIRE PROTECTION ASSOCIATION such as NFPA 25, in addition to the standards of any authority having jurisdiction. Contact the installing contractor or product manufacturer with any questions.

It is recommended that automatic sprinkler systems be inspected, tested, and maintained by a qualified Inspection Service in accordance with local requirements and/or national codes.

The Model TD-2 Test and Drain Valve does not require any regularly scheduled maintenance. However, the following procedure, as applicable and in addition to any specific requirements of the NFPA, may be used to perform an alarm test of a sectional waterflow detector, to perform a sectional flow test; or to drain a section of the sprinkler system, after closing the sectional control valve. Any impairments must be immediately corrected.

**Note:** Do not attempt to repair an impaired TD-2 Test and Drain Valve. The complete assembly must be replaced if there is any indication of malfunction. With the exception of the Sight Glass Assembly and replacement of the Drain Valve Handwheel, no attempt is to be made to disassemble and clean the TD-2 Test and Drain valve.

### Alarm/Flow Test Procedure

**Step 1.** Rotate the Model TD-2 valve handle 180 degrees to the OPEN position as shown in Figure 1.

**Note:** This action permits water to flow through the orifice of the Model TD-2 valve simulating flow from an individual sprinkler located downstream of a Waterflow Alarm Switch as shown in Figure 2.

**Note:** The test valve housing can be rotated 360 degrees to eliminate equipment interference with the test valve handle as shown in Figure 1.

Do not rotate the test valve housing in the closed position.

**Step 2.** Confirm water flow through the test port by observing flow at the drain port sight glass.

**Step 3.** Verify proper operation of the waterflow alarm switch at a fire panel, addressable module and local audible/visual annunciator if installed.

**Step 4.** Rotate the test valve handle 180 degrees back to the CLOSED position.

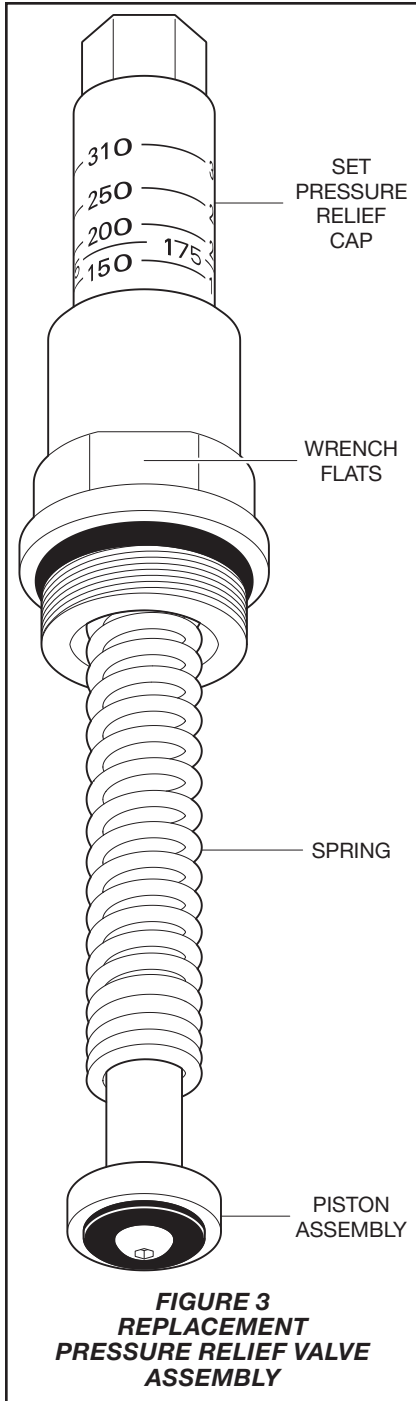

**FIGURE 3  
REPLACEMENT  
PRESSURE RELIEF VALVE  
ASSEMBLY**

### **Pressure Relief Valve Replacement Procedure**

The pressure relief valve assembly may be replaced as necessary. See Figure 3 for valve features described in the following steps.

**Removing the Pressure Relief Valve**  
**Step 1.** Confirm the set pressure relief cap is turned fully counter-clockwise to approximately 0 psi (0 bar).

**Step 2.** Remove the pressure relief valve from the Model TD-2 valve by placing a wrench on the flats, and turning counter-clockwise.

**Step 3.** Remove the relief valve, and extract the piston assembly and the internal spring from the Model TD-2 valve body.

**Note:** *The piston assembly and internal spring are free floating components inside the valve body.*

### **Installing a New Pressure Relief Valve**

**Step 1.** Confirm the set pressure relief cap on the replacement pressure relief valve is turned fully counter-clockwise to approximately 0 psi (0 bar).

**Step 2.** Re-install the new pressure relief valve.

**Note:** *The piston assembly and internal spring are free floating parts. Maintain a slight upward force on them during handling to prevent separation from the relief valve.*

**Step 3.** Hand-grip the wrench flats and apply a slight downward force to compress the internal spring while turning clockwise to engage the threads. Hand tighten by an additional 2 to 3 revolutions.

**Step 4.** Complete the installation using a torque wrench on the wrench flats and tighten to 10 ft-lb (13,6 N·m).

## **Limited Warranty**

For warranty terms and conditions, visit [www.tyco-fire.com](http://www.tyco-fire.com).

## **Ordering Procedure**

Contact your local distributor for availability. When placing an order, indicate the full product name, including description and part number (P/N).

### **Model TD-2 Test and Drain Valve**

Specify: Size (specify) Model TD-2 Test and Drain Valve, P/N (specify)

1 1/4 in. NPT with 2.8K Test Orifice . . . . . 598321  
2 in. NPT with 4.2K Test Orifice . . . . . 598322

### **Replacement Parts**

#### **Replacement Handwheel**

A replacement handwheel may be ordered separately. Specify according to valve size.

Specify: Size (specify) Model TD-2 Test and Drain Valve, Replacement Handwheel, P/N (specify):

1 1/4 in. NPT . . . . . 5940100  
2 in. NPT . . . . . 5940101

#### **Replacement Pressure Relief Valve**

A replacement pressure relief valve may be ordered separately.

**Note:** *The replacement pressure relief valve fits both sizes of the Model TD-2 valve.*

Specify: Size (specify) Model TD-2 Test and Drain Valve, Replacement Pressure Relief Valve, P/N 5940200