



INSTALLATION, OPERATION & MAINTENANCE MANUAL

170-LF 3/8" Compression ASSE 1070



Eco-Mix
Certified
Lead Free



270-LF 1/2" - M-NPT ASSE 1070/1017



Eco-Mix
Certified
Lead Free



370-LF 3/4" - M-NPT ASSE 1070/1017



Eco-Mix
Certified
Lead Free



170-LF WARNING:

DO NOT use thread sealant on compression connections as it will cause damage.

270-LF / 370-LF WARNING:

When using flex hoses be careful, swivel connectors may damage inlet checks and / or element on outlet on 270-LF, 370-LF models. Coupling fittings may be needed if swivel connectors have a brass protruding tube or any protrusion that may damage the valve.

WARNING!!

WATER TEMPERATURES IN EXCESS OF 110°F (43°C) MAY CAUSE SCALDING, SEVERE INJURY, OR DEATH!!

- 1) Valve should be installed where it can be easily cleaned, adjusted or repaired.
- 2) 170 Inlets are furnished with 3/8" compression connections. If using copper tubing, **DO NOT extend tubing more than 1/8" beyond the compression ferrule. DO NOT use thread sealant.**
- 3) Verify tubing is straight, tighten compression nuts by hand, then tighten only 1/4 turn, overtightening will cause leaks and possibly crush checks.
- 4) 270 / 370 Inlets are furnished with NPT connections. When soldering close to this unit, **DO NOT OVERHEAT**, internal components may become damaged.
- 5) Leonard recommends that unions and shutoffs are installed on the inlets and outlet.
- 6) Use solder or pipe cement sparingly. Supply pipes should be flushed before the valve is connected. Flush outlet pipe and valve as soon as it is connected.
- 7) Open hot and cold water supply valves to mixing valve.
- 8) Open mixed water outlet.
- 9) With the fixture in the full open position, calibrate the mixed water outlet temperature by placing a thermometer in the mixed water stream. Loosen knob set screw with 5/64" Allen wrench. Adjust the setting of the valve to obtain the desired temperature (counter-clockwise to increase temperature – clockwise to decrease temperature).
- 10) Tighten knob set screw to lock temperature setting.

PRESSURE-TEMPERATURE:

Maximum pressure: 125 PSI (8.6 BAR)

Maximum hot water temperature: 180°F (82°C)

Hot water inlet temperature range: 120-180°F (49-82°C)

Cold water inlet temperature range: 33-80°F (1-27°C)

Temperature adjustment range: 90-140°F (32-60°C)

IMPORTANT:

Maximum Operating Pressure: 125 PSI (860 KPA)

These thermostatic water mixing valves can be adjusted to deliver water at temperatures exceeding 110°F (43°C). After installation, the installer must check the outlet water temperature and adjust the temperature setting to ensure delivery of a safe water temperature not exceeding 110°F (43°C).

TROUBLESHOOTING INSTRUCTIONS

SYMPTOMS	REPAIR KIT	170-LF	270-LF	370-LF
Leaking water between valve cover and body. Leaking water under knob.	GASKET KIT	1/WX	1/WX	1/WX
Valve will not control temperature after cleaning.	REBUILDING KIT	R/170	R/270/370	R/270/370
Hot water by-passes into the Cold Water Supply Cold water by-passes into the Hot	CHECKSTOP KIT	4/108	4/220	4/320

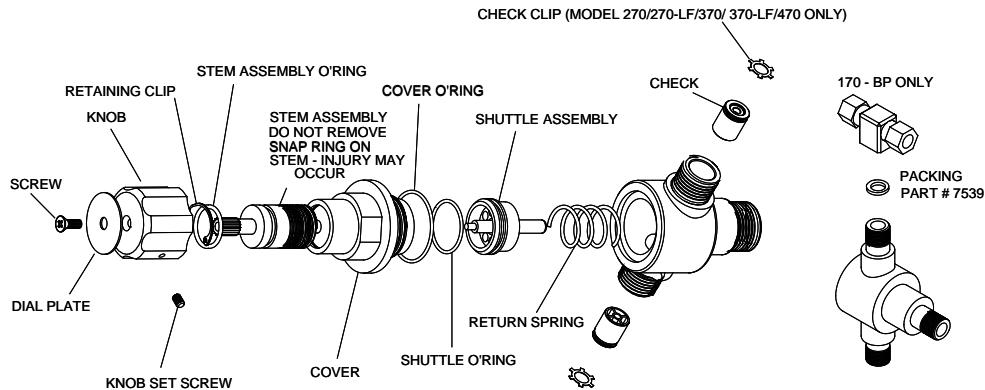

170-LF (3/8" COMP) ASSE 1070	270-LF (1/2" NPT) ASSE1017/ASSE 1070	370-LF (3/4" NPT) ASSE1017/ASSE 1070
<p>1/ WX Gasket Kit Shuttle O-Ring Stem assembly O-Ring Cover O-Ring</p> <p>R/170 Rebuild Kit Return spring Shuttle assembly Shuttle O-Ring Stem assembly O-Ring Cover O-Ring</p> <p>4/108 Check valve Kit 2 Check Valves</p>	<p>1/ WX Gasket Kit Shuttle O-Ring Stem assembly O-Ring Cover O-Ring</p> <p>R/270/370 Rebuild Kit Return spring Shuttle assembly Shuttle O-Ring Stem assembly O-Ring Cover O-Ring</p> <p>4/220 Check valve Kit 2 Check Valves 2 Check Clips</p>	<p>1/ WX Gasket Kit Shuttle O-Ring Stem assembly O-Ring Cover O-Ring</p> <p>R/270/370 Rebuild Kit Return spring Shuttle assembly Shuttle O-Ring Stem assembly O-Ring Cover O-Ring</p> <p>4/320 Check valve Kit 2 Check Valves 2 Check Clips</p>

NO RECIRCULATION

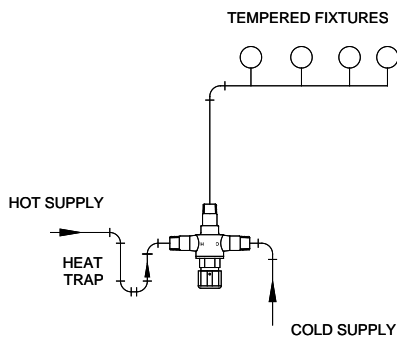

RECIRCULATION

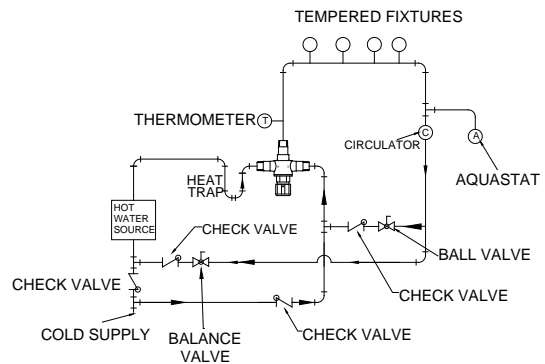

LIMITED WARRANTY

Leonard Valve Company warrants the original purchaser that products manufactured by them (not by others) will be free from defects in materials and workmanship under normal conditions of use, when properly installed and maintained in accordance with Leonard Valve Company's instructions, for a period of one year from date of shipment. During this period the Leonard Valve Company will at its option repair or replace any product, or part thereof, which shall be returned, freight prepaid, to the Leonard factory and determined by Leonard to be defective in materials or workmanship. There are no warranties, express or implied, which extend beyond the description contained herein. There are no implied warranties of merchantability or of fitness for a particular purpose. In no event will Leonard be liable for labor or incidental or consequential damages. Any alteration or improper installation or use of the product will void this limited warranty.