

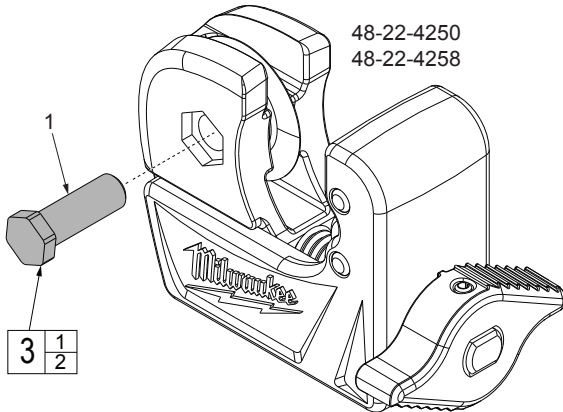

SERVICE PARTS LIST

BULLETIN NO.
54-49-3160

SPECIFY CATALOG NO. AND SERIAL NO. WHEN ORDERING PARTS		REVISED BULLETIN	DATE
TUBING and SWING CUTTERS			Nov. 2021
CATALOG NO.	48-22-4250	1/2" Mini Cutter	See Below
	48-22-4251	1" Mini Cutter	See Below
	48-22-4252	1-1/2" Constant Swing	See Below
	48-22-4258	3/4" Mini Cutter	See Below
	48-22-4253	2-1/2" Quick Adjust Cutter	See Page Two
	48-22-4254	3-1/2" Quick Adjust Cutter	See Page Two
	48-22-4259	1" Constant Swing Cutter	See Page Two



48-22-4250
48-22-4258

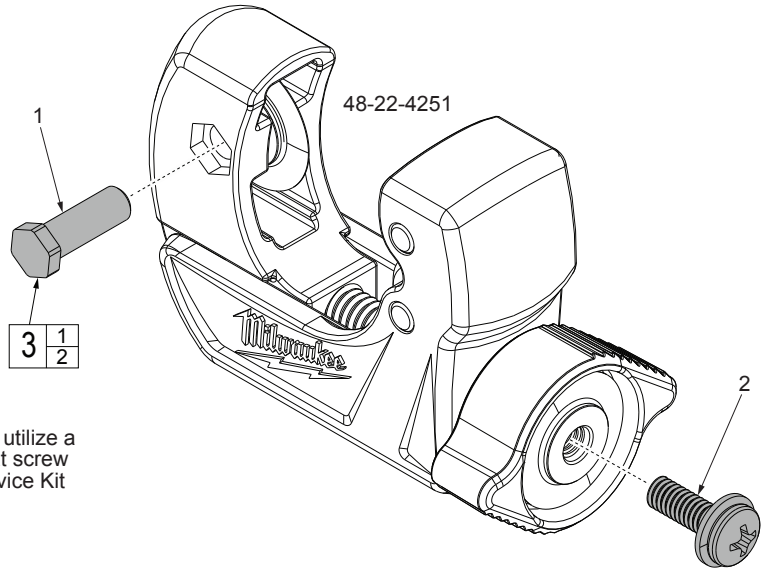

48-22-4251

48-22-4250 and 48-22-4258 do not utilize a Spare Blade Screw (2). Discard that screw when installing the 14-46-4253 Service Kit onto this model.

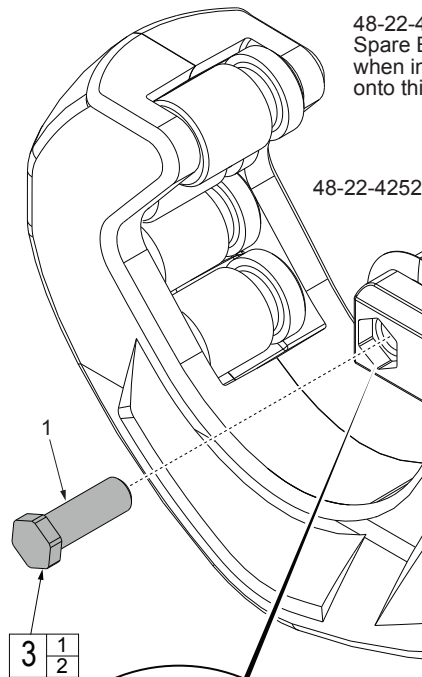

48-22-4252

FIG.	PART NO.	DESCRIPTION OF PART	NO. REQ.
1	-----	Spring Pin	(1)
2	-----	Spare Blade Screw	(1)
3	14-46-4253	Spring Pin / Spare Blade Screw Service Kit	(1)
8	48-22-4256	Replacement Cutter Wheels (Set of 2) (Accessory)	(1)

EXAMPLE:
Component Parts (Small #) Are Included When Ordering The Assembly (Large #).

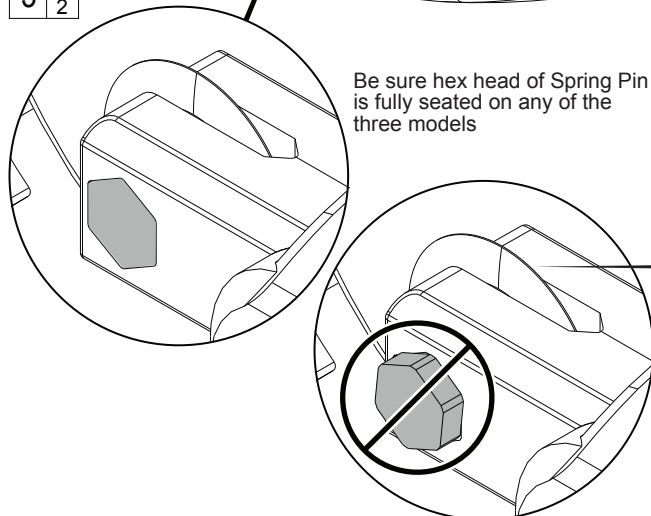

Be sure hex head of Spring Pin is fully seated on any of the three models

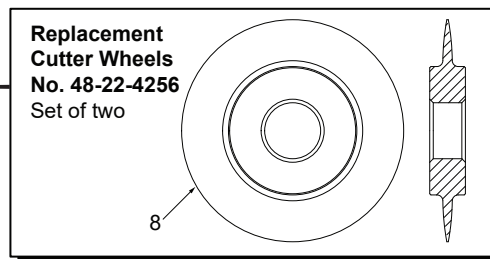

**Replacement
Cutter Wheels
No. 48-22-4256
Set of two**

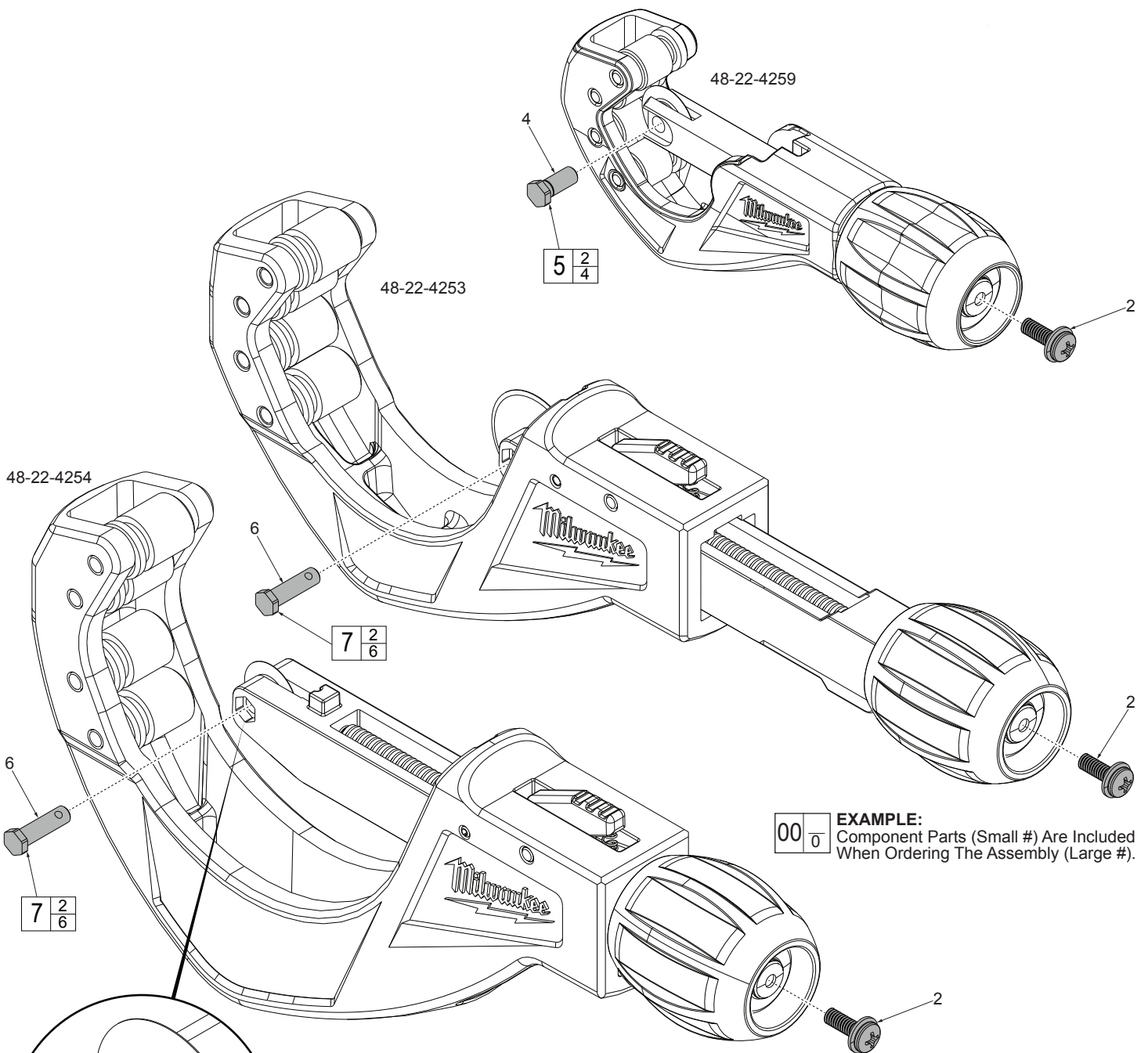

Be sure hex head of Spring Pin is fully seated on any of the four models

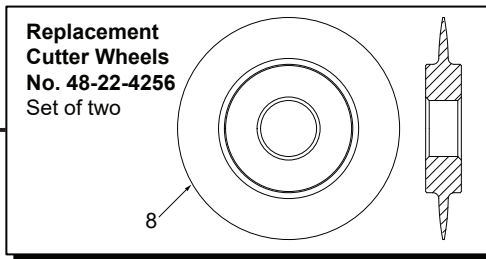

FIG.	PART NO.	DESCRIPTION OF PART	NO. REQ.
2	-----	Spare Blade Screw	(1)
4	-----	Spring Pin	(1)
5	14-46-5301	Spring Pin / Spare Blade Screw Service Kit	(1)
8	48-22-4256	Replacement Cutter Wheels (Set of 2) (Accessory)	(1)

FIG.	PART NO.	DESCRIPTION OF PART	NO. REQ.
2	-----	Spare Blade Screw	(1)
6	-----	Spring Pin	(1)
7	14-46-5302	Spring Pin / Spare Blade Screw Service Kit	(1)
8	48-22-4256	Replacement Cutter Wheels (Set of 2) (Accessory)	(1)