



# Exceeding Expectations



Energy-Efficient AC Pumps

Battery Backup Sump Pumps

Combination Pumps

Sewage Pumps

Innovative Switch Technologies

Water Alarms

Batteries



## Leading the Industry in Green Technology



# Pro Series Pumps

## Company Profile

### Mission Statement

Glentronics, Inc., manufacturer of Pro Series Pumps, is a family-run business and our goal is to take care of every customer just like they are family. Our mission has always been to create proprietary products that provide users with a superior method of accomplishing a task. Through innovation and dedication, we lead the way in battery backup sump pumps, AC sump pumps, sewage pumps and combination pumps. We focus on what we do best.

### History

- Glentronics' owners originally sold batteries to homeowners who used them in backup sump pumps.
- The problem: Homeowners never knew if their battery or backup system was in working condition since the systems didn't alert them when maintenance was needed.
- The Pro Series line was created so professionals could offer their customers "industrial-grade products for the residential market".
- Glentronics introduced a new line of energy-efficient primary pumps, leading the industry in green technology.
- Glentronics came out with the first combination pump system, an AC pump and a backup pump that is pre-assembled to make installation quick and easy.

### Innovation Through Dedication

- Focus on improving our products to benefit our customers, allowing us to create reliable products
- Driven to create unique, industry-leading battery backup and primary sump pumps as well as sewage pumps and accessories
- Continuously ship 100% and on time
- Stock 3–5 months of on-hand inventory to be ready for extreme weather events
- Same-day shipping on all orders, especially emergency orders during storm events
- Continued product-line improvement
- Dedicated to technical support and customer service
  - Free technical support
  - Online support
  - Online installation videos
- Supportive of PR and advertising efforts

### Pro Series Team



## Table of Contents

<b>Company Profile</b>	<b>2</b>
<b>Pro Series Pumps</b>	<b>3</b>
Why Pro Series	
Flyers/Leave-Behinds	
Trainings	
Free Technical Support	
<b>Reliability and Innovation</b>	<b>4</b>
<b>Selection and Quality Guarantee</b>	<b>5</b>
<b>Mix and Match Ordering</b>	<b>6</b>
<b>Sump Pumps</b>	<b>7–9</b>
Pump Construction	7
ST Series	8–9
S2 Series	8–9
S3 Series	8–9
SR Series	9
<b>Chemical Pumps</b>	<b>9</b>
C8 Series	9
<b>Sewage Pumps</b>	<b>10–11</b>
E Series	10–11
<b>Switches and Controllers</b>	<b>12–14</b>
Switches	12
Controllers	13–14
CONNECT Modules	14
<b>Battery Backup Systems</b>	<b>15–19</b>
Why Pro Series Backup	15
Backup Pumps	16–17
Combo Pumps	18–19
Standby Batteries	20
<b>Accessories</b>	<b>21–23</b>
Clenit™ Pit Cleaner	22
Water Alarms	22
Check Valves	23

## Contact Us

### Sales

PHONE: (800) 991-0466, Option 5

FAX: (847) 415-6410

E-MAIL: [Sales@Glentronics.com](mailto:Sales@Glentronics.com)

### Technical Assistance

PHONE: (800) 991-0466, Option 7

FAX: (847) 415-6410

E-MAIL: [Service@Glentronics.com](mailto:Service@Glentronics.com)

*The best technical assistance is over the phone.*

### Corporate Headquarters

645 Heathrow Dr.  
Lincolnshire, IL 60069

### Website

[www.StopFlooding.com](http://www.StopFlooding.com)

# Pro Series Pumps

## Why Pro Series Pumps

Our focus has always been on creating and improving our products to make reliable pumps and other accessories to benefit our customers. That begins by using premium components and designing pumps for maximum pumping capabilities, better energy efficiency, and durability, which is why we lead the industry in green technology. Our patented switches and controllers with state-of-the-art monitoring systems are the result of our innovative engineering.

Pro Series Pumps also excels in helping our customer's maximize their business with the unique Good, Better, Best system, which allows you to offer a range of products to best fit your customers' needs while pumping up your profits. The Mix and Match ordering system provides you with the best options for stocking your inventory and saving on your product investment.

In addition to offering quality products and better ordering options, we back it all up with unmatched support. We provide extended warranties that benefit our professionals, free customized leave-behind sheets, training sessions and lifetime technical support. You also have the ability to be listed as a Pro Series Preferred Installer on our website.

We present you with the means to success!



## Unmatched Support—The Tools for Success

### The Means to Success

Pro Series backup and AC sump pumps offer you more than just the leading pumps in the industry—we support your customers and your sales efforts. Let us share our secrets so we can help you sell more products.

#### Warranties

- Confidence in our products allows us to offer better warranties on our most popular pumps, when installed by a contractor.
- **All** our product warranties begin from the date of installation.

#### FREE Leave-Behind Sheets

- Available for backup, AC pumps and combination pumps to leave with your customers
- Customized with your logo, phone number and website

#### FREE Training Sessions

- For you and your staff to help you sell our products effectively
- Sessions available at your facility or ours

#### FREE Technical Support

- **FREE lifetime technical support** for you and your customers
- If you prefer, have your customers call us for technical support—our customer service team is trained to troubleshoot problems over the phone

#### FREE Listing on Our Distributors' Pages

- Allows contractors to find the closest stocking wholesalers in their area with the distributor's information and website link

#### FREE Listing as Pro Series Preferred Installer

- Sign up to be listed on our website as a Preferred Installer.  
*To be eligible, you must purchase at least four of our systems from your local wholesaler.*





# Reliability and Innovation

## Strong and Dependable Pumps



Designed for higher pumping capacity and increased energy efficiency, resulting in proven reliability.

### Premium Components

- Industrial-grade products, built for the residential market
- Built to run continuously, 24 hours a day, 7 days a week, 365 days a year (ST Series, S3 Series, E7 Series and C8 Series)
- The entire Pro Series AC pump line incorporates:
  - ◆ PSC motors
  - ◆ Thermal protection
  - ◆ Upper and lower sealed ball bearings
  - ◆ Durable pump housing
  - ◆ Harmonically balanced, quiet operation
  - ◆ Double or triple seals to ensure the pump lasts longer

### Better Warranties for Extended Peace of Mind

These upgrades result in powerful pumps that offer superior energy efficiency, durability and longevity. Using industrial-grade components also allow for 1-year, 18-month, 3-year, 4-year and 5-year warranties.

## On the Forefront of Technology

### Patented Dual Float Switch

- Has two floats mounted within a protective cage
- Redundant floats ensure reliable operation

### State-of-the-Art Monitoring

- Featured Pro Series pumps, controllers, backup and combination systems
- Gives your customers security and peace of mind because they know their system is ready to go
  - ◆ 24-hour-a-day monitoring of system and power conditions, and gives visual and audible alerts when problems are detected
  - ◆ Immediately informs the homeowner about problems and required maintenance
  - ◆ USB data port and remote terminal connects to Pro Series Pumps CONNECT Module or other devices to alert homeowners of problems when they are away from home



### Connected Pumps with Remote Notification

- Many of the models in the Pro Series line have a USB data port and remote terminal which allow the pumps to be connected to an external device that can notify a homeowner of a problem or needed maintenance.
- The USB data port and remote terminal can connect to:
  - ◆ Pro Series WiFi Module (PS-WiFi)
  - ◆ Home-security systems or other dry-contact devices
- As technology changes, your Pro Series system with remote notification capabilities can remain current by adding new modules
- Pro Series offers an inexpensive WiFi Module:



**Pro Series CONNECT WiFi Module**  
WiFi-based module will send an email, text message or in-app notification.



**Model PS-WiFi**

Visit [www.stopflooding.com/connected](http://www.stopflooding.com/connected) for more information and updates to our connected devices.

# Selection and Quality Guarantee

## Good, Better, Best Product Selections

The Pro Series line includes a Good, Better, Best option in each product category. We are the only pump company offering this kind of variety in AC pumps, controllers, backup pumps and combination systems.

- Each product has unique features
- Allows you to stock a better selection
- Solutions to meet your customers' needs
- Gives you an opportunity to maximize your business
- Offering a range of products means higher profitability
- Easy to provide a better product for your customer



**ST Series**

Even when a Good pump is selected, you can upgrade to a Better or Best controller.



**DFC1**

Don't forget to suggest a backup pump or combination system!



**PHCC-1000**



**S2 Series**

This system gives your customer the option to upgrade to a Better or Best product.



**DFC1.5**

Use the Good, Better, Best system to help select the products that best fit your customers' needs.



**PHCC-1850**



**S3 Series**



**DFC2**



**PHCC-2400**

\*\*This is just a sampling of our Good, Better, Best product selection; ask your sales representative for more information on additional product lines and the Good, Better, Best options available with those products.

## A Better Warranty

We stand behind our products and those who install them by offering warranties that can be relied on. The premium components in our pumps are what result in dependable and durable pumps, which allows us to offer better warranties that begin from the date of installation.

In a continued effort to support professional installers, we have increased the warranty on our most popular products when purchased and installed by a professional. Extending the warranties not only shows trust in our products but also trust in our professionals and gives your customers peace of mind.

The warranty on all Pro Series switches matches that of the Pro Series pumps when installed new together. Otherwise, a one-year warranty applies when installed separately or on another product. The warranty on all Pro Series batteries is one year from the date of installation, when used with a Pro Series battery backup sump pump system.

System	Contractor Installation	
	Model	Warranty
Battery Backup Pumps	All Backup Systems	3-year
Combination Pumps	PS-C11, PS-C22	3-year
	PS-C33	4-year*
Energy-Efficient Sump Pumps	SR33-VS	18-month
	ST Series	3-year*
	S2 Series	4-year*
	S3 Series	5-year*
Sewage Pumps	All Sewage Pumps	3-year
Chemical Pumps	All Chemical Pumps	1-year
Pump Alternator	All DVSA models	3-year



\* Applicable when purchased and installed by a contractor





# Mix and Match Ordering

## Ordering Sump and Sewage Pumps

### We give you the flexibility to order any pump with any switch!

To provide you with the best options for stocking your inventory, you can order using our Mix and Match method or instead select a pre-packaged pump with a switch included. The Mix and Match ordering system provides you with the best options for stocking your inventory while also saving on your product investment.

#### Option 1: Mix and Match: Order a pump and a switch as separate items.

- Allows you to stock pumps and switches as separate items, then combine and complete the system to meet your customers' needs
- Enables you to stock less inventory, making your product investment lower
- Provides you with the product and tools to upgrade the sale

#### First, order any pump with no switch (NS).

- |                                              |                                   |
|----------------------------------------------|-----------------------------------|
| <input type="checkbox"/> ST1033-NS           | <input type="checkbox"/> E7040-NS |
| <input type="checkbox"/> ST1050-NS           | <input type="checkbox"/> E7055-NS |
| <input type="checkbox"/> S2033-NS            | <input type="checkbox"/> E7105-NS |
| <input type="checkbox"/> S2050-NS            |                                   |
| <input checked="" type="checkbox"/> S3033-NS |                                   |
| <input type="checkbox"/> S3050-NS            |                                   |
| <input type="checkbox"/> S3100-NS            |                                   |

#### Then, order any switch.

- |                                          |                                 |                                 |
|------------------------------------------|---------------------------------|---------------------------------|
| <input type="checkbox"/> DFC1            | <input type="checkbox"/> VS     | <input type="checkbox"/> TS     |
| <input type="checkbox"/> DFC1.5          | <input type="checkbox"/> VSC1.5 | <input type="checkbox"/> TSC1.5 |
| <input checked="" type="checkbox"/> DFC2 | <input type="checkbox"/> VSC2   | <input type="checkbox"/> TSC2   |

S3033 pump with no switch (NS) in the box



S3033-NS

- S3033-NS 1/3 HP - Pump Only  
1-1/2" Discharge - 10' Power Cord
  - S3050-NS 1/2 HP - Pump Only  
2" Discharge - 20' Power Cord
- Float switches and controllers are available

These items will be packaged separately.

DFC2 in the box



#### Option 2: Order as a pre-packaged system, includes pump and switch.

- ◆ Order any pump with switch already packaged in a single carton, ready for delivery.

Order as a complete system with switch already packaged in the box.

To order an S3033 pump with a DFC2, the part number is S3033-DFC2.



#### S3033-DFC2 - 1/3 HP Pump with Deluxe Controller and Dual Float Switch



- Activates pump weekly to exercise and extend pump life
- Monitors pump and power conditions and sounds an alarm when problems are detected
- Designed for sump application



# Sump Pumps

## Premium Components = Quality Pumps

All Pro Series sump pumps use less electricity than competing pumps without sacrificing performance. They feature a high-efficiency Permanent Split Capacitor (PSC) motor, which uses fewer amps than other pumps. Our pumps also offer upper and lower sealed ball bearings, which increase efficiency, durability and allow for quiet operation. These upgrades result in a powerful motor that is efficient, durable and has a long life.

### Premium Components Means GREEN SAVINGS

All Pro Series AC pumps use substantially fewer amps than shaded pole pumps from other manufacturers. That means our pumps are considerably less expensive for a homeowner to operate. Superior energy efficiency translates to lower energy bills for the homeowner.

See [www.StopFlooding.com](http://www.StopFlooding.com) for more details.

## Pump Components and Construction

- 1. Permanent Split Capacitor (PSC) Motor**  
Increases energy efficiency
- 2. Housing:**  
Cast-Aluminum/Nylon Housing (SR Series)  
Cast-Iron/Cast-Aluminum Housing (ST Series)  
Cast-Iron Housing (S2 Series)(E7055)  
Cast-Iron/Stainless-Steel Housing (S3 Series, E7040, E7105)  
Stainless-Steel Housing (C8 Series)
- 3. Strainer:**  
Electroplated Steel Strainer (ST Series)  
Non-corrosive Polypropylene Strainer (SR Series, S3033 and S3050)  
Removable Polycarbonate Strainer (S2 Series)  
Chrome-Plated Steel Strainer (S3100)
- 4. Shaft:**  
Stainless Steel (S3 Series, C8 Series)
- 5. Upper and Lower Sealed Ball Bearings**  
Provide quiet operation that homeowners appreciate
- 6. Water Cooled (no cooling oil)**  
(ST Series, S3 Series, E7 Series and C8 Series)
- 7. Thermally Protected**
- 8. Seals:**  
Two Carbon Ceramic Shaft Seals Plus One Buna-N Seal (ST Series, S3 Series, and E7 Series)  
Carbon Ceramic Shaft Seal Plus One Buna-N Seal (SR Series and S2 Series)  
Silicon Carbide Viton Seals (C8 Series)
- 9. Outlet:**  
1½" outlet (SR33-VS, ST1033, S2033, S2050, S3033)  
2" outlet (ST1050, S3050, S3100, C8050, C8100, E7 Series)
- 10. Impeller:**  
Engineered Polymer (SR Series and ST Series)  
Polycarbonate (S3033 and S3050)  
Cast-Iron Vortex (S2 Series and E7 Series)  
Dynamically Balanced Cast Iron (S3100)  
Stainless Steel (C8 Series)

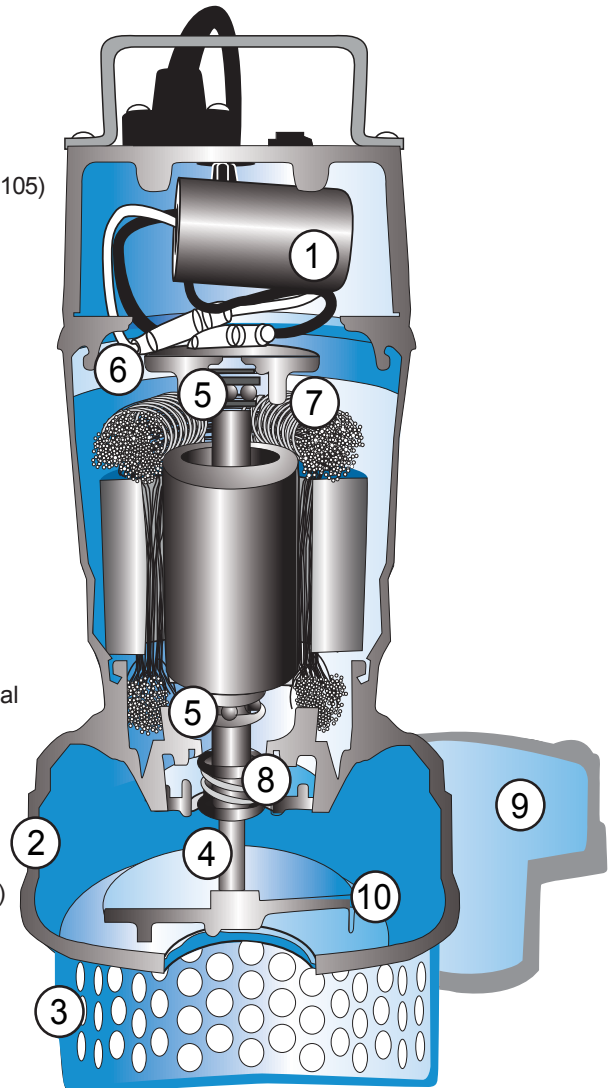



# Sump Pumps



## ST Series Sump Pump

\* 3-year warranty is available when purchased and installed by a contractor; otherwise the original 18-month warranty is applicable.



### Features

- Cast-iron/cast-aluminum construction
- Continuous-duty rated
- Energy-efficient Permanent Split Capacitor (PSC) motor
- Upper and lower ball bearings
- Two Carbon Ceramic Shaft Seals Plus One Buna-N Seal
- Water-cooled motor (no cooling oil)
- Stainless-steel fasteners
- 10-foot pump cord (20-foot option)
- Will fit in 10-inch diameter sump pit
- Includes 2- to 1½-inch PVC reducer (ST1050)

	Model ST1033-NS	Model ST1050-NS
Motor HP	⅓ HP	½ HP
GPM @ 10 Ft	46	72
GPH @ 10 Ft	2770	4320
Max Head	29 ft/8.8 m	32 ft/9.8 m
Discharge	1.5 in/3.8 cm	2 in/5.1 cm
Amps @ 10 Ft	3.8	4.8
Weight	17 lb/7.7 kg	28 lb/12.7 kg
Width	7.5 in/19.1 cm	10 in/25.4 cm
Depth	5 in/12.8 cm	6.5 in/16.5 cm
Height	13.8 in/34.9 cm	16.3 in/41.4 cm

## S2 Series Sump/Effluent Pump

\* 4-year warranty is available when purchased and installed by a contractor; otherwise the original 3-year warranty is applicable.



### Features

- Cast-iron construction
- Energy-efficient Permanent Split Capacitor (PSC) motor
- Cast-iron vortex impeller
- Upper and lower ball bearings
- Carbon ceramic plus Buna N shaft seals
- Thermally protected
- Stainless-steel fasteners
- Pumps solids up to ½ inch
- Removable strainer
- 10-foot pump cord (20-foot option)

	Model S2033-NS	Model S2050-NS
Motor HP	⅓ HP	½ HP
GPM @ 10 Ft	53	64
GPH @ 10 Ft	3200	3840
Max Head	23 ft/7 m	26 ft/8 m
Discharge	1.5 in/3.8 cm	1.5 in/3.8 cm
Amps @ 10 Ft	5	5.5
Weight	21.1 lb/9.6 kg	22.1 lb/10.0 kg
Width	9 in/22.9 cm	9 in/22.9 cm
Depth	6.5 in/16.5 cm	6.5 in/16.5 cm
Height	11.75 in/29.8 cm	11.75 in/29.8 cm

## S3 Series Sump Pump

\* 5-year warranty is available when purchased and installed by a contractor; otherwise the original 3-year warranty is applicable.



### Features

- Cast-iron/stainless-steel construction
- Continuous-duty rated
- Energy-efficient Permanent Split Capacitor (PSC) motor
- Upper and lower ball bearings
- Two Carbon Ceramic Shaft Seals Plus One Buna-N Seal
- Water-cooled motor (no cooling oil)
- Stainless-steel fasteners
- 20-foot pump cord (S3050 & S3100), 10-foot pump cord (S3033–20-foot option available)
- Includes 2-inch to 1½-inch PVC reducer (S3050)

	Model S3033-NS	Model S3050-NS	Model S3100-NS
Motor HP	⅓ HP	½ HP	1 HP
GPM @ 10 Ft	50	65	92
GPH @ 10 Ft	3000	3900	5520
Max Head	30 ft/9.1 m	33 ft/10.0 m	52 ft/15.8 m
Discharge	1.5 in/3.8 cm	2 in/5.1 cm	2 in/5.1 cm
Amps @ 10 Ft	4.0	4.3	11.5
Weight	20 lb/9.1 kg	24 lb/10.9 kg	46 lb/20.9 kg
Width	7.9 in/20.1 cm	8.5 in/21.6 cm	11.0 in/27.9 cm
Depth	5.3 in/13.5 cm	6.3 in/16.0 cm	7.7 in/19.5 cm
Height	13.0 in/33.0 cm	13.4 in/34.0 cm	18 in/45.7 cm



# Sump and Chemical Pumps



## SR Series Sump Pump



### Features

- Cast-aluminum body/durable nylon cover with polypropylene volute
- Energy-efficient Permanent Split Capacitor (PSC) motor
- Upper and lower sealed ball bearings
- Carbon ceramic plus Buna N shaft seals
- Stainless-steel fasteners
- Built-in vertical switch
- 10-foot pump cord
- Will fit in 10-inch diameter sump pit

### Model SR33-VS

Motor HP	1/3 HP
GPM @ 10 Ft	47
GPH @ 10 Ft	2820
Max Head	24.6 ft/7.5 m
Discharge	1.5 in/3.8 cm
Amps @ 10 Ft	3.3
Weight	12.2 lb/5.5 kg
Width	8 in/20.3 cm
Depth	6 in/15.2 cm
Height	12.5 in/31.8 cm

### Flow Chart

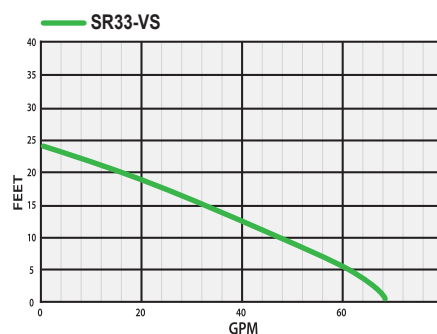

### Flow Chart

— ST1033 — ST1050

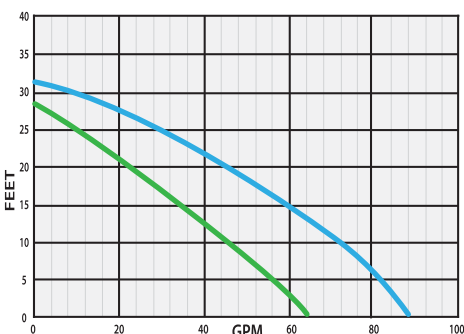

### Flow Chart

— S2033 — S2050

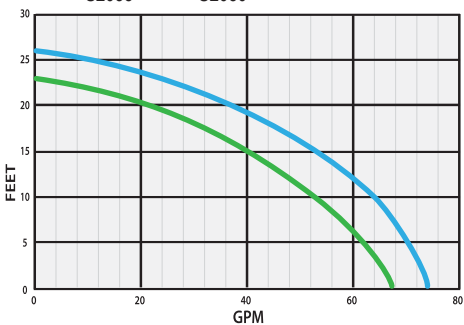

### Flow Chart

— S3033 — S3050 — S3100

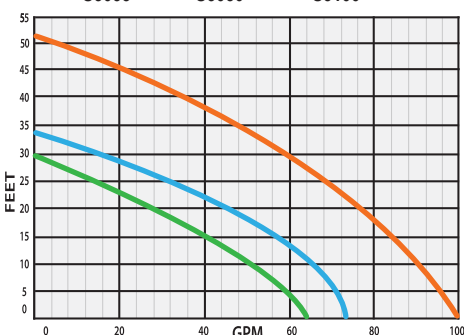

## C8 Series Chemical Pump



### Features

- All 304 stainless-steel construction
- Intended for pumping non-flammable fluids compatible with pump component materials
- Energy-efficient Permanent Split Capacitor (PSC) motor
- Upper and lower sealed ball bearings
- Dual carbon/ceramic/Viton seals
- Continuous-duty rated
- Liquid cooled

### C8050-NS C8100-NS

Motor HP	1/2 HP	1 HP
GPM @ 10 Ft	64	82
GPH @ 10 Ft	3840	4920
Max Head	36 ft/11 m	49 ft/14.9 m
Discharge	2 in/5.1 cm	2 in/5.1 cm
Amps @ 10 Ft	4.7	11.3
Weight	23 lb/10.4 kg	46 lb/20.9 kg
Width	9.1 in/23.1 cm	10.4 in/26.4 cm
Depth	6.3 in/16 cm	7.5 in/19.1 cm
Height	16.3 in/41.4 cm	18.1 in/46 cm

### Flow Chart

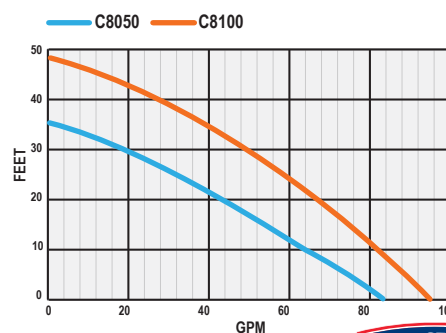



# Sewage Pumps



## E7040—4/10 HP



### Features

- Cast-iron/stainless-steel construction
- Energy-efficient Permanent split capacitor (PSC) motor
- Handles 2-inch solids with 2-inch discharge
- Continuous-duty rated
- Water-cooled motor (no cooling oil)
- Electroplated steel shaft
- Stainless-steel fasteners
- Dual carbon/ceramic shaft seals plus Buna N seal
- Upper and lower sealed ball bearings
- 10-foot power cord (20-foot option available)

### Model E7040-NS/ EBIS40V

Motor HP	4/10 HP
GPM @ 10 Ft	74
GPH @ 10 Ft	4440
Max Head	22 ft/6.7 m
Max Diameter Solids	2 in/5.1 cm
Discharge	2 in NPT/5.1 cm
Amps @ 10 Ft	6.3
Weight	36 lb/16.3 kg
Width	9 in/22.9 cm
Depth	5.875 in/15 cm
Height	19 in/48.3 cm

## E7055—1/2 HP



### Features

- Cast-iron construction
- Energy-efficient Permanent Split Capacitor (PSC) motor
- Handles 2-inch solids with 2-inch discharge
- Continuous-duty rated
- Water-cooled motor (no cooling oil)
- Electroplated steel shaft
- Stainless-steel fasteners
- Dual carbon/ceramic shaft seals plus Buna N seal
- Upper and lower sealed ball bearings
- 10-foot power cord

### Model E7055-NS

Motor HP	1/2 HP
GPM @ 10 Ft	89
GPH @ 10 Ft	5340
Max Head	23 ft/7.0 m
Max Diameter Solids	2 in/5.1 cm
Discharge	2 in NPT/5.1 cm
Amps @ 10 Ft	7.0
Weight	37 lb/16.8 kg
Width	9 in/22.9 cm
Depth	5.875 in/15 cm
Height	16.5 in/42.3 cm



## E7105—1 HP



### Features

- Cast-iron/stainless-steel construction
- Energy-efficient Permanent Split Capacitor (PSC) motor
- Handles 2-inch solids with 2-inch discharge
- Continuous-duty rated
- Water-cooled motor (no cooling oil)
- Electroplated steel shaft
- Stainless-steel fasteners
- Dual carbon/ceramic shaft seals plus Buna N seal
- Upper and lower sealed ball bearings
- 10-foot power cord (20-foot option available)

### Model E7105-NS

Motor HP	1 HP
GPM @ 10 Ft	100
GPH @ 10 Ft	6000
Max Head	32 ft/9.75 m
Max Diameter Solids	2 in/5.1 cm
Discharge	2 in NPT /5.1 cm
Amps @ 10 Ft	10.5
Weight	41.1 lb/8.6 kg
Width	9 in/22.9 cm
Depth	5.875 in/15 cm
Height	20 in/50.8 cm



# Sewage Pumps

## EBIS40V—4/10 HP

### Flow Chart

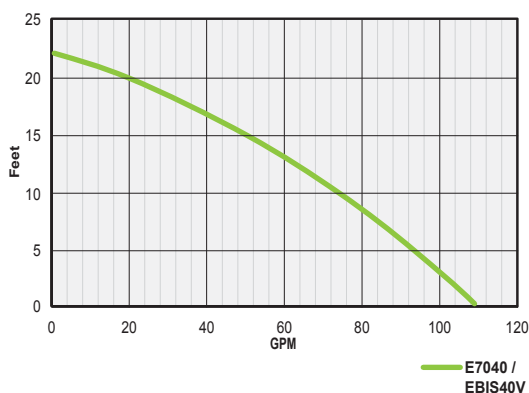

### Features

- Cast-iron/stainless-steel construction
- Reliable, built-in vertical switch
- Energy-efficient Permanent Split Capacitor (PSC) motor
- Handles 2-inch solids with 2-inch discharge
- Continuous-duty rated
- Water-cooled motor (no cooling oil)
- Electroplated steel shaft
- Stainless-steel fasteners
- Dual carbon/ceramic shaft seals plus Buna-N seal
- Upper and lower sealed ball bearings
- 10-foot power cord (20-foot option available)



## Pre-Assembled Sewage Pit

### Packaged Systems

The Pro Series Pumps pre-packaged sewage pit comes pre-assembled for easy installation. Select the size pump needed, the style of float, and pick the controller with the level of features wanted.

- Energy-efficient sewage pump in  $\frac{1}{10}$ ,  $\frac{1}{2}$ , and 1 HP
- Pump rests in a formed mold, which prevents torquing
- 6 float-switch options

### Includes

- Sewage pump and switch
- 18- x 30-inch sewage pit with rubber inlet
- Lid with flanges, inspection panel and cord seal
- All gaskets and stainless-steel hardware
- 2-inch discharge piping from the pump to the lid
- PS-WS\* included with VSC2/TSC2

\*Meets codes enacted by some states where an alarm is required to alert of high water in a residential sewage pit



EP Series

### Water Sensor

#### Model PS-WS

- For use in sump or sewage pits
- When water reaches the Water Sensor:
  - Paired with the Deluxe Controller (DFC2, VSC2 and TSC2), will activate a warning light, an audible alarm, and send a signal to the remote terminal
  - Paired with the Water Alarm (PWA2), will sound an audible 110 db alarm
- Attaches to discharge pipe
- Mounting hardware included
- 10-foot cord with 3.5mm plug



### Flow Chart

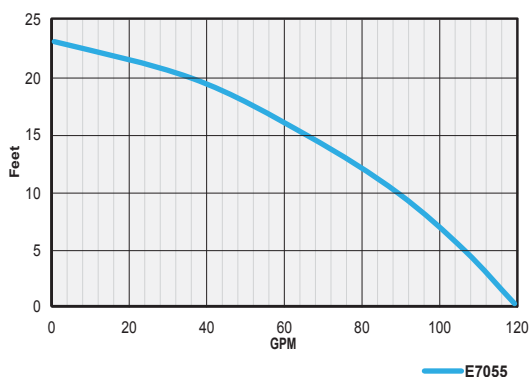

### Flow Chart

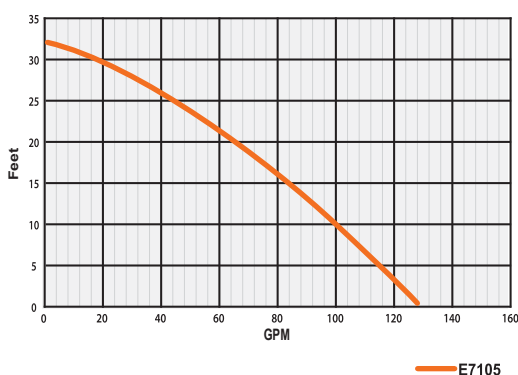



# Switches and Controllers

## TS—Tether Switch

Model TS



Model TSC1.5



Model TSC2/TSC3



Piggy-back plug version (Model TS)

Tether switch for Enhanced and Deluxe controllers



### Features

- Can be used in clear water and sewage applications
- Two versions of the tether switch:
  - **Piggy-back plug (120 VAC) version—no controller (TS)**
    - Wide angle in order to increase run time
    - Activates pump at about +45° and turn off at about -45°
  - **Tether switch with controller**
    - Available with Enhanced, Deluxe and Ultimate controllers
    - Narrow angle in order to reduce run time
    - Adjustable run time
    - Activates pump at about +15° and turn off at about -15°
    - Detachable float switch allows the wire to feed through the pit cover for easy installation and maintenance
- Mounts to discharge pipe with included stainless-steel hose clamp
- Adjustable activation level
- 20-foot cord option available (Model-20)

## VS—Vertical Switch

Model VSC1.5



Model VSC2/VSC3



Piggy-back plug version (Model VS)



### Features

- Can be used in clear water and sewage applications
- Two versions of the vertical switch:
  - **Piggy-back plug (120 VAC) version—no controller (VS)**
    - 10-foot power cord
  - **Vertical switch for controllers**
    - Available with Enhanced, Deluxe and Ultimate controllers
    - Internal switching mechanism has sealed gold contacts for reliable high-cycle operation
    - Detachable float switch allows the wire to feed through the pit cover for easy installation and maintenance
- Mounts to discharge pipe with included stainless-steel hose clamp
- Adjustable activation level
- 20-foot cord option available (Model-20)

## DF—Dual Float Switch

Model DFC1



Model DFC1.5



Model DFC2/DFC3



### Features

- Available with the Standard, Enhanced, Deluxe and Ultimate controllers
- Two micro-reed-activated floats for added reliability
- Protective cage prevents debris from interfering with floats
- Easy installation
- Solid top keeps out sand and dirt
- Vented, curved bottom prevents debris build-up under the float
- Detachable float switch allows the wire to feed through the pit cover for easy installation and maintenance (Model DFC1.5/DFC2)
- Mounts to discharge pipe with included stainless-steel hose clamp
- Adjustable activation level
- 20-foot cord option available (Model-20)

# Switches and Controllers

## Controller Features

### Standard Controller and Dual Float Switch (Model DFC1)

- Two micro-reed-activated floats for added reliability
- Protective cage prevents debris from interfering with floats
- Switch is mounted independently, allowing user to adjust the height of pump activation

### Enhanced Controller

- Available with a Dual Float (DFC1.5), Vertical Switch (VSC1.5) or Tether Switch (TSC1.5)
- Activates pump weekly to exercise and extend pump life
- Pump run time is adjustable

### Deluxe and Ultimate Controller

- Available with a Dual Float (DFC2), Vertical Switch (VSC2) or Tether Switch (TSC2)
- Monitors pump and power conditions and sounds an alarm when problems are detected
- Visual/audible notification and recommended maintenance remedy
- Activates pump weekly to exercise and extend pump life
- Pump run time is adjustable
- USB data port and remote terminal connect to external devices such as the Pro Series Pumps CONNECT WiFi module, or other devices for remote notification
- 3.5 mm accessory jack allows you to add a High-Water Accessory or 360° Water Sensor (**Deluxe Controller only**)

## Controller Comparison

	<b>Standard</b> DFC1	<b>Enhanced</b> DFC1.5, VSC1.5 TSC1.5	<b>Deluxe</b> DFC2, VSC2 TSC2	<b>Ultimate</b> DFC3, VSC3 TSC3
Available with Dual Float Switch	•	•	•	•
Available with Vertical Switch		•	•	•
Available with Tether Switch		•	•	•
Sounds an alarm and alerts when:				
AC power has failed			•	•
Pump or float problem is detected			•	•
9V battery is low or slide switch is off			•	•
Remote Notification Connections:				
USB data port (ability to remotely notify which alert has activated or what maintenance might be needed)			•	•
Remote terminal (ability to remotely notify of a problem or needed maintenance)			•	•
Float switch can be unplugged from controller for easy installation		•	•	•
System operating light (flashes)		•	•	•
Adjustable run time from 5–45 seconds after the water falls		•	•	•
Activates pump weekly to exercise and extend pump life		•	•	•
3.5mm accessory jack			•	
Utilizes solid-state circuitry for high cycling				•
Universal controller mounting tabs		•	•	•
2-foot power cord		•		
4-foot power cord			•	•
10-foot float-switch cord	•	•	•	•
Piggy-back plug	•	•	•	•

## Standard

Model  
DFC1

### Standard Controller with Dual Float



Patented

## Enhanced

Model  
TSC1.5  
VSC1.5  
DFC1.5

### Enhanced Controller



Patented

## Deluxe



Model  
TSC2  
VSC2  
DFC2

### Deluxe Controller

Optional  
Accessories



Patented

## Ultimate



Model  
TSC3  
VSC3  
DFC3

### Ultimate Controller

Ideal for  
high-cycle  
applications



Patented





# Switches and Controllers

## Pump Alternator Control and Alarm System



### Features

- Prolongs pump life by alternating two primary pumps
- If one pump fails, the other pump will take over and an alarm will sound
- Flashing light will indicate which pump is failing
- Remote terminal allows the unit to connect to the Pro Series WiFi Module, security system or other dry-contact-based device
- If one float switch fails, the other float switch will take over and an audible alarm will sound
- Detachable float-switch wires for easy installation
- Angled receptacles to accept standard or right-angled pump plugs
- High Water Alarm with accompanying LED indicator, audible alarm, and 9V battery backup



### Switch Options

Model DVSA-DF

Model DVSA-VS



### Single Activation Pump Alternator Model DVSA

- Runs one pump at a time
- Can handle up to 1 HP pumps (max 15 amps each pump)

### Dual Activation Pump Alternator Model DVSA-DF / DVSA-VS

- Can run **both** pumps at the same time for extra capacity (total 15 amps)
- **Includes your choice of either:**
  - Two low-voltage vertical float switches (Model DVSA-VS)
  - Two caged dual float switches (Model DVSA-DF)
- Built-in circuit breakers for both pumps (15 total amps max)

## Remote Notification

Are you afraid to leave the house during a storm, not knowing if you will come back to a flooded basement? The Pro Series Pumps CONNECT line of pumps has the ability to alert you via text, email, or in-app notification to a problem in the pit or if maintenance is needed. This is possible because The CONNECT line of products comes with built-in gateways, allowing the user to easily link their pump system to a wi-fi network, home security system or other dry-contact-based device.

You can feel safe that Pro Series is **pumping for you.**

### Remote Notification Compatibility:

**Primary Pump Switch:**  
DFC2, VSC2, TSC2,  
DFC3, VSC3, TSC3, DVSA

**Backup Systems:**  
PHCC 1850, PHCC 2400

**Combo Systems:** PS-C22, PS-C33



### Pro Series Pumps CONNECT Module

#### Pro Series WiFi Module

- Sends emails, texts, or in-app notifications to your phone, tablet or computer
- FREE Apple and Android app available
- **No monthly fee**
- Simple setup



Model PS-WiFi

#### High Water Float

- Optional add-on for use with WiFi Module that allows the PS-WiFi to be used as a free-standing Wi-Fi water alarm
- Sends an alert by text or e-mail when the water reaches the high-water float
- Detect water as low as 3/8 inch.



Model HWF

Visit [www.StopFlooding.com/connected](http://www.StopFlooding.com/connected) for more information and updates to our connected devices.

# Battery Backup Sump Pumps

## Why Do You Need a Backup Sump Pump System?

### If the power goes out, your main AC pump will not run and your basement will flood.

The Pro Series backup system will pump intermittently for days, providing a secondary pumping source. For increased run time, the larger backup models can handle extra batteries for extended pumping time.

### If your main pump fails due to a mechanical problem, or if the pump is clogged with debris, the basement will flood.

The Pro Series system will provide a secondary pump and keep your basement dry.

### If the float switch on your main pump gets stuck or fails, your basement will flood.

The Pro Series backup system will activate, pump the water out, and sound an alarm that the main pump did not activate.

### If the discharge pipe in your main pump is clogged or frozen, or if the sewer is full, your basement will flood.

The Pro Series system will provide a secondary discharge line when you plumb it directly outside. The water will have somewhere to go other than your basement.



## Why Pro Series Backup and Combination Systems

### Proven Reliability

- Decades preventing basements from flooding
- Features the most complete monitoring alarm system and high-capacity pumps
- Designed to be a major appliance with years of dependable service
- 100% factory tested

### Redundancy

- Dual float switches on all backup systems provide twice the protection
- Combination systems have four total float switches to ensure the pumps run when needed
- Backup pumps can be installed separately or combined with a "Y" connector to meet any installation requirement

### Monitoring Features

- Exclusive monitoring and alarm features provide security and peace of mind for homeowners and contractors
- User-friendly audible and visual alarms notify the user that maintenance is needed, ensuring operation when needed

### Pro Series Pumps CONNECT

- Remote notification available using built-in USB data port or remote terminal (Model PHCC-1850, PHCC-2400, PS-C22 & PS-C33) allowing for emergency or maintenance alerts via text, email, in-app notification, home security system, or other dry-contact device

### Good, Better, Best Selection

- Gives users and contractors a choice that satisfies every feature or budget requirement





# Battery Backup Sump Pumps



## PHCC-1000



## Features

### Pro Series backup sump pumps protect against:

- Power outages • Primary pump failures • Float switch failures • Excessive inflow of water

### Pro Series backup sump pumps sound an alarm when:

- AC power is out, or the circuit breaker has blown
- Battery fluid is low and water needs to be added
- Battery is discharged or terminals need cleaning
- Pump was activated



### Pro Series backup sump pumps offer:

- 12-volt DC sump pump with decades of proven reliability
- 24-hour-a-day monitoring of battery, pump conditions and battery fluid level
- Socketed dual float switches for added reliability and ease of installation
- USB data port and remote terminals connect to external devices such as Pro Series Pumps CONNECT WiFi Module or other devices for remote notification (Model PHCC-1850, PHCC-2400)
- OPTIONAL 20-foot cord available for backup pump, controller and float switches
- Compatible with wet-cell or AGM/maintenance-free batteries



## PHCC-1850



## PHCC-2400



### Backup System Comparison

	PHCC-1000	PHCC-1850	PHCC-2400
Pumping capacity (in gallons per hour @ 10-foot height)	1000 GPH	1850 GPH	2400 GPH

#### EFFICIENT

Charger strength (the higher the amps, the faster it will recharge the battery)	.4 amps	1.6 amps	13 amps
Caged dual float switch provides added protection			•
System pumps intermittently for days	•	•	•

#### AUTOMATIC

Switches automatically to battery power when AC power fails	•	•	•
Pumps automatically when water volume exceeds the capacity of the main AC pump	•	•	•
Automatically tests the pump weekly		•	•
Alarms when pump is clogged			•

#### VERSATILE

Pumps on AC power when available as well as battery power			•
Designed for use with wet-cell or maintenance-free batteries	•	•	•
Can accommodate multiple standby batteries to extend the run time		•	•
USB data port (ability to remotely notify which alert has activated or what specific maintenance might be needed)		•	•
Remote terminal (ability to remotely notify of a problem or needed maintenance)		•	•

#### USER-FRIENDLY

Detects irregularities, sounds an alarm, and pinpoints problems and solutions on the control panel	•	•	•
Alarm can be silenced during a power outage	•	•	•



# Battery Backup Sump Pumps

## Specifications

	Model PHCC-1000	Model PHCC-1850	Model PHCC-2400
Flow @ 10-Ft GPH (3 M) Head	1,000 GPH	1,850 GPH	2,400 GPH
Amps @ 10-Ft Total Head	6.5 amps	10–12 amps	20 amps
Outlet	1.5 in PVC adapter	1.5 in PVC adapter	1.5 in PVC adapter
Voltage	12 VDC	12 VDC	12 VDC
Power Input	115VAC, 60 Hz	115VAC, 60 Hz	115VAC, 60 Hz
Charger Strength Voltage/Current	12 VDC/4 amps	12 VDC/1.6 amps	12 VDC/13 amps
Motor Type	DC	DC	DC

## Construction

Pump Housing	Non-corrosive ABS	Non-corrosive ABS	Non-corrosive ABS
Impeller	Non-corrosive ABS	Non-corrosive ABS	Fiber-filled polycarbonate
Shaft Material	Stainless steel	Stainless steel	Stainless steel
Float Switch	Dual micro-reed switches	Dual micro-reed switches	Caged dual micro-reed switches
Pump Dimensions (WxDxH)	8.5 x 4.5 x 6.5 in (21.6 x 11.4 x 16.5 cm)	9.0 x 5.0 x 7.5 in (22.9 x 12.7 x 19.1 cm)	9.0 x 4.5 x 8.5 in (22.9 x 11.4 x 21.6 cm)
Controller Dimensions (WxDxH)	4.0 x 2.5 x 4.5 in (10.2 x 6.4 x 11.4 cm)	7.0 x 3.0 x 4.4" in (17.8 x 7.6 x 11.1 cm)	6.25 x 7.25 x 8.25 in (15.9 x 18.4 x 20.9 cm)
Shipping Weight	9.0 lb (4.1 kg)	12.0 lb (5.4 kg)	23.0 lb (10.4 kg)

## Pumping Time with Battery\*

B-1000	50 hours	Not recommended	Not recommended
B-2200	100 hours	60 hours	50 hours
(2) B-2200	Not recommended	120 hours	100 hours
B12-100	110 hours	70 hours	55 hours
(2) B12-100	Not recommended	140 hours	110 hours

\* Run time based on 10% duty cycle. Run times may vary based on water flow.

## Flow Chart

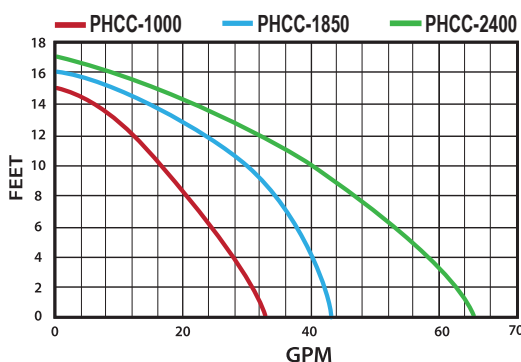

## Included with System

- 12 VDC sump pump
- Control unit with fluid sensor
- Caged dual float switch (Model PHCC-2400)
- Dual float switch (Model PHCC-1000/1850)
- Snap-on non-corrosive screen
- 1½-inch pipe adapter
- Battery cap that accommodates fluid sensor
- Battery box

## Installation

### Direct discharge outside

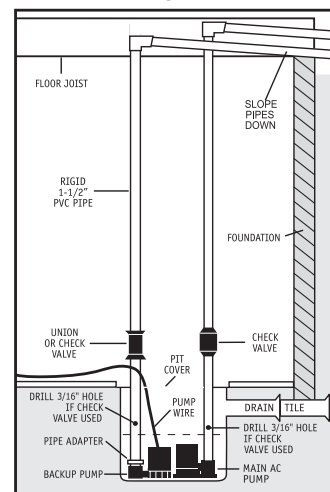

### Discharge into existing pipe

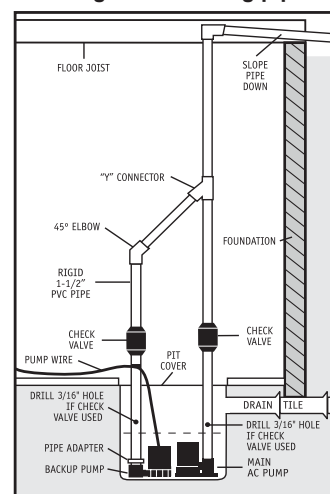

### Installation in narrow sump pit

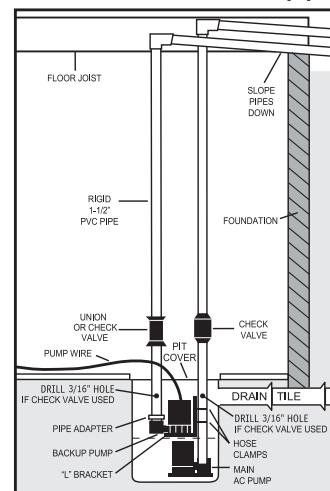



# Combination Systems

## PS-C11



### Key Features

- **ST1033 Primary**—Pumps 2770 GPH at 10 feet
- **PHCC-1000 Backup**—Pumps 1000 GPH at 10 feet
- **The new design of the combination systems:**
  - Allows for installation in smaller pits and for easy adjustment of the floats
  - Lowers the height of the “Y” to accommodate shorter pits
  - Mounted both float switches to the float-stick, a 3/4-inch pipe that is included in the box
- Designed for use with wet-cell or maintenance-free batteries
- Socketed dual float switches for added reliability and ease of installation
- Unique 24-hour-a-day monitoring controller sounds an alarm if maintenance is needed
- OPTIONAL 20-foot cord available for backup pump, controller and float switches



## PS-C22



### Key Features

- **ST1033 Primary**—Pumps 2770 GPH at 10 feet
- **PHCC-1850 Backup**—Pumps 1850 GPH at 10 feet
- **The new design of the combination systems:**
  - Allows for installation in smaller pits and for easy adjustment of the floats
  - Lowers the height of the “Y” to accommodate shorter pits
  - Mounted both float switches to the float-stick, a 3/4-inch pipe that is included in the box
- Designed for use with wet-cell or maintenance-free batteries
- Can accommodate two standby batteries to double the run time
- Socketed dual float switches for added reliability and ease of installation
- Unique 24-hour-a-day monitoring controller sounds an alarm if maintenance is needed and runs pump weekly to test for proper operation
- USB data port and remote terminals connects to external devices such as Pro Series Pumps CONNECT Modules, home automation systems, and other devices for remote notification
- OPTIONAL 20-foot cord available for backup pump, controller and float switches



## PS-C33

\* 4-year warranty is available when purchased and installed by a contractor; otherwise the original 3-year warranty is applicable.



### Key Features

- **S3033 Primary**—Pumps 3000 GPH at 10 feet
- **PHCC-2400 Backup**—Pumps 2400 GPH at 10 feet
- **The new design of the combination systems:**
  - Allows for installation in smaller pits and for easy adjustment of the floats
  - Lowers the height of the “Y” to accommodate shorter pits
  - Mounted both float switches to the float-stick, a 3/4-inch pipe that is included in the box
- Designed for use with wet-cell or maintenance-free batteries
- Can accommodate two standby batteries to double the run time
- Socketed caged dual float switches for added reliability and ease of installation
- Unique 24-hour-a-day monitoring controller sounds an alarm if maintenance is needed and runs pump weekly to test for proper operation
- USB data port and remote terminals connects to external devices such as Pro Series Pumps CONNECT Modules, home automation systems, and other devices for remote notification
- OPTIONAL 20-foot cord available for backup pump, controller and float switches

# Combination Systems

## Features

### All Pro Series combination systems feature:

- Pre-assembled for quick and easy installation
- Compact footprint fits neatly into most sump pits
- Automatically switches to battery power when AC fails
- Unique monitoring controller detects irregularities, sounds an alarm, and pinpoints problems and solutions on control panel
- Primary pump with energy-efficient PSC motor is continuous-duty rated and water cooled
- Primary pump controller allows for adjustable pump run time and exercises pump weekly to extend pump life
- Dual float switches provide dependable activation for both primary and backup pumps
- Backup will assist primary pump if excessive amounts of water are entering the sump pit
- Maintains and recharges battery automatically
- Alarm can be silenced during a power outage
- Designed for use with wet-cell or maintenance-free batteries
- Pumps are securely attached to raised sump foot with stainless-steel screws to prevent movement or breakage

## Backup Pump Monitoring

Will sound alarm indicating:	PS-C11	PS-C22	PS-C33
Battery needs water	●	●	●
Battery is old and needs to be replaced	●	●	●
Battery is discharged	●	●	●
Cable is loose or terminals are corroded	●	●	●
Power, fuse or circuit breaker has failed	●	●	●
Pump has been activated; check the main pump for failure	●	●	●
Remote notification ability		●	●
Automatically tests pump weekly		●	●
Backup pump runs off AC power as well as battery power			●
Displays percentage of power remaining in the battery			●

## Included with System

- Pre-assembled:
  - Primary pump
  - Backup pump
  - (3) 1½" standard no-hub couplings
  - (2) Standard check valves with hardware
  - Sump foot—raises and secures both pumps
- Backup system controller/charger with fluid sensor
- Primary pump with enhanced controller and caged dual float switch (Model DFC1.5)
- Battery box

## Specifications

Primary Pump	Model PS-C11	Model PS-C22	Model PS-C33
Flow at 10 Ft Head	2770 GPH	2770 GPH	3000 GPH
Max Head	29 ft/8.8 m	29 ft/8.8 m	30 ft/9.1 m
Discharge	1½ in	1½ in	1½ in
Motor HP	⅓	⅓	⅓
Voltage	115V, 60Hz	115V, 60Hz	115V, 60Hz
Amp draw at 10 Ft	3.8	3.8	4.0

Backup Pump	PS-C11	PS-C22	PS-C33
Flow at 10 Ft Head	1000 GPH	1850 GPH	2400 GPH
Voltage	12 VDC	12 VDC	12 VDC
DC Current	6.5 amps	10–12 amps	20 amps

Dimensions	PS-C11	PS-C22	PS-C33
Width	8.9 in/22.6 cm	8.9 in/22.6 cm	10.0 in/25.4 cm
Depth	11.0 in/27.9 cm	11.0 in/27.9 cm	11.0 in/27.9 cm
Height	26.8 in/60.2 cm	26.8 in/60.2 cm	28.8 in/60.2 cm
Weight	28.5 lb/12.9 kg	32 lb/14.5 kg	43 lb/19.5 kg

## Pump Construction

### Primary Pump

- Permanent Split Capacitor (PSC) motor
- Upper and lower sealed ball bearings
- Cast-iron/cast-aluminum housing (Model PS-C11, PS-C22)  
Cast-iron/stainless-steel housing (Model PS-C33)
- Electroplated steel shaft (Model PS-C11, PS-C22)  
Stainless-steel shaft (Model PS-C33)
- Dual carbon ceramic shaft seals plus additional Buna N seal
- Engineered polymer impeller (Model PS-C11, PS-C22)  
Polycarbonate impeller (Model PS-C33)
- Stainless-steel fasteners

### Backup Pump

- Non-corrosive ABS housing
- Stainless-steel shaft and fasteners
- Rulon seal (Model PS-C11, PS-C22)  
Carbon ceramic seal w/ Buna N seal (Model PS-C33)
- Non-corrosive ABS impeller (Model PS-C11, PS-C22)  
Non-corrosive fiber-filled impeller (Model PS-C33)
- Dual ball bearings (Model PS-C33)



# Standby Batteries

## Why use a Pro Series Standby Battery?

### Pro Series Standby Batteries are designed to

- Run the pump longer...for more hours per charge
- Last longer in standby operation
- Work with all backup and combination systems
- Accommodate the battery fluid sensor (wet-cell batteries)
- \* Acid sold separately (wet-cell batteries)

### Types of Batteries

#### Maintenance-Free/AGM Standby Battery

- Provide dependable service without having to add distilled water

#### Wet-Cell Standby Batteries

- Shipped dry without battery fluid, giving you peace of mind that the battery is 100% ready to go once it is activated with the fluid

Pumping Time	Maintenance-Free Battery		Wet-Cell Batteries		
System	Model B12-100	(2) B12-100 with PJC	Model B-2200	(2) B-2200 with PJC	Model B-1000
PHCC-1000	110 hours*	Not recommended	100 hours*	Not recommended	50 hours*
PHCC-1850	70 hours*	140 hours*	60 hours*	120 hours*	Not recommended
PHCC-2400	55 hours*	110 hours*	50 hours*	100 hours*	Not recommended

\*Based on 10% duty cycle. Run times may vary based on inflow of water.

Specifications	Maintenance-Free Battery	Wet-Cell Batteries	
	B12-100	B-2200	B-1000
Height (Top of Post)	9 $\frac{3}{8}$ in	10 in	9 $\frac{1}{4}$ in
Length	12 in	12 $\frac{7}{8}$ in	11 $\frac{1}{8}$ in
Width	6 $\frac{1}{2}$ in	6 $\frac{5}{8}$ in	6 $\frac{1}{2}$ in
Voltage	12 VDC	12 VDC	12 VDC
Shipping Weight	57 lb	37 lb	20.5 lb
Case Size	31	31	24
	100 amp hours	31	Reserve capacity @ 25 amps



### Battery Accessories

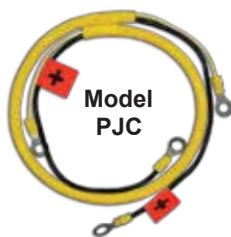

#### Parallel Jumper Cables

- Parallel Jumper Cables extend the run time of the PHCC-1850 and PHCC-2400 battery backups and the PS-C22 and PS-C33 combination systems
- Connects multiple Pro Series batteries
- 12-gauge wires, 40-inch length with  $\frac{3}{16}$ -inch and  $\frac{5}{16}$ -inch ring terminals



#### 6 Qt. Battery Fluid

- Activates wet-cell battery only
- Flexible pour spout

Model Z-Pack

# Accessories

## Sump Foot

### 2 Styles Available

#### Key Features

- Pre-drilled holes for ease of installation
- Made of high-impact polypropylene
- Keeps pumps out of dirt and debris
- Includes mounting hardware
- 1-year warranty

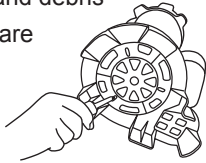

#### Sump Foot for 1 Pump

##### Model SF1A

- Provides solid base for a single pump, either backup or primary pump



#### Sump Foot for 2 Pumps

##### Model SF2A

- Provides solid base for both backup and primary pump



## Cord Management Box

### Minimize Your Tangled Mess of Cords!

#### Model PS-MB994

- Indoor and outdoor use
- Great way to identify “installed by” and “model”
- Cord gasket and mounting hardware included
- Door can open 180°
- Built-in latch keeps enclosure closed
- Flexible mounting options



## Clenit™ Cleans It!

### Clenit™ does the work so you don't have to!

- Removes iron ochre, the red slime buildup, from your sump pit
- Helps maintain a healthy pump and pit
- Great for periodic pit maintenance

Simply pour Clenit™ into your sump system, allow the proprietary powder to attack the iron ochre, and have your pump evacuate the pit. Since Clenit™ is made from a naturally occurring compound, it is 100% biodegradable and safe for the environment.

**Clenit™**  
CLEANSES IRON OCHRE IN SUMP PITS

Model CL7





# Water Alarms

## Water Alarm and Optional Accessories

### Accidents happen...

**Model PWA2**

Place a water alarm wherever there is a risk of water damage:

- Washing machines overflow
- Water heaters leak
- Laundry tubs clog and spill over
- Water pipes break

### Dependable protection

- Solid-state circuitry is extremely sensitive and reliable
- 110 dB alarm can be heard throughout the house

### Extended life

- Alarm will sound up to 3 days
- Up to 5 years of protection on a new alkaline battery (dependent on the shelf life of the battery)

### Easy to use

- Install a 9V alkaline battery (not included) and place the alarm on the floor, or hang the alarm and extend the sensor to the floor or into the sump pit



Standalone Water Alarm has built-in accessory jack for optional, add-on accessories



**Model PWA2**

### Available Add-on Accessories:



#### 20-Foot Extension

**Model EXT-PWA20**

- For use with 360° Water Sensor (PS-W360) and Water Sensor (PS-WS)



#### Water Sensor

**Model PS-WS**

- Place in a sump or sewage pit (more information on p.11)



#### 360° Water Sensor

**Model PS-W360**

- Patented 360° sensing technology will detect water when placed on any side, top or bottom



### 360° Water Alarm

**Model PWA-360**

- Place a water alarm wherever there is a risk of water damage
- Patented In-Touch 360° sensing technology will detect water when placed on any side, top or bottom
- Easy-to-use, dependable protection
- Waterproof rating of IP67



**Example of multiple 360° Water Sensors connected to one water alarm**

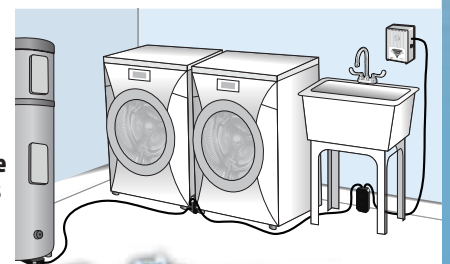

# Check Valves

## Check Valves

MODEL	DESCRIPTION
<b>Booted Check Valves</b>	
PS-CCV1	1½" Klunkless (Quiet) Check Valve with Silencing Air Chamber and ½ / 1¼" Rubber Unions
PS-CVRRU15	1½" Check Valve with Two Rubber Unions
PS-CVKSRRU15	1½" PVC Klunkless (Quiet) Check Valve with Two Rubber Unions
<b>Screw-In Check Valves</b>	
PS-CVW125	1¼" Screw-in Check Valve and 1½" On Top with Weep Hole and No Couplings
PS-CVW15	1½" Screw-in Check Valve with Weep Hole, No Couplings
PS-CVWRU	1½" Screw-in Check Valve with Weep Hole and Rubber Union
PS-CVWNH	1½" Screw-in Check Valve with Weep Hole and No-Hub Coupling
<b>Slip Check Valves</b>	
PS-CVS15	1½" PVC Check Valve with Slip Connections
PS-CVS20	2" PVC Check Valve with Slip Connections
PS-CVKS15	1½" PVC Klunkless (Quiet) Check Valve with Slip Connections
PS-CVKS20	2" PVC Klunkless (Quiet) Check Valve with Slip Connections
<b>Slip Union Check Valves</b>	
PS-CVSU15	1½" PVC Check Valve with Slip Union Connections
PS-CVSU20	2" PVC Check Valve with Slip Union Connections
PS-CVKSU15	1½" PVC Klunkless (Quiet) Check Valve with Slip Union Connections
PS-CVKSU20	2" PVC Klunkless (Quiet) Check Valve with Slip Union Connections
PS-CVBVSU20	2" PVC Check Valve and Ball Valve with Slip Union Connections
PS-CVKBVSU20	2" PVC Klunkless (Quiet) Check Valve and Ball Valve with Slip Union Connections
<b>Compression Check Valves</b>	
PS-CVC15	1½" PVC Check Valve with Compression Connections
PS-CVC20	2" PVC Check Valve with Compression Connections
PS-CVKC15	1½" PVC Klunkless (Quiet) Check Valve with Compression Connections
PS-CVKC20	2" PVC Klunkless (Quiet) Check Valve with Compression Connections
PS-CVBVC20	2" PVC Check Valve and Ball Valve with Compression Connections
PS-CVKBVC20	2" PVC Klunkless (Quiet) Check Valve and Ball Valve with Compression Connections
<b>Ball Valves</b>	
PS-BVS15	1½" PVC Ball Valve
PS-BVS20	2" PVC Ball Valve
<b>KEY:</b>	CV – Check Valve, K – Klunkless (Quiet), S – Slip, C – Compression, SU – Slip Union, RU – Rubber Union, W – Weep Hole, BV – Ball Valve



Slip Connection



Slip Union Connection



The Original Klunkless (Quiet) Check Valve



Compression Connection



Screw-in Connection



Ball Valve

## Quick Connect Main Pipe

### Makes Sump Pump Replacement and Installation Easy

- No need to remove the pipe from the old pump!
- Save time—no need to cut, drill, prime and glue PVC
- Save on cost of adapters, PVC, primer and cement

#### Two Sizes:

##### Model PS-MP

- Total length: 14.25"

##### Model PS-MPE

- Total length: 19.25"

#### Pre-assembled with:

1. 1½" Rubber Union
2. 1½" Check Valve
3. 1½" NPT Female Adapter
4. Pre-Drilled Weep Hole
5. 1½" Discharge Pipe
6. 1½" NPT Threaded Male Adapter





**Glentronics, Inc.**  
645 Heathrow Dr. • Lincolnshire, IL 60069  
(800) 991-0466 • [www.StopFlooding.com](http://www.StopFlooding.com)

As we are continuously improving our products, the items supplied may not agree in all details with the descriptions and specifications shown. We make every effort to provide our customers with superior products; however, Glentronics, Inc. reserves the right to change or discontinue any product without prior notice.

12/21  
1807049