

20.6 Cubic Foot Top Mount Refrigerator

HRT21R2APP

Available



Unit Specifications

Width	31.20"
Depth	33.60"
Height	67"
Weight	208 lbs.
UPC	688057309422 (White) 688057309439 (Black)

More Easy-To-Use Features

- Tri-Light LED Lighting
- Full Width Adjustable Spill Proof Glass
- Two Clear Humidity Crispers
- Full Width Clear Gallon Bin
- Full Width Clear 2-Liter Bin
- Clear Dairy Bin
- Full Width Adjustable Freezer Spill Proof Glass
- Full Width Clear Freezer Bins
- Ice Maker Ready
- Smooth Reversible Door
- Designed, Engineered and Assembled in the USA

Signature Features

Adjustable Spill Proof Glass Shelves

Allows flexible storage solutions and hold liquid spills for easy cleanup

Clear Humidity Controlled Crispers

Provide the ideal environment for storing your fruits and vegetables while optimizing food preservation

Three Levels of LED Lighting

Longer-lasting and uses less energy than incandescent lighting while providing clear bright light on your food items

4-Sided Clear Door Bins

Accommodate small to large items and contain spills while freeing up precious shelf space

Warranty

- 1 Year Warranty (Parts and Labor)

- 5 Year Sealed System

Available Finishes



HRT21R2APP



HRT21R2APE

Letter	Cutout Dimension	in.
A	Width	31.20"
B	Height of Case (Without Hinge)	66.60"
C	Height (With Hinge Cover)	67"
D	Depth of Case (Without Door)	27.90"
E	Depth (Without Handle)	31.40"
F	Depth (With Handle)	33.60"
G	Depth (Door at 90°)	60.40"

Overall Packaging Details	
Packaging	lb./in.
Gross Weight	223 lb.
Dimensions	W 33.38"
	D 33.63"
	H 69.13"

Required Air Clearances

Top	1"
Back	2"
Sides	1"

Power/Ratings

Electrical Rating	115V, 60Hz
Energy Use	432kWh

Product Technical Illustration

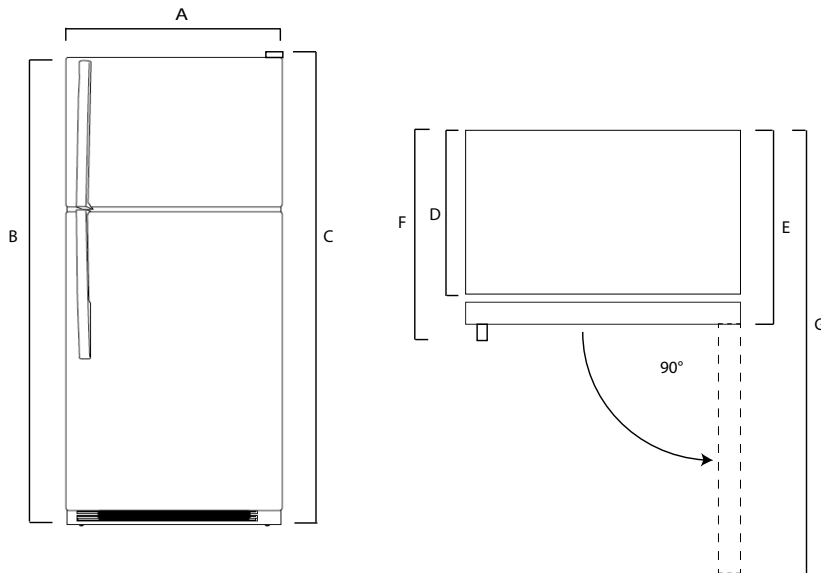

CABINET OPENING DIMENSIONS

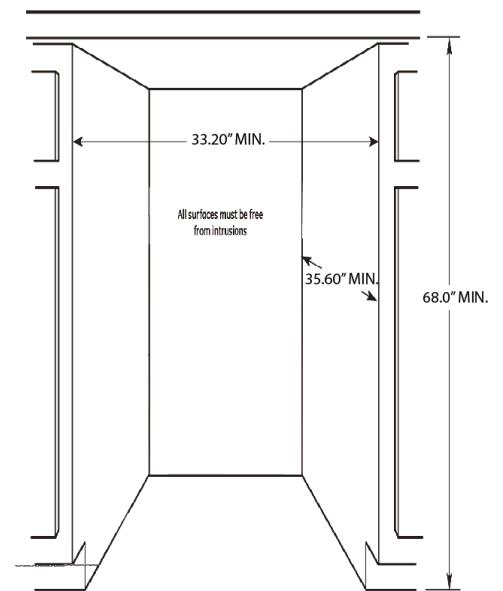

General Appliance Information

Please read all installation details and instructions before use.

Contact Us

For questions regarding this product please refer to our website at haieramerica.com or call our customer service center at 877-337-3639.

