

GENERAL INFORMATION

WOOD-KNOCKER® II+

Concrete Inserts

PRODUCT DESCRIPTION

Wood-Knocker II concrete inserts are specifically designed to provide hangar attachments for mechanical, electrical, plumbing (MEP) and fire protection.

Wood-Knocker II+ concrete inserts are installed onto forms used to support newly poured concrete floor slabs, roof slabs or walls.

When the forms are stripped, the color-coded flange is visibly embedded in the concrete surface. The inserts allow the attachment of steel threaded rod or threaded bolts in sizes ranging from 1/4" to 3/4" in diameter, including a 3/8-1/2" multi insert. The hex impact plate offers resistance to rotation within the concrete as a steel threaded rod or threaded bolt is being installed.

GENERAL APPLICATIONS AND USES

- Hanging Pipe and Sprinkler Systems
- HVAC Ductwork and Strut Channels
- Suspending Trapeze and Cable Trays
- Mechanical Unit Overhead Utilities
- Conduit and Lighting System
- Seismic Loading and Cracked Concrete

FEATURES AND BENEFITS

- + Fast and simple to install, low installed cost
- + Color coded by size for simple identification
- + Wood-Knocker II+ can be installed in form pours only 3.5" thick
- + Hex head does not rotate when set
- + Insert design allows for full thread engagement
- + All sizes suitable for tension and shear loading

APPROVALS AND LISTINGS

- International Code Council, Evaluation Service (ICC-ES), ESR-3657 for concrete - approved for seismic and wind loading
- Code compliant with the 2015 IBC, 2015 IRC, 2012 IBC, 2012 IRC, 2009 IBC, and 2009 IRC
- Tested in accordance with ASTM E488 and ICC-ES AC446 for use in concrete under the design provisions of ACI 318 (Strength Design method)
- Evaluated and qualified by an accredited independent testing laboratory for recognition in cracked and uncracked concrete
- Underwriters Laboratories (UL Listed) - File No. EX1289, see listing for sizes. Also UL listed and recognized for use in air handling spaces.
- FM Approvals (Factory Mutual) – File No. J.I. 3059197

GUIDE SPECIFICATIONS

CSI Divisions: 03 15 19 - Cast-In Concrete Anchors and 03 16 00 - Concrete Anchors. Concrete inserts shall be Wood-Knocker II+ as supplied by DEWALT, Towson, MD. Anchors shall be installed in accordance with published instructions and the Authority Having Jurisdiction.

SECTION CONTENTS

General Information.....	1
Material Specifications	2
Installation Instructions	2
Installation Specifications	2
Reference Data (ASD).....	3
Strength Design (SD).....	4
Ordering Information.....	7



WOOD-KNOCKER II+
FORM INSERT

ANCHOR MATERIALS

- Carbon Steel and Engineered Plastic

ROD/ANCHOR SIZE RANGE (TYP.)

- 1/4" to 3/4" threaded rod for Wood-Knocker Concrete Inserts

SUITABLE BASE MATERIALS

- Normal-weight Concrete
- Lightweight Concrete



MATERIAL SPECIFICATIONS

Wood-Knocker II+

Anchor Component	Component Material
Insert Body	AISI 1008 Carbon Steel or equivalent
Flange	Engineered Plastic
Zinc Plating	ASTM B 633 (Fe/Zn5) Min. plating requirements for mild service condition

Material Properties for Threaded Rod

Steel Description	Steel Specification (ASTM)	Rod Diameter (inch)	Minimum Yield Strength, f_y (ksi)	Minimum Ultimate Strength, f_u (ksi)
Standard carbon rod	A 36 or A 307, Grade C	1/4 to 3/4	36.0	58.0
High strength carbon rod	A 193, Grade B7	1/4 to 3/4	105.0	125.0

INSTALLATION INSTRUCTIONS

Installation Instructions for Wood-Knocker II+

Position

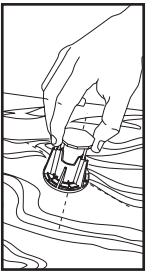

Step 1
Position insert on formwork plastic down.

Drive

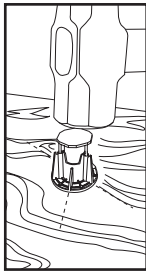

Step 2
Drive insert head down until head contacts plastic (or mount/screw down no nail versions).

Prepare

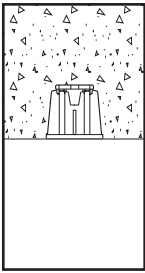

Step 3
After formwork removal, remove nails/screws as necessary (e.g. flush mounted fixtures).

Attach

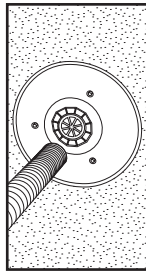

Step 4
After concrete pour and cure, install threaded steel element (rod/bolt) into the insert by firmly pushing threaded rod through plastic center to puncture thread seal. Attach fixture as applicable (e.g. seismic brace).

INSTALLATION SPECIFICATIONS

Wood-Knocker II+ Cast-In-Place Inserts for Form Pour Concrete

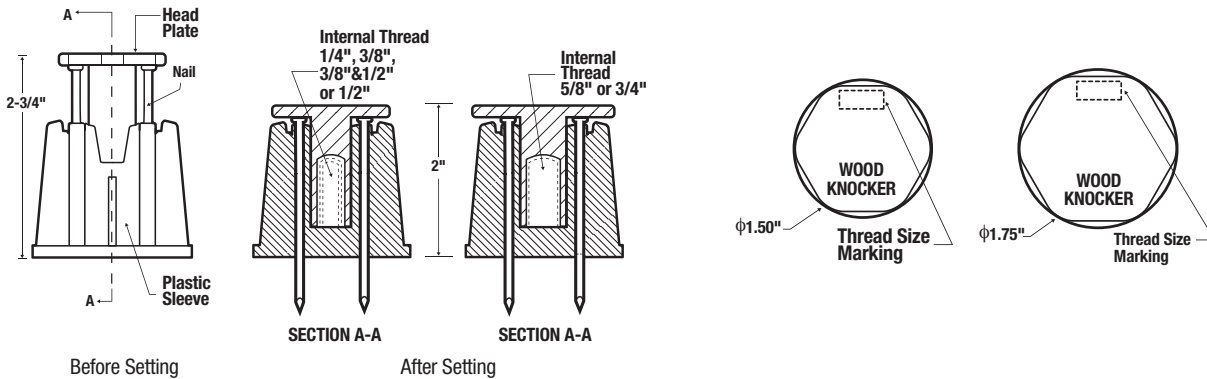

Wood-Knocker II+

Dimension	Notation	Nominal Rod/Anchor Size						
		1/4"	3/8"	3/8" & 1/2" Multi		1/2"	5/8"	3/4"
Thread Size, UNC	-	1/4-20	3/8-16	3/8-16	1/2-13	1/2-13	5/8-11	3/4-10
Approx. Internal Thread Length (in.)	-	3/8	5/8	9/16	9/16	11/16	15/16	1-1/8
Approx. Internal Thread Standoff from Plastic Sleeve Bottom, after setting (in.)	-	3/8	3/8	15/16	3/8	3/8	3/8	3/8
Plastic Sleeve Flange Dia. (in.)	d_{pf}	2-3/8	2-3/8	2-3/8		2-3/8	2-3/8	2-3/8
Plastic Sleeve Flange Thickness (in.)	-	3/16	3/16	3/16		3/16	3/16	3/16
Overall Length, after setting (in.)	ℓ	2	2	2		2	2	2
Break-Off Nail Length (in.)	ℓ_n	3/4	3/4	3/4		3/4	3/4	3/4
Steel Head Plate Thickness (in.)	t_{sh}	1/8	1/8	1/8		1/8	1/8	1/8

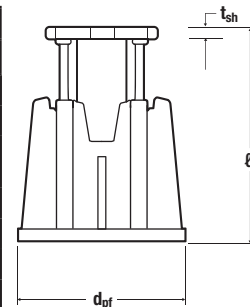

WOOD-KNOCKER® II+
Concrete Inserts

REFERENCE DATA (ASD)

Ultimate and Allowable Load Capacities for Wood-Knocker II+ Inserts Installed in Normal-Weight Concrete^{1,2,3}



Rod/Insert Diameter d in.	Nominal Embedment Depth h _v in.	Insert Spacing in.	Edge Distance in.	Minimum Concrete Compressive Strength (f' _c)							
				3,000 psi				4,500 psi			
				Ultimate Load		Allowable Load		Ultimate Load		Allowable Load	
				Tension lbs.	Shear lbs.	Tension lbs.	Shear lbs.	Tension lbs.	Shear lbs.	Tension lbs.	Shear lbs.
1/4	2	6	6	3,720	1,490	1,240	495	4,250	1,610	1,415	535
3/8	2	6	6	4,820	5,330	1,605	1,775	7,190	5,620	2,395	1,875
1/2	2	6	6	4,820	7,400	1,605	2,465	7,190	8,590	2,395	2,865
5/8	2	6	6	4,650	11,360	1,550	3,785	7,350	13,010	2,450	4,335
3/4	2	6	6	4,650	11,360	1,550	3,785	7,350	14,590	2,450	4,865

1. Allowable load capacities listed are calculated using an applied safety factor of 3.0.
2. The allowable working load must be the lesser of the insert capacity or the steel strength of the threaded rod.
3. Linear interpolation may be used to determine ultimate loads for intermediate compressive strengths.

Ultimate and Allowable Load Capacities for Wood-Knocker II+ Inserts Installed in Sand-lightweight Concrete^{1,2}



Rod/Insert Diameter d in.	Nominal Embedment Depth h _v in.	Insert Spacing in.	Edge Distance in.	f' _c ≥ 3,000 psi			
				Ultimate Load		Allowable Load	
				Tension lbs.	Shear lbs.	Tension lbs.	Shear lbs.
1/4	2	6	6	3,570	1,380	1,190	460
3/8	2	6	6	4,270	5,280	1,425	1,760
1/2	2	6	6	4,270	7,180	1,425	2,395
5/8	2	6	6	4,600	7,590	1,535	2,530
3/4	2	6	6	4,600	7,590	1,535	2,530

1. Allowable load capacities listed are calculated using an applied safety factor of 3.0.
2. The allowable working load must be the lesser of the insert capacity or the steel strength of the threaded rod.
3. For 1/4", 3/8" and 1/2" diameters: When the inserts are spaced 3" center-to-center the inserts allowable tension capacity must be reduced by 25 percent and the allowable shear capacity reduced by 15 percent. When the inserts have a 3" edge distance the inserts allowable tension capacity does not require a reduction and the allowable shear capacity must be reduced by 40 percent.

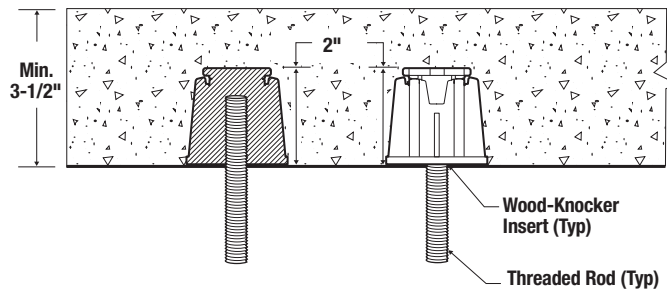

Allowable Steel Strength for Threaded Rod



Anchor Diameter d in.	Nominal Area of Rod in. ²	Allowable Tension			Allowable Shear		
		ASTM A36 lbs.	ASTM A307 Grade C lbs.	ASTM A193 Grade B7 lbs.	ASTM A36 lbs.	ASTM A307 Grade C lbs.	ASTM A193 Grade B7 lbs.
1/4	0.0491	940	940	2,160	485	485	1,030
3/8	0.1104	2,115	2,115	4,375	1,090	1,090	2,255
1/2	0.1963	3,755	3,755	7,775	1,940	1,940	4,055
5/8	0.3068	5,870	5,870	12,150	3,025	3,025	6,260
3/4	0.4418	8,455	8,455	17,495	4,355	4,355	9,010

Allowable tension = f_u (A_{nom}) (0.33); Allowable shear = f_u (A_{nom}) (0.17)

STRENGTH DESIGN (SD)



Wood-Knocker II+ Insert Design Information 1,2,3,4,5,6,7,8

Design Information	Symbol	Units	1/4-inch	3/8-inch	1/2-inch	5/8-inch	3/4-inch
Insert O.D.	d_a (d_o)	in. (mm)	0.7 (18)	0.7 (18)	0.7 (18)	1.0 (25)	1.0 (25)
Insert head net bearing area	A_{brg}	in ² (mm ²)	1.20 (762)	1.20 (762)	1.20 (762)	1.30 (839)	1.30 (839)
Effective embedment depth	h_{ef}	in. (mm)	1.75 (45)	1.75 (45)	1.75 (45)	1.75 (45)	1.75 (45)
Minimum member thickness	h_{min}	-	3.5 (89)	3.5 (89)	3.5 (89)	3.5 (89)	3.5 (89)
Effectiveness factor for cracked concrete	k_c	- (SI)	24 (10)	24 (10)	24 (10)	24 (10)	24 (10)
Modification factor for tension strength in uncracked concrete	$\Psi_{C,N}$	-	1.25	1.25	1.25	1.25	1.25
Nominal tension strength of single insert as governed by steel strength	$N_{sa,insert}$	lb (kN)	10,270 (45.7)	10,270 (45.7)	9,005 (40.1)	12,685 (56.4)	12,685 (56.4)
Nominal tension strength of single insert as governed by steel strength, for seismic loading	$N_{sa,insert,eq}$	lb (kN)	10,270 (45.7)	10,270 (45.7)	9,005 (40.1)	12,685 (56.4)	12,685 (56.4)
Nominal steel shear strength of single insert	$V_{sa,insert}$	lb (kN)	7,180 (31.9)	7,180 (31.9)	7,180 (31.9)	9,075 (40.4)	9,075 (40.4)
Nominal steel shear strength of single insert, for seismic loading	$V_{sa,insert,eq}$	lb (kN)	7,180 (31.9)	7,180 (31.9)	7,180 (31.9)	9,075 (40.4)	9,075 (40.4)

For St: 1 inch = 25.4 mm, 1 inch² = 635 mm², 1 pound = 0.00445 kN, 1 psi = 0.006895 MPa. For pound-inch unit: 1 mm = 0.03937 inches.

- Concrete must have a compressive strength f'_c of 2,500 psi minimum.
- Design of headed cast-in specialty inserts shall be in accordance with the provisions of ACI 318-14 Chapter 17 or ACI 318-11 Appendix D for cast-in headed anchors.
- Strength reduction factors (ϕ) for the inserts are based on ACI 318-14 17.3.3 or ACI 318-11 D.4.3 for cast-in headed anchors. Condition B is assumed. Strength reduction factors for load combinations in accordance with ACI 318-14 Section 5.3 or ACI 318-11 Section 9.2 governed by steel strength of the insert are taken as 0.65 for tension and 0.60 for shear; values correspond to brittle steel elements. The value of ϕ applies when the load combinations of IBC Section 1605.2, ACI 318-14 Section 5.3 or ACI 318-11 Section 9.2 are used in accordance with ACI 318-14 17.3.3 or ACI 318-11 D.4.3. If the load combinations of ACI 318-11 Appendix C are used, then the appropriate value of ϕ must be determined in accordance with ACI 318-11 D.4.4.
- The concrete tension strength of headed cast-in specialty inserts shall be calculated in accordance with ACI 318-14 Chapter 17 or ACI 318-11 Appendix D.
- Insert O.D. is the outside diameter of the headed insert body.
- Only the largest size of threaded rod or bolt for the 3/8 & 1/2 inch multi insert must be used for applications resisting shear loads.
- Minimum spacing distance between anchors and minimum edge distance for cast-in Wood-Knocker II+ anchors shall be in accordance with ACI 318-14 17.7 or ACI 318-11 D.8.
- The strengths shown in the table are for inserts only. Design professional is responsible for checking threaded rod or bolt strength in tension, shear, and combined tension and shear, as applicable. See Steel Design Information table for common threaded rod elements.

Wood-Knocker II+ Insert Installed in Soffit of Form Pour Concrete Floor and Roof Assemblies

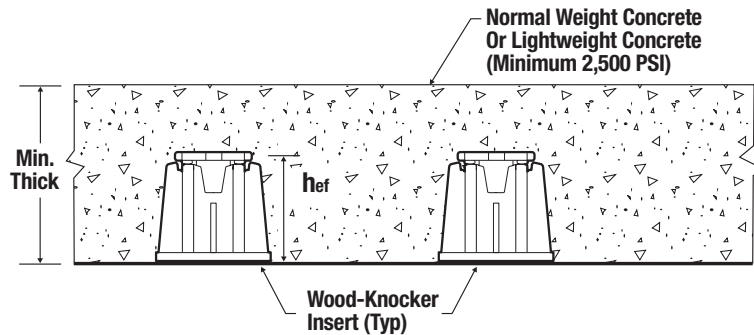

Specifications And Physical Properties Of Common Carbon Steel Threaded Rod Elements¹



Threaded Rod Specification		Units	Min. Specified Ultimate Strength, F_{uts}	Min. Specified Yield Strength 0.2 Percent Offset, F_{ys}	$F_{uts} - F_{ys}$	Elongation Minimum Percent ⁶	Reduction Of Area Min. Percent	Related Nut Specification ²
Carbon Steel	ASTM A36/A36M ² and F1554 ³ Grade 36	psi (MPa)	58,000 (400)	36,000 (248)	1.61	23	40 (50 for A36)	ASTM A194 / A563 Grade A
	ASTM F1554 ³ Grade 105	psi (MPa)	125,000 (862)	105,000 (724)	1.19	15	45	ASTM A194 / A563 Grade DH
	ASTM A193/A193M ⁴ Grade B7	psi (MPa)	125,000 (860)	105,000 (720)	1.19	16	50	

For SI: 1 inch = 25.4 mm, 1 psi = 0.006897 MPa. For pound-inch units: 1 mm = 0.03937 inch, 1 MPa = 145.0 psi.

1. Inserts may be used in conjunction with all grades of continuously threaded carbon steels (all-thread) that comply with code reference standards and that have thread characteristics comparable with ANSI B1.1 UNC Coarse Thread Series.
2. Standard Specification for Carbon Structural Steel.
3. Standard Specification for Anchor Bolts, Steel, 36, 55, and 105-ksi Yield Strength.
4. Standard Specification for Alloy-Steel and Stainless Steel Bolting Materials for High Temperature or High Pressure Service and Other Special Purpose Applications.
5. Based on 2-inch (50 mm) gauge length except ASTM A193, which are based on a gauge length of 4d (d_{rod}).
6. Where nuts are applicable, nuts of other grades and style having specified proof load stress greater than the specified grade and style are also suitable.

Steel Design Information For Common Threaded Rod Elements Used With Concrete Inserts^{1,2,3,4}



Design Information	Symbol	Units	1/4-inch	3/8-inch	1/2-inch	5/8-inch	3/4-inch
Threaded rod nominal outside diameter	d_{rod}	in. (mm)	0.250 (6.4)	0.375 (9.5)	0.500 (12.7)	0.625 (15.9)	0.750 (19.1)
Threaded rod effective cross-sectional area	A_{se}	in ² (mm ²)	0.032 (21)	0.078 (50)	0.142 (92)	0.226 (146)	0.335 (216)
Nominal tension strength of ASTM A36 threaded rod as governed by steel strength	$N_{sa,rod,A36}$	lb (kN)	1,855 (8.2)	4,525 (20.0)	8,235 (36.6)	13,110 (58.3)	19,430 (86.3)
Nominal seismic tension strength of ASTM A36 threaded rod as governed by steel strength	$N_{sa,rod,A36,eq}$	lb (kN)	1,855 (8.2)	4,525 (20.0)	8,235 (36.6)	13,110 (58.3)	19,430 (86.4)
Nominal tension strength of ASTM A193, Gr. B7 threaded rod as governed by steel strength	$N_{sa,rod,B7}$	lb (kN)	4,000 (17.7)	9,750 (43.1)	17,750 (78.9)	28,250 (125.7)	41,875 (186.0)
Nominal seismic tension strength of ASTM A193, Gr. B7 threaded rod as governed by steel strength	$N_{sa,rod,B7,eq}$	lb (kN)	4,000 (17.7)	9,750 (43.1)	17,750 (78.9)	28,250 (125.7)	41,875 (186.0)
Nominal shear strength of ASTM A36 threaded rod as governed by steel strength	$V_{sa,rod,A36}$	lb (kN)	1,115 (4.9)	2,715 (12.1)	4,940 (22.0)	7,865 (35.0)	11,660 (51.9)
Nominal seismic shear strength of ASTM A36 threaded rod as governed by steel strength	$V_{sa,rod,A36,eq}$	lb (kN)	780 (3.5)	1,900 (8.4)	3,460 (15.4)	5,505 (24.5)	8,160 (36.3)
Nominal shear strength of ASTM A193, Gr. B7 threaded rod as governed by steel strength	$V_{sa,rod,B7}$	lb (kN)	2,385 (10.6)	5,815 (25.9)	10,640 (47.3)	16,950 (75.4)	25,085 (111.6)
Nominal seismic shear strength of ASTM A193, Gr. B7 threaded rod as governed by steel strength	$V_{sa,rod,B7,eq}$	lb (kN)	1,680 (7.5)	4,095 (18.2)	7,455 (33.2)	11,865 (52.8)	17,590 (78.2)

For SI: 1 inch = 25.4 mm, 1 pound = 0.00445 kN, 1 in² = 645.2 mm². For pound-inch unit: 1 mm = 0.03937 inches.

1. Values provided for steel element material types based on minimum specified strengths and calculated in accordance with ACI 318-11 Eq. (D-2) and Eq. (D-29).
2. ϕN_{sa} shall be the lower of the $\phi N_{sa,rod}$ or $\phi N_{sa,insert}$ for static steel strength in tension; for seismic loading $\phi N_{sa,eq}$ shall be the lower of the $\phi N_{sa,rod,eq}$ or $\phi N_{sa,insert,eq}$.
3. ϕV_{sa} shall be the lower of the $\phi V_{sa,rod}$ or $\phi V_{sa,insert}$ for static steel strength in tension; for seismic loading $\phi V_{sa,eq}$ shall be the lower of the $\phi V_{sa,rod,eq}$ or $\phi V_{sa,insert,eq}$.
4. Strength reduction factors shall be taken from ACI 318-14 17.3.3 or ACI 318-11 D.4.3 for steel elements. Condition B is assumed. Strength reduction factors for load combinations in accordance with ACI 318-14 Section 5.3 or ACI 318-11 Section 9.2 governed by steel strength of the threaded rod are taken as 0.75 for tension and 0.65 for shear; values correspond to ductile steel elements. The value of ϕ applies when the load combinations of IBC Section 1605.2, ACI 318-14 Section 5.3 or ACI 318-11 Section 9.2 are used in accordance with ACI 318-14 17.3.3 or ACI 318-11 D.4.3. If the load combinations of ACI 318-11 Appendix C are used, then the appropriate value of ϕ must be determined in accordance with ACI 318-11 D4.4.



Tension and Shear Design Strengths for Wood-Knocker II+ Insert Installed in the Soffit of Form Poured Concrete and Roof Assemblies - Uncracked Concrete^{1,2,3,4,5,6}

Nominal Anchor Diameter	Embed. Depth h_{ef} (in.)	Minimum Concrete Compressive Strength					
		$f'_c = 3,000$ psi		$f'_c = 4,000$ psi		$f'_c = 6,000$ psi	
		ϕN_n Tension (lbs.)	ϕV_n Shear (lbs.)	ϕN_n Tension (lbs.)	ϕV_n Shear (lbs.)	ϕN_n Tension (lbs.)	ϕV_n Shear (lbs.)
1/4	1-3/4	2,665	2,420	3,075	2,795	3,765	3,425
3/8	1-3/4	2,665	2,420	3,075	2,795	3,765	3,425
1/2	1-3/4	2,665	2,420	3,075	2,795	3,765	3,425
5/8	1-3/4	2,665	2,665	3,075	3,075	3,765	3,765
3/4	1-3/4	2,665	2,665	3,075	3,075	3,765	3,765

■ - Anchor Pullout/Pryout Strength Controls
 ■ - Concrete Breakout Strength Controls
 ■ - Steel Strength Controls

Tension and Shear Design Strengths for Wood-Knocker II+ Insert Installed in the Soffit of Form Poured Concrete and Roof Assemblies - Cracked Concrete^{1,2,3,4,5,6}

Nominal Anchor Diameter	Embed. Depth h_{ef} (in.)	Minimum Concrete Compressive Strength					
		$f'_c = 3,000$ psi		$f'_c = 4,000$ psi		$f'_c = 6,000$ psi	
		ϕN_n Tension (lbs.)	ϕV_n Shear (lbs.)	ϕN_n Tension (lbs.)	ϕV_n Shear (lbs.)	ϕN_n Tension (lbs.)	ϕV_n Shear (lbs.)
1/4	1-3/4	2,130	1,730	2,460	2,000	3,015	2,445
3/8	1-3/4	2,130	1,730	2,460	2,000	3,015	2,445
1/2	1-3/4	2,130	1,730	2,460	2,000	3,015	2,445
5/8	1-3/4	2,130	2,130	2,460	2,460	3,015	3,015
3/4	1-3/4	2,130	2,130	2,460	2,460	3,015	3,015

■ - Anchor Pullout/Pryout Strength Controls
 ■ - Concrete Breakout Strength Controls
 ■ - Steel Strength Controls

- Tabular values are provided for illustration and are applicable for single anchors installed in normal-weight concrete with minimum slab thickness, $h_a = h_{min}$, and with the following conditions:
 - C_{a1} is greater than or equal to the critical edge distance, C_{ac} .
 - C_{a2} is greater than or equal to 1.5 times C_{a1} .
- Calculations were performed following methodology in ACI 318-14 Chapter 17 or ACI 318-11 Appendix D. The load level corresponding to the failure mode listed [steel strength of insert ($N_{sa,insert}$, $V_{sa,insert}$), concrete breakout strength, or pryout strength] must be checked against the tabulated steel strength of the corresponding threaded rod type, ($N_{sa,rod}$, $V_{sa,rod}$), the lowest load level controls.
- Strength reduction factors shall be taken from ACI 318-14 17.3.3 or ACI 318-11 D.4.3 for cast-in headed anchors. Condition B is assumed. Strength reduction factors for load combinations in accordance with ACI 318-14 Section 5.3 or ACI 318-11 Section 9.2 governed by steel strength of the insert are taken as 0.70 for tension and 0.60 for shear; values correspond to brittle steel elements.
- Tabular values are permitted for short-term static loads only, seismic loading is not considered with these tables.
- For designs that include combined tension and shear, the interaction of tension and shear loads must be calculated in accordance with ACI 318-14 Chapter 17 or ACI 318-11 Appendix D.
- Interpolation is not permitted to be used with the tabular values. For intermediate base material compressive strengths please see ACI 318-14 Chapter 17 or ACI 318-11 Appendix D and information contained in this product supplement. For other design conditions including seismic considerations please see ACI 318-14 Chapter 17 or ACI 318-11 Appendix D.

Tension and Shear Design Strength of Steel Elements (Steel Strength)^{1,2,3,4}

Nominal Rod Diameter (in. or No.)	Steel Elements - Threaded Rod			
	ASTM A36 and ASTM F1554 Grade 36		ASTM A193 Grade B7 and ASTM F1554 Grade 105	
	$\phi N_{sa,rod}$ Tension (lbs.)	$\phi V_{sa,rod}$ Shear (lbs.)	$\phi N_{sa,rod}$ Tension (lbs.)	$\phi V_{sa,rod}$ Shear (lbs.)
1/4	1,390	720	3,000	1,550
3/8	3,395	1,750	7,315	3,780
1/2	6,175	3,210	13,315	6,915
5/8	9,835	5,115	21,190	11,020
3/4	14,550	7,565	31,405	16,305

■ - Steel Strength Controls

- Steel tensile design strength according to ACI 318 Appendix D and ACI 318 Chapter 17, $\phi N_{sa} = \phi \cdot A_{se,N} \cdot f_{uta}$
- The tabulated steel design strength in tension for the threaded rod must be checked against the design strength of the steel insert, concrete breakout and pullout design strength to determine the controlling failure mode, the lowest load level controls.
- Steel shear design strength according to ACI 318 Appendix D and ACI 318 Chapter 17, $\phi V_{sa} = \phi \cdot 0.60 \cdot A_{se,N} \cdot f_{uta}$
- The tabulated steel design strength in shear for the threaded rod must be checked against the design strength of the steel insert, concrete breakout and pryout design strength to determine the controlling failure mode, the lowest load level controls

ORDERING INFORMATION

Wood-Knocker® II+ Form Insert (UNC)

Cat No.	Description	Color Code	Std. Box
PFM2521100	1/4" Wood-Knocker II+ Insert	Brown	100
PFM2521150	3/8" Wood-Knocker II+ Insert	Green	100
PFM2521200	1/2" Wood-Knocker II+ Insert	Yellow	100
PFM2521250	5/8" Wood-Knocker II+ Insert	Red	100
PFM2521300	3/4" Wood-Knocker II+ Insert	Purple	100
PFM2521350	3/8"-1/2" Wood-Knocker II+ Multi Insert	Gray	100

Threaded Inserts are color coded to easily identify location and diameter of the internally threaded coupling, allowing multiple trades on the same job to suspend their systems with various size steel threaded rods.



Wood-Knocker® II+ Form Insert (UNC) with no nails

Cat No.	Description	Color Code	Std. Box
PFM2521100NN	1/4" Wood-Knocker II+ Insert with no nails	Brown	100
PFM2521150NN	3/8" Wood-Knocker II+ Insert with no nails	Green	100
PFM2521200NN	1/2" Wood-Knocker II+ Insert with no nails	Yellow	100
PFM2521250NN	5/8" Wood-Knocker II+ Insert with no nails	Red	100
PFM2521300NN	3/4" Wood-Knocker II+ Insert with no nails	Purple	100
PFM2521350NN	3/8"-1/2" Wood-Knocker II+ Multi Insert with no nails	Gray	100

Wood-Knocker II+ Form Inserts with no nails must be mount/screwed to the concrete form work (screws not included).

