

DESCRIPTION

- Heavy-duty mesh metal ironing board w/cover
- Hot iron storage shelf - accepts irons up to 14" high
- Utility/storage shelf - accepts items up to 13¼" high
- Door included with Model ICUDWH
- Door mounting - both left and right
- Board cover included

MODEL ICUNUW

- Door sold separately

MODEL ICUDWH

- Includes White MDF Door

Additional Doors Available (sold separately):

- ICDRUW Birch Raised Panel – Unfinished
- ICDFUW Birch Flat Panel – Unfinished
- ICDM Mirror Door, Beveled – Unfinished sides and back

See Page 2 for custom door dimensions.

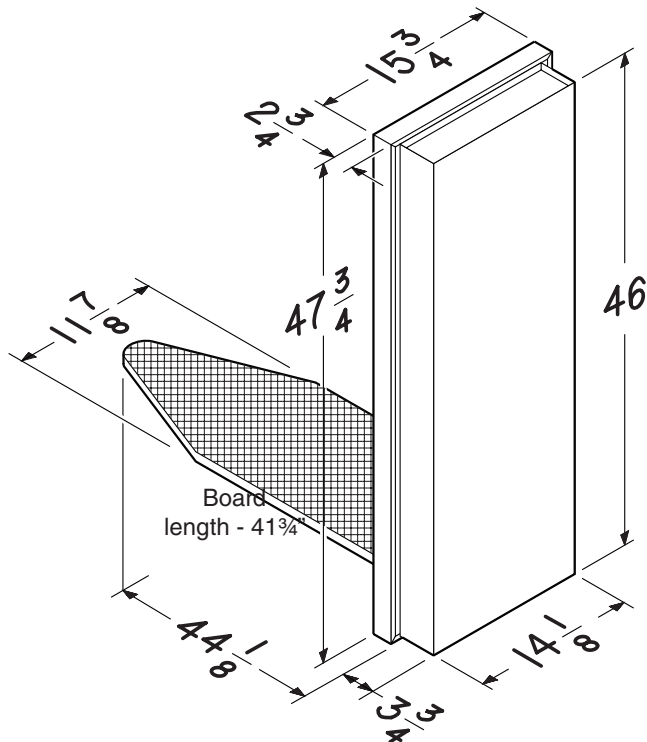

Built-in Ironing Center

MODELS ICUDWH & ICUNUW

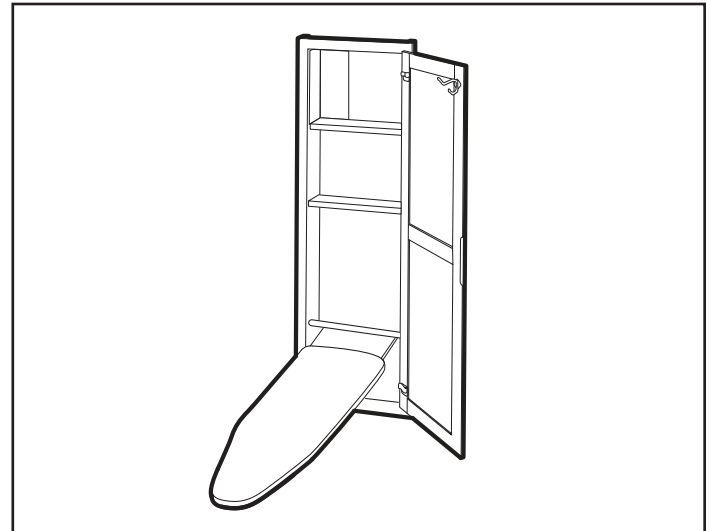

INSTALLATION

For built-in installation.
Installation instructions included with each unit.

ARCHITECT'S SPECIFICATION

Ironing center shall be NuTone Model ICUDWH (ICUNUW).

Model ICUDWH shall be Medium Density Fiberboard (MDF) in white finish with white MDF raised panel door.

Model ICUNUW shall be unfinished solid birch and birch veneer over an MDF core.

All MDF used in the NuTone Ironing Centers shall be CARB 93120 Compliant for Formaldehyde.

A 46¼" H x 14¼" W x 4" D wall opening is required for both models.

Broan-NuTone LLC Hartford, Wisconsin www.nutone.com 888-336-3948

REFERENCE	QTY.	REMARKS	Project	
			Location	
			Architect	
			Engineer	
			Contractor	
			Submitted by	Date

Built-in Ironing Center

MODELS ICUDWH & ICUNUW

Custom Door Dimensions

