



ITT

Wastewater

Goulds Pumps

EP04 & EP05 Series Model 3871

Submersible Effluent Pumps



FEATURES

- **EP04 Impeller:** Thermoplastic semi-open design with pump out vanes for mechanical seal protection.
- **EP05 Impeller:** Thermoplastic enclosed design for improved performance.
- **Casing and Base:** Rugged thermoplastic design provides superior strength and corrosion resistance.
- **Motor Housing:** Cast iron for efficient heat transfer, strength, and durability.
- **Motor Cover:** Thermoplastic cover with integral handle and float switch attachment points.
- **Power Cable:** Severe duty rated oil and water resistant.
- **Bearings:** Upper and lower heavy duty ball bearing construction.



Goulds Pumps is a brand of ITT
Residential and Commercial Water.

www.goulds.com

Engineered for life

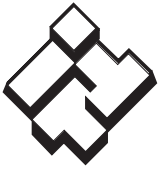

ITT

GOULDS PUMPS Wastewater

APPLICATIONS

Specifically designed for the following uses:

- Effluent systems
- Homes
- Farms
- Heavy duty sump
- Water transfer
- Dewatering

SPECIFICATIONS

- Solids handling capability: $\frac{3}{4}$ " maximum.
- Capacities: up to 60 GPM.
- Total heads: up to 31 feet.
- Discharge size: 1½" NPT.
- Mechanical seal: carbon-rotary/ceramic-stationary, BUNA-N elastomers.
- Temperature:
104° F (40° C) continuous
140° F (60° C) intermittent.
- Fasteners: 300 series stainless steel.
- Capable of running dry without damage to components.

Motor:

- EP04 Single phase: 0.4 HP, 115 or 230 V, 60 Hz, 1550 RPM, built in overload with automatic reset.
- EP05 Single phase: 0.5 HP, 115 V or 230V, 60 Hz, 1550 RPM, built in overload with automatic reset.
- Power cord: 10 foot standard length, 16/3 SJTW with three prong grounding plug. Optional 20 foot length, 16/3 SJTW with three prong grounding plug (standard on EP05).
- Fully submerged in high grade turbine oil for lubrication and efficient heat transfer.

Available for automatic and manual operation.
Automatic models include Mechanical Float Switch assembled and preset at the factory.

AGENCY LISTING



Tested to UL 778 and
CSA 22.2 108 Standards
By Canadian Standards Association
File #LR38549

Goulds Pumps is ISO 9001 Registered.

MODEL INFORMATION

Order No.	HP	Volts	Amps	Minimum Circuit Breaker	Phase	Float Switch Style	Cord Length	Discharge Connection	Minimum On Level	Minimum Off Level	Minimum Basin Diameter	Maximum Solids Size	Shipping Weight lbs/kg
EP0411	.4	115	12	20	1	Plug / No Switch	10'	1½"	Manual	Manual	15"	¾"	20 / 9.1
EP0411A						Piggyback / Wide-Angle	10'	1½"	12"	6"	15"		21 / 9.5
EP0411F						Plug / No Switch	20'	1½"	Manual	Manual	15"		20 / 9.1
EP0411AC						Piggyback / Wide-Angle	20'	1½"	12"	6"	15"		21 / 9.5
EP0412	.4	230	6	10		Plug / No Switch	10'	1½"	Manual	Manual	15"		20 / 9.1
EP0412F						Plug / No Switch	20'	1½"	Manual	Manual	15"		20 / 9.1
EP0511F	.5	115	13	20		Plug / No Switch	20'	1½"	Manual	Manual	15"		22 / 10
EP0511AC						Piggyback / Wide-Angle	20'	1½"	12"	6"	15"		23 / 10.4
EP0512F					Plug / No Switch	20'	1½"	Manual	Manual	15"	22 / 10		

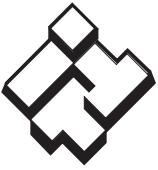

ITT

GOULDS PUMPS Wastewater

PERFORMANCE RATINGS

Total Head (ft. of water)	Gallons Per Minute	
	EP04	EP05
5	53	—
10	46	62
15	36	55
20	21	46
25	0	33
30	—	11

COMPONENTS

Item No.	Description
1	Impeller
2	Base
3	Pump Casing
4	Mechanical Seal
5	Ball Bearings
6	O-Rings
7	Power Cord
8	Oil Filled Motor
9	Motor Housing/ Stator Assembly
10	Motor Cover

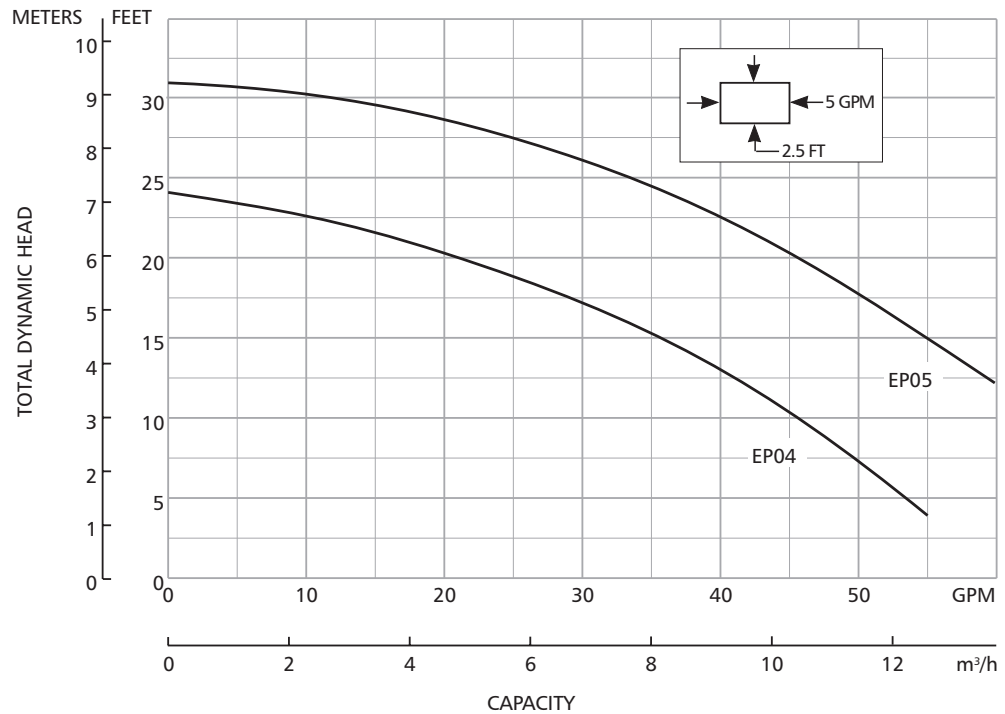
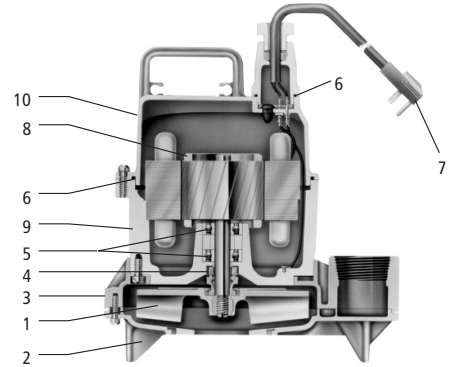

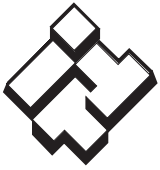

ITT

Wastewater

DIMENSIONS

(All dimensions are in inches. Do not use for construction purposes.)

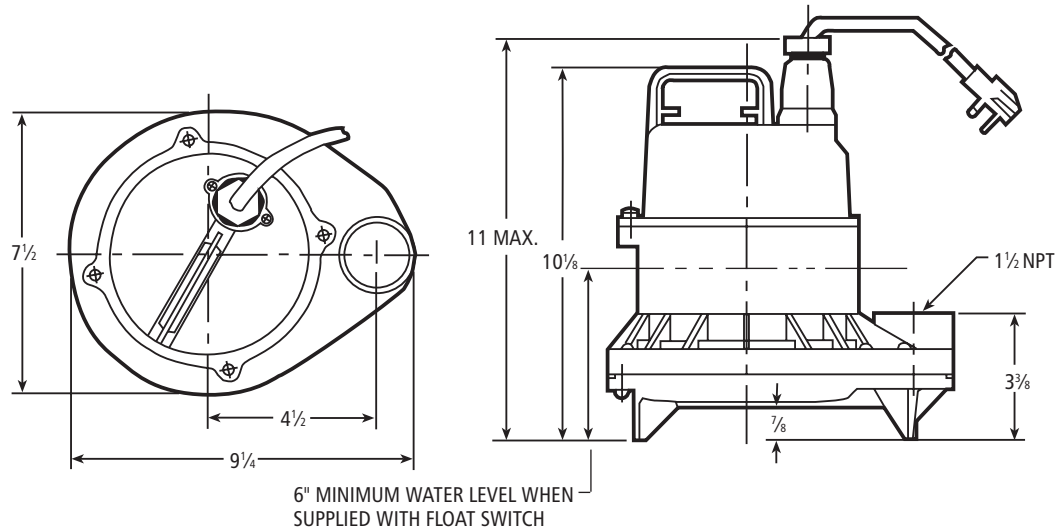

Goulds Pumps and the ITT Engineered Blocks Symbol are registered trademarks and tradenames of ITT Corporation.

SPECIFICATIONS ARE SUBJECT TO CHANGE WITHOUT NOTICE.

B3871 July, 2006

© 2006 ITT Corporation

Engineered for life