

**ADJUST TO DESIRED HEIGHT,  
ACCOUNT FOR AERATOR BOX HEIGHT.**  
(Fig. 1)

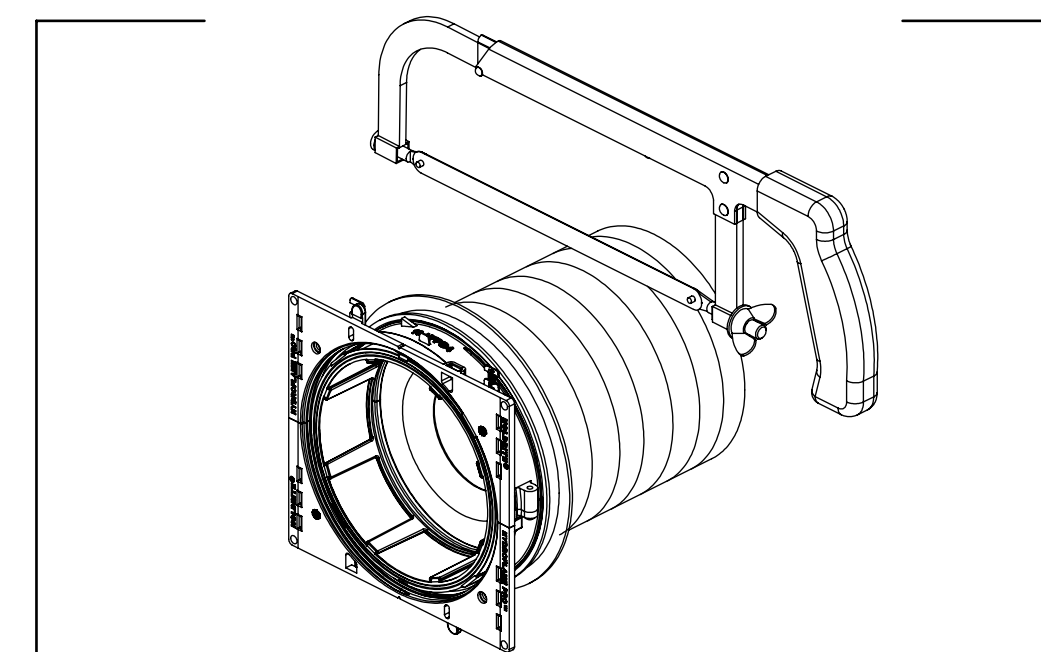

**CUT INNER & OUTER SLEEVE AS  
NEEDED, TO ACCOUNT FOR  
AERATOR BOX HEIGHT.**  
(CAN BE CUT AS SHORT AS 2-1/2")  
(Fig. 2)

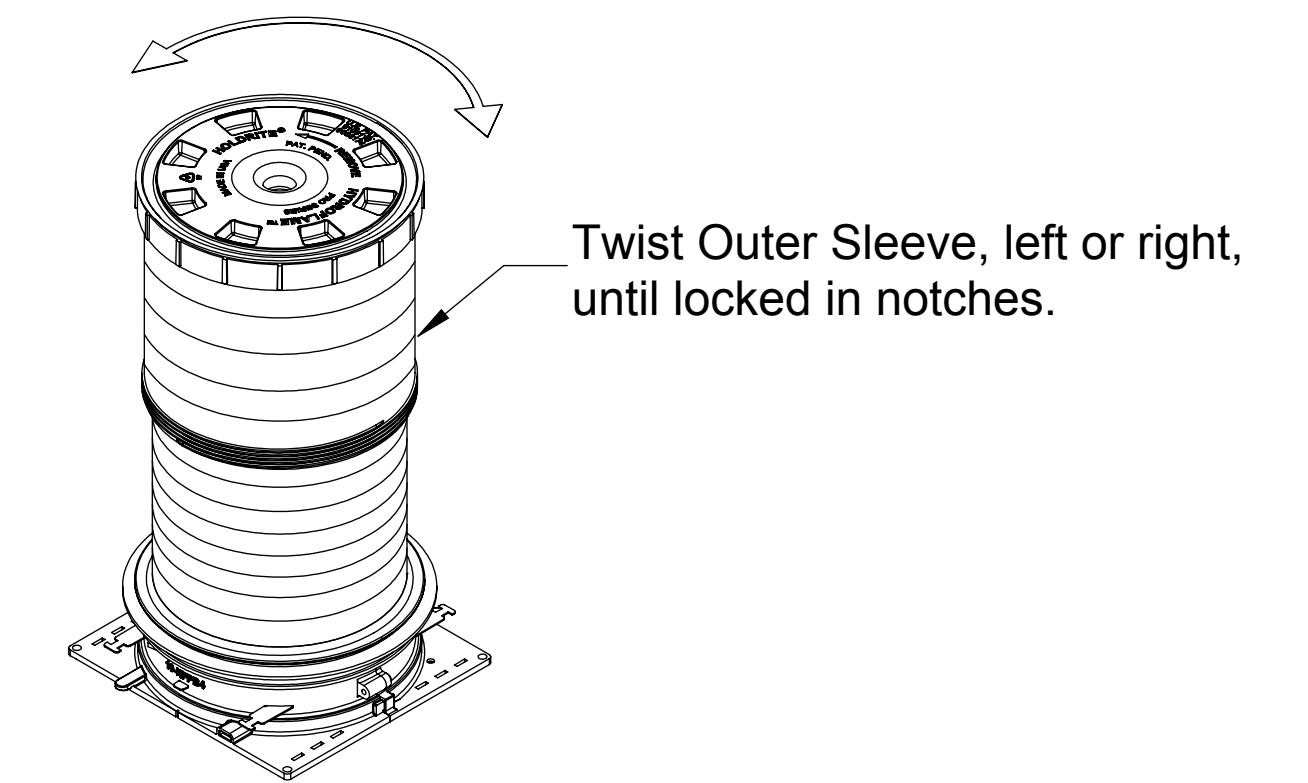

**LOCK OUTER SLEEVE IN PLACE.**  
(NON-TELESCOPING "-B" VERSION SLEEVE CAN ALSO BE USED)  
(Fig. 3)

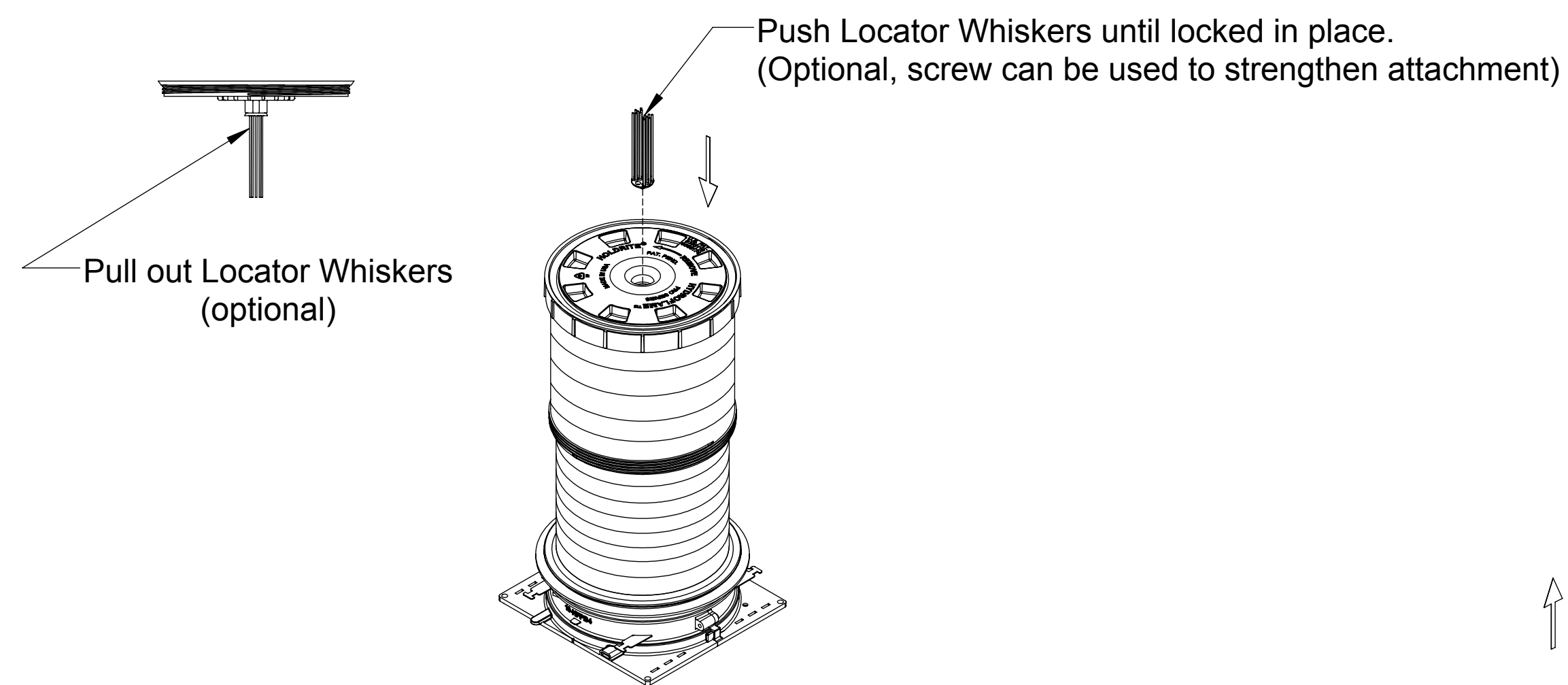

**RE-INSTALL CAP & INSERT LOCATOR WHISKERS.**  
(Fig. 4)

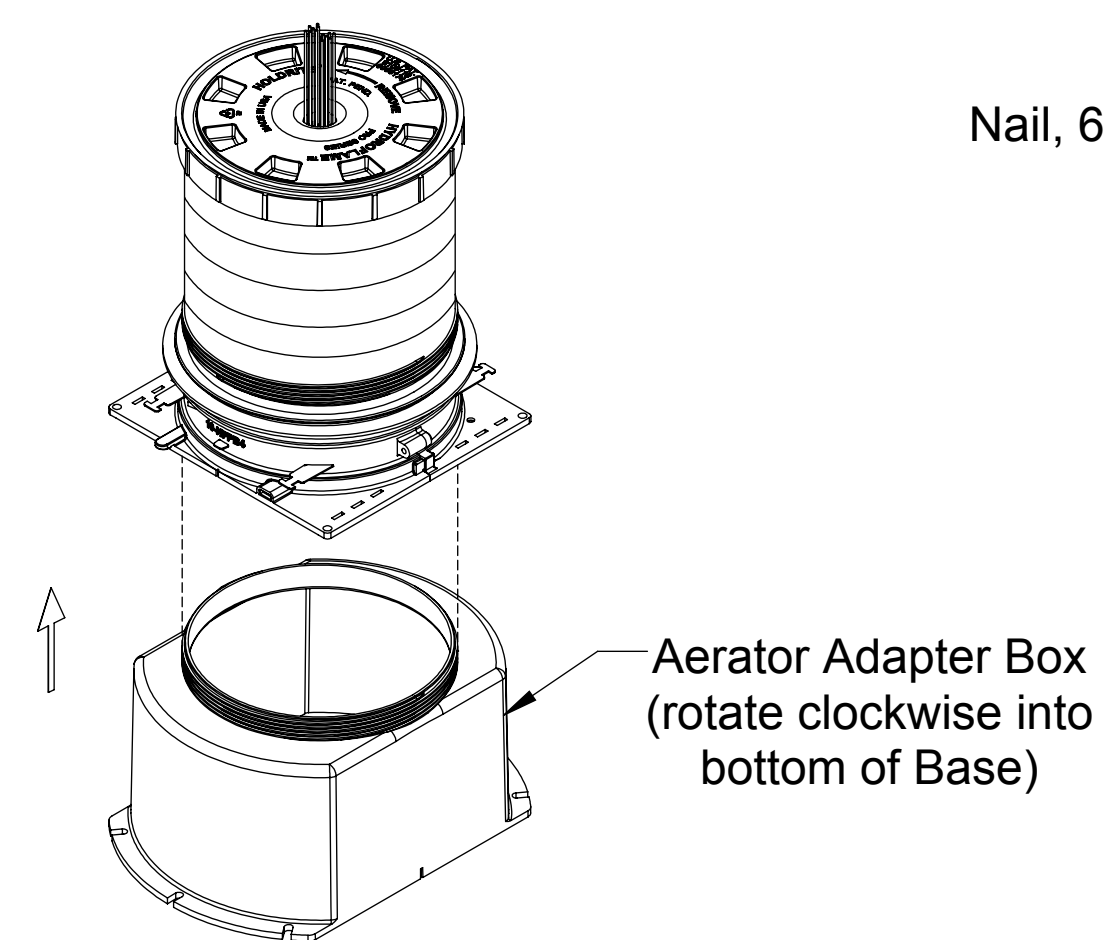

**INSTALL AERATOR ADAPTER BOX.**  
(Fig. 5)

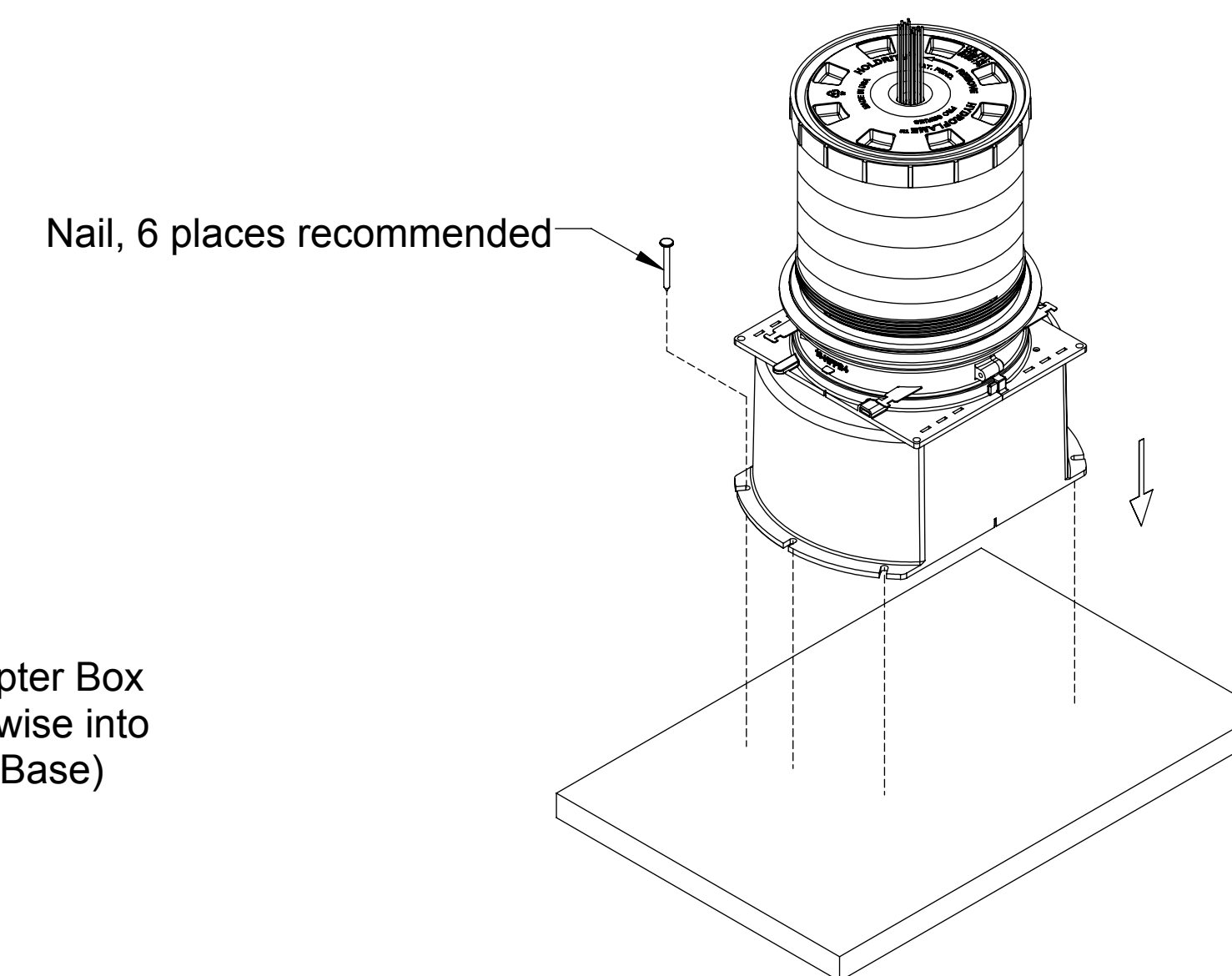

**NAIL TO FORM DECK.**  
(Fig. 6)

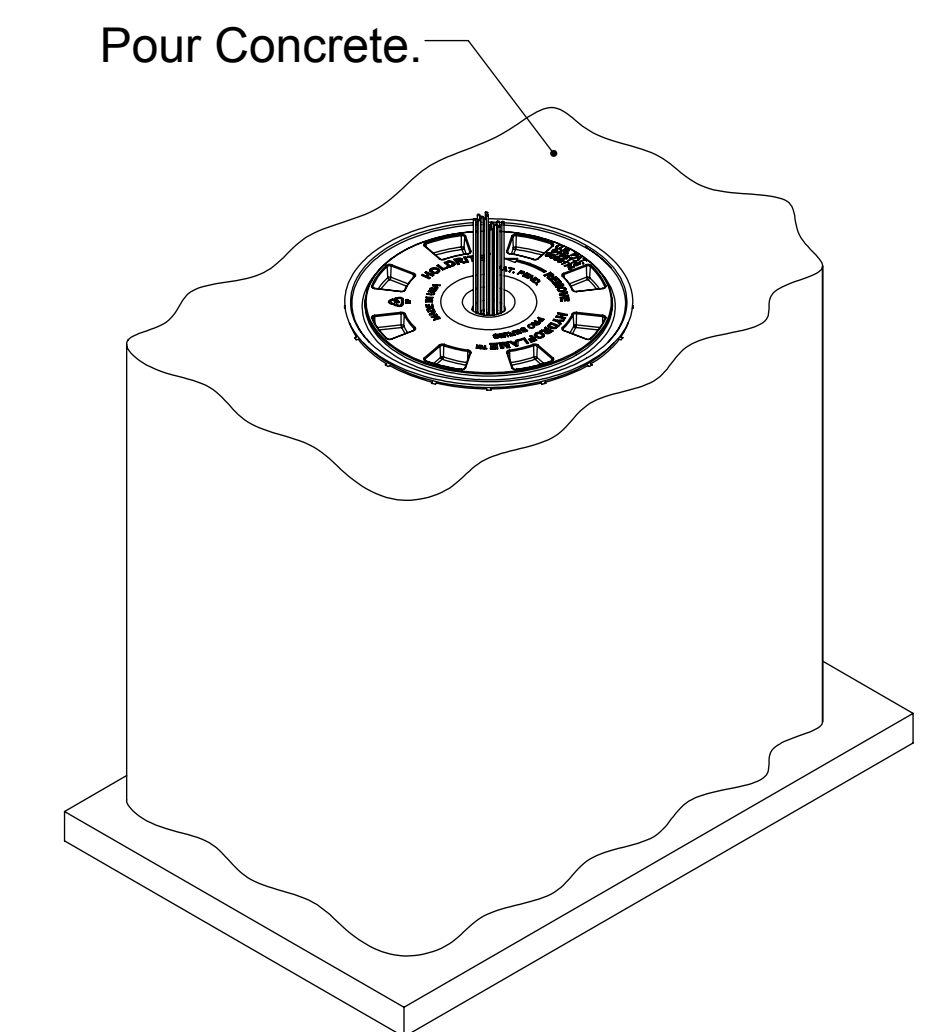

**POUR CONCRETE.**  
(Fig. 7)