

Damper Ultra Low NOx Residential Gas Water Heater

Features

- **Eco-Defender Safety System®**—Designed to be the safest & most reliable flammable vapor ignition resistant system in the industry. Featuring an advanced ScreenLok® technology flame arrestor design, primary and secondary air distribution that reduces NOx generated by combustion, resettable thermal switch, flammable vapor sensor, sight window, and designed to be maintenance-free.
- **Bradford White ICON System®**—Intelligent gas control that eliminates constant burning pilot, saving gas during standby periods (120 VAC). Proprietary algorithms provide tighter temperature differential and consistent water temperature levels up to 160°F (70°C). LED light indicates pilot function or operation status/service required.
- **Vitraglas® Lining with Microban®**—An exclusively engineered enamel formula that provides superior tank protection from the corrosive effects of water; and with Microban® antimicrobial product protection to help prevent the growth of bacteria, mold and mildew on the surface of the tank lining.
- **Hydrojet® Total Performance System**—Sediment reducing device that also increases first hour rating of hot water while minimizing temperature build-up in tank.

Additional Details

- **Automatic Flue Damper**—Reduces standby heat loss, resulting in less gas consumption, higher energy factor ratings, and improved overall efficiency.
—10-foot (3m) Power Cord—Included (120 VAC).
- **Insulation System**—Non-CFC foam covers the tank, reducing heat loss, energy consumption, and improves efficiency and jacket rigidity.
- **Pedestal Base**—Rugged and durable base allows easy transport and positioning while providing corrosion-resistant contact with floor.
- **Water Connections**—3/4" (19mm) NPT factory-installed true dielectric fittings extend water heater life and simplify water line connections.
- **Factory-Installed Heat Traps**—Incorporates a flexible disk that reduces heat loss in piping and prevents noise.
- **Protective Anode Rod**—Provides added protection against corrosion for long-term, trouble-free service.
- **3x4 "Snap Lock" Draft Diverter**—Allows either 3" (76mm) or 4" (102mm) vent connections.
- **T&P Relief Valve**—Installed.
- **Low Restrictive Brass Drain Valve**—Durable tamper proof design.
- **Design Certified by CSA International (formerly AGA/CGA).**
- **Complies with the latest Ultra Low NOx requirement (10 ng/J NOx limit).**



Photo is of URG2D50S6N



6 or 10-Year Limited Tank Warranties / 6-Year Limited Warranty on Component Parts.

For more information on warranty, please visit www.bradfordwhite.com

For products installed in USA, Canada, and Puerto Rico. See complete copy of the warranty included with the heater for limitations.

Microban® antimicrobial product protection helps prevent the growth of bacteria, mold and mildew that may affect the product. The built-in antimicrobial properties do not protect users or others from disease-causing organisms. Microban® is a registered trademark of Microban Products Company.

Damper Ultra Low NOx

Residential Gas Water Heater

SPECIFICATIONS

Natural Gas

These water heaters meet or exceed all or portions of (where applicable) the minimum efficiency requirements of ASHRAE Standard 90.1 (latest edition). C.E.C. Listed. Recovery efficiency ranging up to 78%.

Model Number	Nominal Gal. Capacity		DOE Rated Storage Volume Gal.	BTU/Hr. Input	First Hour Rating Gal.	Uniform Energy Factor	Recovery at 90°F Rise*		Model Number	Nominal Liter Capacity	DOE Rated Storage Volume Liters	kW Input	First Hour Rating Liters	Uniform Energy Factor	Recovery at 50°C Rise* Liters/Hour
	U.S. Gal.	Imp. Gal.					U.S. GPH	Imp. GPH							
URG2D40S6N	40	33	38	38,000	67	0.64	40	33	URG2D40S6N	151	144	11.1	254	0.64	151
URG2D50S6N	50	42	47	40,000	81	0.68	42	35	URG2D50S6N	189	178	11.7	307	0.68	158

Model Number	A Floor to Flue Conn. in.	B Jacket Dia. in.	C Vent Size in.	D Floor to T&P Conn. in.	E Floor to Gas Conn. in.	F Floor to Top of Heater in.	G Floor to Water Conn. in.	H Depth in.	J C/L of Water Conn. in.	M Water Conn. NPT in.	S Gas Conn. Size in.	Approx. Shipping Weight lbs.
URG2D40S6N	57 ⁹ / ₁₆	22	3 or 4	41	11 ¹ / ₂	48 ³ / ₁₆	49 ⁹ / ₁₆	26 ¹ / ₈	11	3/4	1/2	159
URG2D50S6N	65 ⁷ / ₈	22	3 or 4	49 ⁷ / ₈	11 ¹ / ₂	56 ³ / ₄	58 ¹¹ / ₁₆	26	11	3/4	1/2	172

Model Number	A Floor to Flue Conn. mm.	B Jacket Dia. mm.	C Vent Size mm.	D Floor to T&P Conn. mm.	E Floor to Gas Conn. mm.	F Floor to Top of Heater mm.	G Floor to Water Conn. mm.	H Depth mm.	J C/L of Water Conn. mm.	M Water Conn. NPT mm.	S Gas Conn. Size mm.	Approx. Shipping Weight kg.
URG2D40S6N	1456	559	76 or 102	1041	292	1224	1259	664	279	19	13	72
URG2D50S6N	1673	559	76 or 102	1267	292	1441	1491	660	279	19	13	78

Available in Natural Gas only.

For 10 year models, change suffix from "6" to "10".

* Based on manufacturer's rated recovery efficiency.

Uniform Energy Factor and First Hour Rating is based on the latest AHRI directory listings.

120V, 60Hz., 12 Amps.

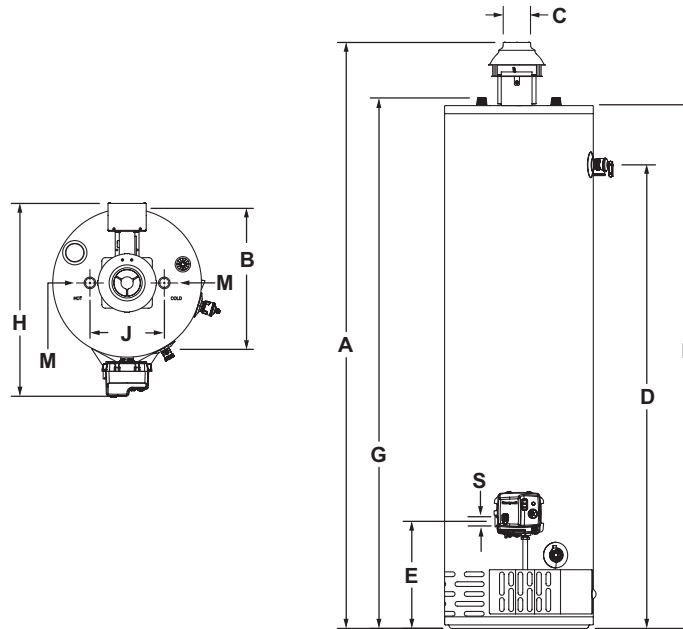

GENERAL:

Meets NAECA Requirements. All gas water heaters are certified at 300 PSI test pressure (2068 kPa) and 150 PSI working pressure (1034 kPa). All water connections are 3/4" NPT (19mm) on 8" (203mm) centers. All Gas Connections are 1/2" (13mm). All models design-certified by CSA International (formerly AGA/CGA) to ANSI standard Z21.10.1.

Suitable for Water (Potable) Heating and Space Heating. Toxic chemicals, such as those used for boiler treatment, shall NEVER be introduced into this system. This unit may NEVER be connected to any existing heating system or component(s) previously used with a non-potable water heating appliance.

Dimensions and specifications subject to change without notice in accordance with our policy of continuous product improvement.



Sales: 800-523-2931

24/7 Technical Support: 800-334-3393 • Email TechServ@bradfordwhite.com

Products made by Bradford White are manufactured in America using the finest materials and components from around the world. ©2024, Bradford White Corporation, USA. All rights reserved.



1118-1224