

**No. 65 - SP COVER**

WT. 79 lbs.

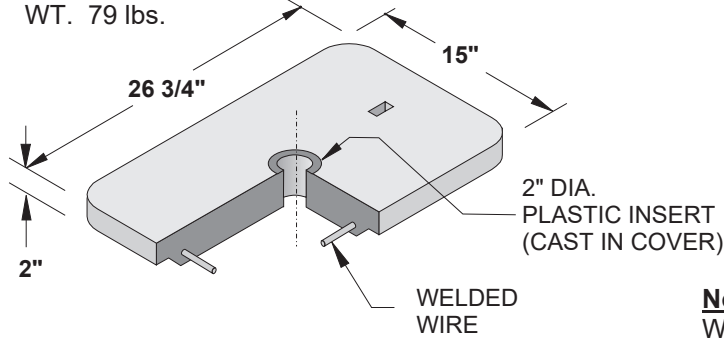

**No. 65 MB - CONCRETE COVER**

WT. 79 lbs.

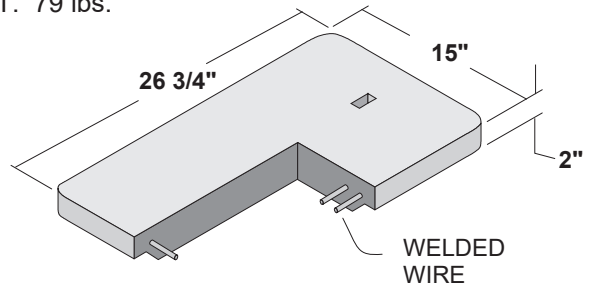

**No. 65 - ST LID (2-ST)**

WT. 9 lbs.

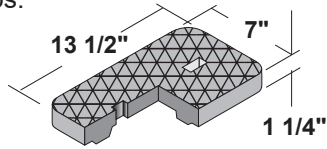

**No. 65 MB - BODY**

WT. 159 lbs.

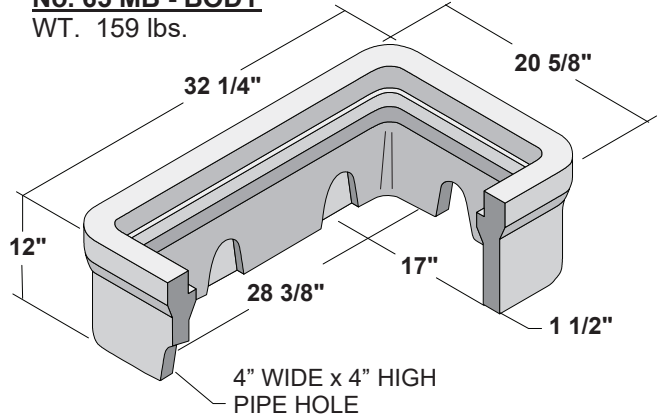

**No. 65 - S LID (2-S)**

WT. 8 lbs.

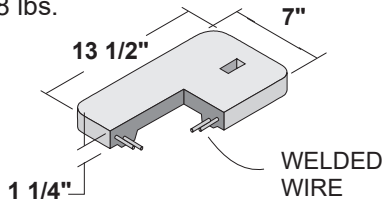

**No. 65 MB - EXTENSION**

WT. 159 lbs.

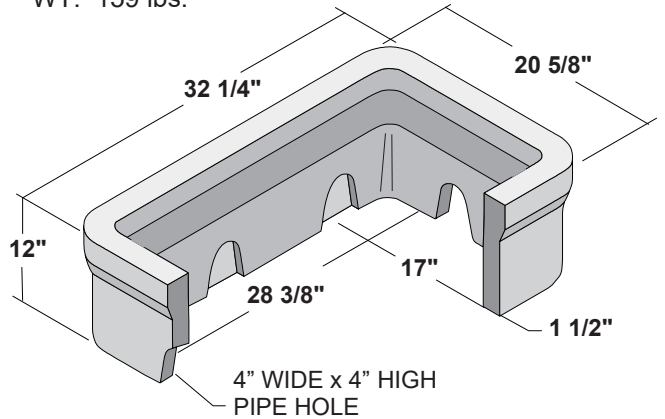

**No. 65 - S COVER**

WT. 63 lbs.

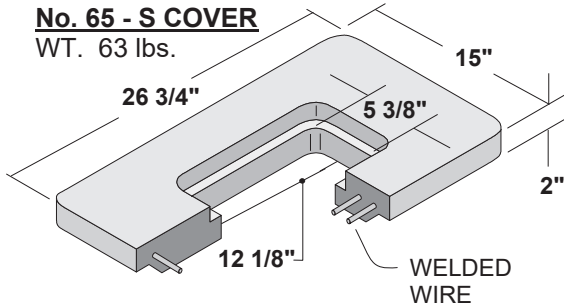

**No. 65 MB - BASE**

WT. 68 lbs.

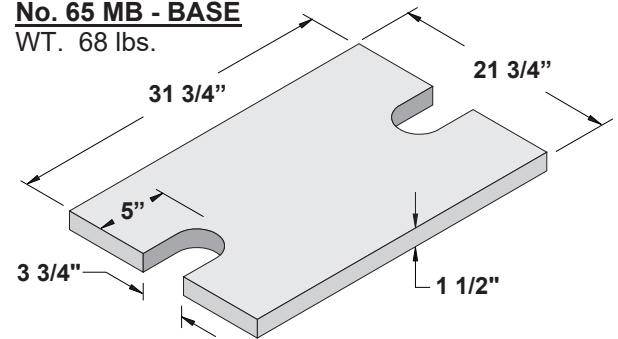

**No. 65 - H COVER WITH C.I. HINGED LID**

WT. 66 lbs.

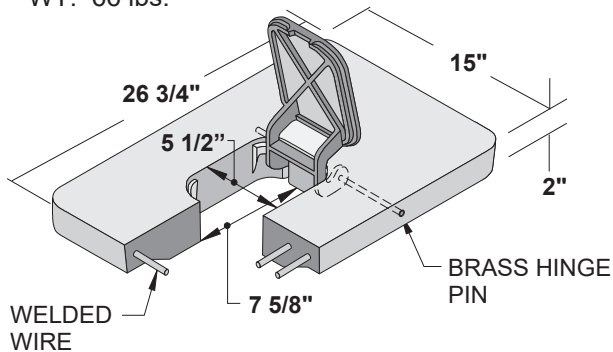

3 - 0 8

17" x 28" METER BOX  
(for 2" WATER METER)

**JENSEN**  
PRECAST EST. 1968

ORG. DWG. DATE  
11-10-95

REV. DWG. DATE  
02-14-20

**BROOKS 65MB**

**No. 65 - T STEEL COVER (SUPERIMPOSED)**

WT. 71 lbs.

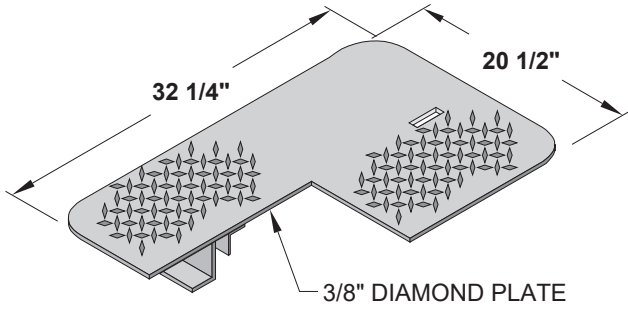

**No. 65 MB - BODY**

WT. 159 lbs.

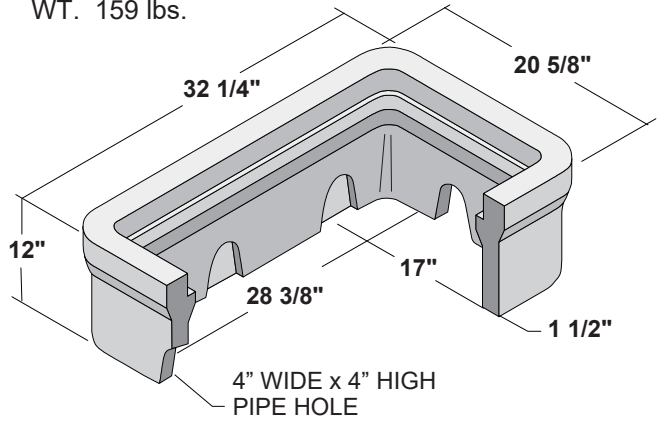

**No. 65 - TR STEEL COVER (SUPERIMPOSED)**

WT. 73 lbs.

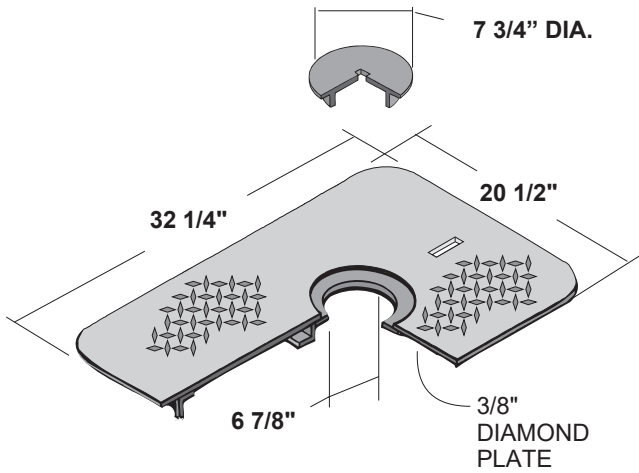

**No. 65 MB - EXTENSION**

WT. 159 lbs.

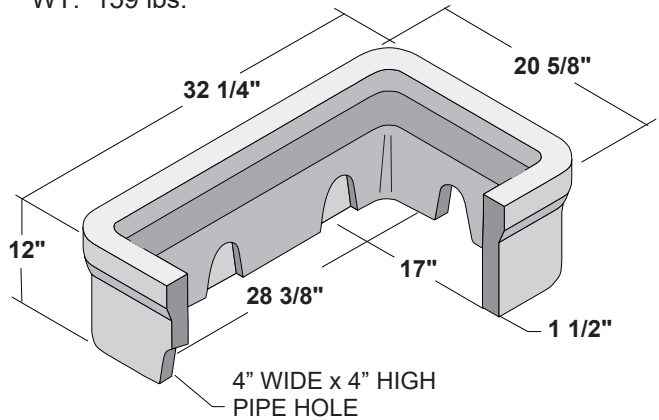

**No. 65 - TF STEEL COVER (FLUSH)**

WT. 68 lbs.

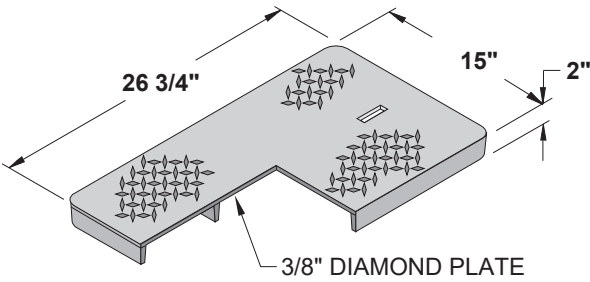

**No. 65 MB - BASE**

WT. 68 lbs.

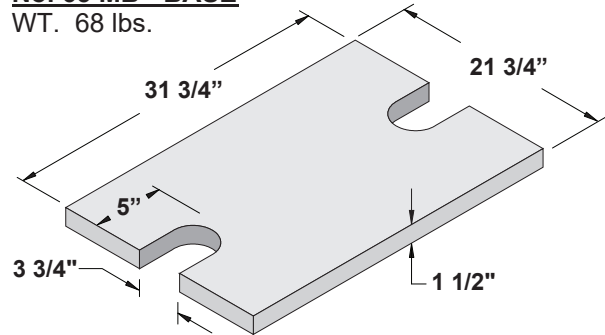

**No. 65 - TFR STEEL COVER (FLUSH)**

WT. 70 lbs.

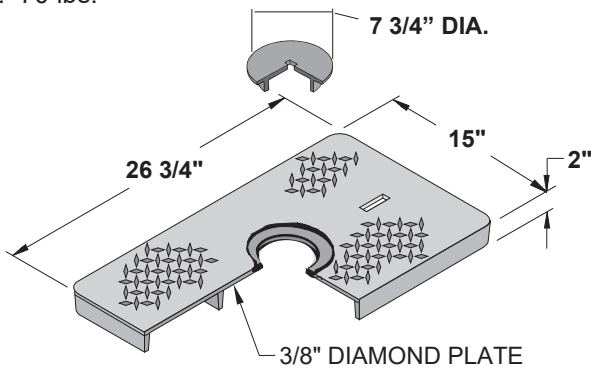

3  
-  
0  
8  
B

<b>17" x 28" METER BOX (for 2" WATER METER)</b>		<b>JENSEN</b> PRECAST  EST. 1968
ORG. DWG. DATE <b>11-10-95</b>	REV. DWG. DATE <b>02-14-20</b>	
<b>BROOKS 65MB</b>		