

Location: _____



BIG
(XL-MI-G-PL)

Big Max® – 75 and 100 GPM
HDPE Grease Interceptors



Specification: MIFAB® Series BIG ____ HDPE rotational molded grease interceptor with flow rating of ____ (indicate) and liquid holding capacity of ____ (indicate). Unit shall include: 3/8" uniform wall thickness, deep seal trap covered by lid, internal air relief by-pass, adjustable lid system, stainless steel calibrated orifice plate (internal flow control), sample port access and 4" no hub inlet and outlet connections. Steel encased composite lid provides a water / gas tight seal and has a minimum of 20,000 lbs. load capacity. The lid is designed in accordance with the loading requirements of AASHTO H20. Interceptor shall be tested and certified to the P.D.I. Standard PDI-G101, CSA B481, A.S.M.E. A112.14.3 and listed with I.A.P.M.O. Big Max grease interceptors are also in compliance with International Plumbing Code (I.P.C.) / I.C.C. by I.A.P.M.O.

Function: Used in restaurants, kitchens, institutional and industrial facilities such as food processing and packaging plants and other types of food processing areas where fat, oil and grease (FOG) drains with the waste water. Typically installed either on or into the floor. Narrow width permits access through doorways and down stairwells. High Density Polyethylene construction ensures a lightweight installation process (two people can move and install it). Regular maintenance is required to keep the interceptor functioning. All Big Max interceptors can withstand a temperature of up to and including 180 degrees Fahrenheit.

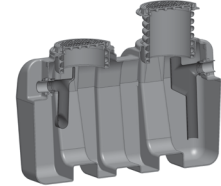
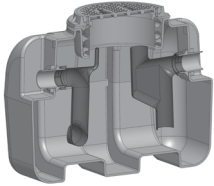

BIG-750

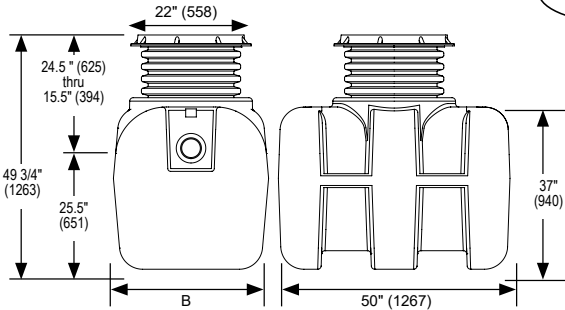

U.S. Patent
9,551,142

BIG-1150

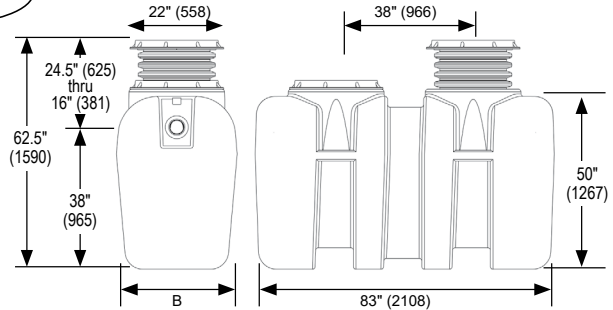

Model No.	Flow Rate (GPM)	Grease Design Capacity	Liquid Holding Capacity (Gallons)	B Width	Shipping Weight (Lbs.)
BIG-750	75	750 Lbs. (105 Gallons)	140	33.50"	150
BIG-1150	100	1,555 Lbs. (216 gallons)	300	33.50"	275

Note: the BIG-750 and BIG-1150 models only meet PDI Standards when installed with an external, vented flow control fitting.

Suffix	Description	Model No.
-AK	Anchor kit (set of four) - for 75 GPM HDPE int.	BIG-750-AK-SET
-AK	Anchor kit (set of four) - for 100 GPM HDPE int.	BIG-1150-AK-SET
-C	Lid extension (specify "C" dimension req.) - for 75 GPM (This is up to a 44" high extension system)	BIG-EXT-44
-C	Lid extension (specify "C" dimension req.) - for 100 GPM (This is up to a 44" high extension system)	BIG-EXT-44 (2 pcs req.)
-C+	Lid extension from 44" to 72" (specify "C" dimension req.) For 75 GPM HDPE Interceptors. Per inch price.	BIG-EXT-72
-C+	Lid extension from 44" to 72" (specify "C" dimension req.) For 100 GPM HDPE Interceptors. Per inch price.	BIG-EXT-72 (2 pcs req.)
-DI	Ductile Iron lid and collar - for 75 GPM HDPE Int.	BIG-PL4
-DI	Ductile Iron lid and collar - for 100 GPM HDPE Int.	BIG-PL4 (2 pcs req.)
-DP	Dosing pump	BIG-DP
-EP	Enzyme port	BIG-EP
-F6	6" no hub inlet + outlet-(for each piece-2 pcs req. per int.)	BIG-PF6
-FL-C	Membrane clamp kit	BIG-FLC
-HLA	High level alarm and float switch (to be installed on site)	BIG-HLA
-LHSI	4" no hub inlet on left hand side	BIG-PF4
-LHSO	4" no hub outlet on left hand side	BIG-PF4
-PDI	PDI plate and external vented flow control fitting to meet PDI Standards)	-PDI
-POK	Remote pump out kit	BIG-POK
-RHSI	4" no hub inlet on right hand side	BIG-PF4
-RHSO	4" no hub outlet on right hand side	BIG-PF4
-RPO	4" Remote pump outlet connections on top of interceptor - specify location and number required	BIG-RPO
-SB	Sediment bucket - for 75 GPM HDPE Int.	BIG-750-PSB
-SB	Sediment bucket - for 100 GPM HDPE Int.	BIG-1150-PSB
-SP	External Sampling port - inline, high connections	BIG-SP
-SP-L	External Sampling port - inline, low connections	BIG-SP-L
-SP-OFF	External Sampling port - offset	BIG-SP-OFF
-T	Female threaded connections (for each piece-2 pcs req. per int.)	BIG-PF(*)-FT(*) (*) Specify Conn. Size

CALIFORNIA PROPOSITION 65 WARNING. This product contains chemicals known to the State of California to cause cancer and birth defects or other reproductive harm.

Job Name: _____ Page No: _____
 Section No: _____ Contractor: _____
 Schedule No: _____ Purchase Order No: _____