

FIGURE HPA BUTTERFLY VALVES



HIGH-PERFORMANCE BUTTERFLY VALVE

FEATURES

- Class 150 and 300 wafer or lug style
- Carbon steel (WCB) and stainless steel (CF8M) body
- Available in fire safe configuration (WCB only)
- Double offset design with conical angled disc
- Bidirectional bubble-tight shutoff
- Lug-style ASME rated for dead-end service in both directions
- Standard HyperSeat® rated to 500°F
- Suitable for saturated steam service to 150 psi
- ISO 5211 mounting flange
- Blowout-proof stem
- Integral cast disc over-travel stop
- Live loaded packing adjustable without actuator removal
- Manufactured in ISO 9001 Facility

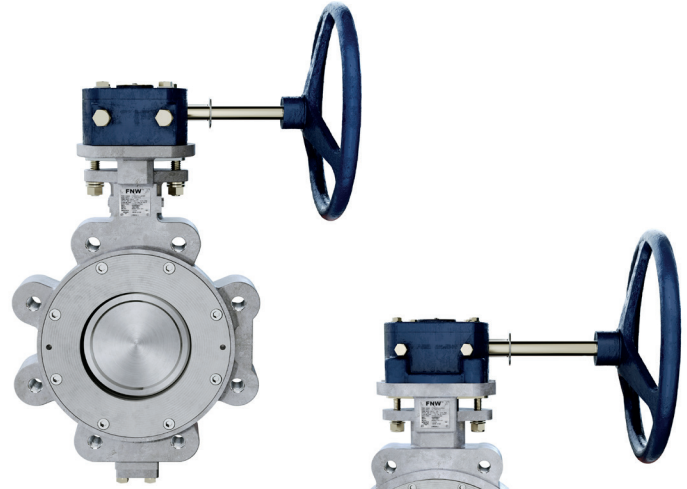

PRODUCT SPECIFICATIONS

Standards:

- Design: API 609
- Mounting Pad: ISO 5211
- End Flange: ASME B16.5
- Face to Face: API 609
- Pressure/Temp Rating: ASME B16.34
- Shell/Seat Test: API 598
- Emissions Compliance: ISO 15848-1
- NSF 61 and NSF 372 (UL) Certified
Applies only to SS construction thru 24"

Options

FNW offers many options and modifications for valves. These include, but are not limited to: Actuation including chain wheels, square drive nuts, worm-gear operators and pneumatic and electric operators. Also available are various control accessories, stem extensions and custom mounting hardware. Contact FNW with your specific application needs.

** Vacuum measurements are often made in inches of mercury below atmospheric pressure. The values calculated here assume standard atmospheric pressure of 29.92 inches of mercury.

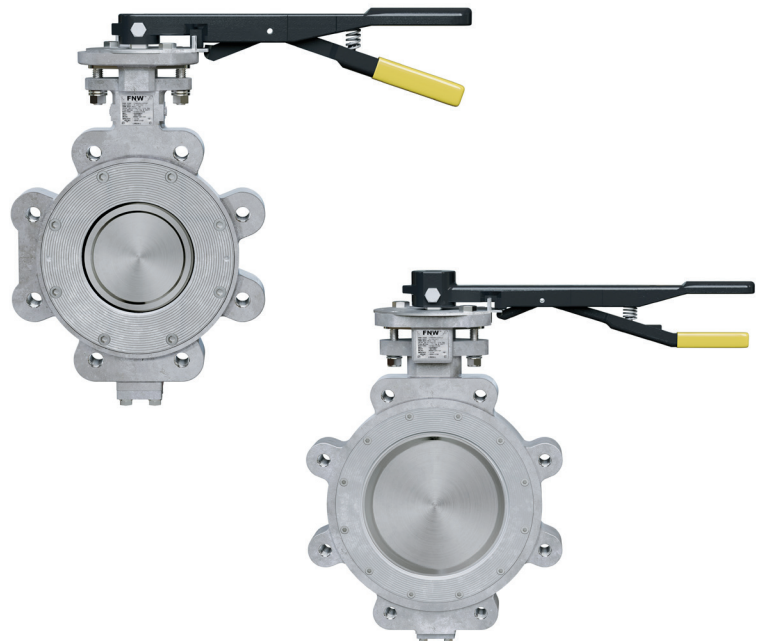
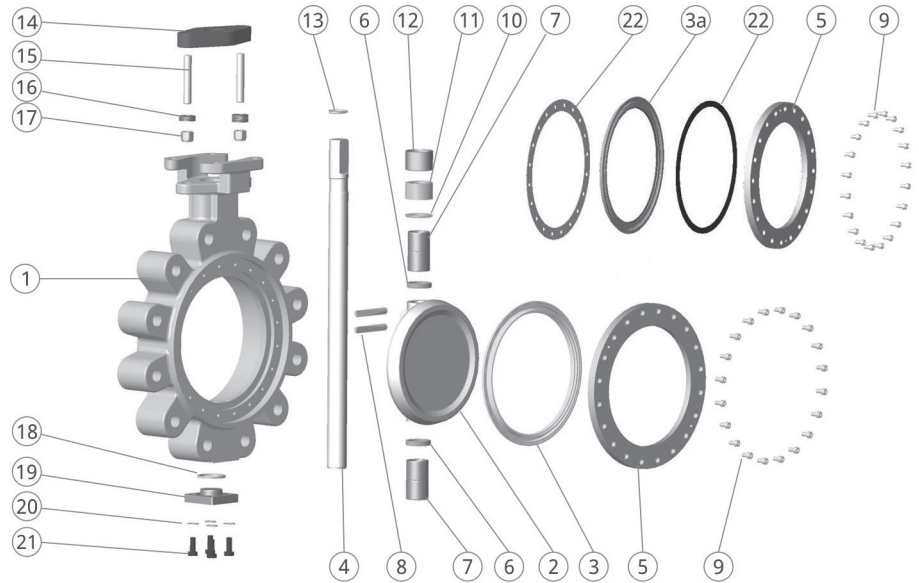

FIGURE HPA BUTTERFLY VALVES



HIGH-PERFORMANCE BUTTERFLY VALVE

WAFER AND LUG (2"-12")



STANDARD MATERIALS OF CONSTRUCTION

Item	Component	WCB	CF8M
1	Body	ASTM A216 WCB	ASTM A351 CF8M
2	Disc	ASTM A351 CF8M	ASTM A351 CF8M
3	Seat (Soft)	HyperSeat	HyperSeat
3a	Seat (Fire Seat)	ASTM A240 SS 316 + HyperSeat	ASTM A240 SS 316 + HyperSeat
4	Stem (for Soft Seat)	ASTM A564 Type 630 (17-4PH)	ASTM A479 SS316 LEVEL 2
	Stem (for Fire Safe)	ASTM A564 Type 630 (17-4PH)	ASTM A564 Type 630 (17-4PH)
5	Seat Retaining Ring	Carbon Steel	ATM A240 SS316
6	Disc Spacer	ASTM A479 SS316	ASTM A479 SS316
7	Bearing (Soft Seat)	Bear-X	Bear-X
	Bearing (Fire Safe)	Fireproof FFP-D1	Fireproof FFP-D1
8	Wedge Key	ASTM A564 Type 630 (17-4PH)	ASTM A564 Type 630 (17-4PH)
9	Retainer Screw	ISO 3506 A4-70	ISO 3506 A4-70
10	Packing Spacer	ASTM A479 SS316	ASTM A479 SS316

Item	Component	WCB	CF8M
11	Gland Packing	PTFE (Chevron V-Ring)	PTFE (Chevron V-Ring)
12	Gland	ASTM A479 SS316	ASTM A479 SS316
13	Stem Retainer	ASTM A313 SS302	ASTM A313 SS302
14	Gland Flange	ASTM A105/ ASTM A216 WCB/ Carbon Steel	ASTM A240 SS316/ ASTM A351 CF8M/ASTM A182 F316
15	Stud	ASTM A193 Gr B8M	ASTM A193 Gr B8M
16	Belleville Spring	ASTM A666 SS 304	ASTM A666 SS 304
17	Hex Nut	ASTM A194 Gr 8M	ASTM A194 Gr 8M
18	Cover Gasket	PTFE	PTFE
19	Bottom Cover	Carbon Steel	ASTM A240 SS316
20	Spring Washer	ASTM A580 SS304	ASTM A580 SS304
21	Hex Head Bolt	ISO 3506 A4 -70	ISO 3506 A4 -70
22	Seat Gasket (Fire Safe)	Graphite	Graphite

FIGURE HPA BUTTERFLY VALVES



HIGH-PERFORMANCE BUTTERFLY VALVE

WAFER AND LUG (14"-36")

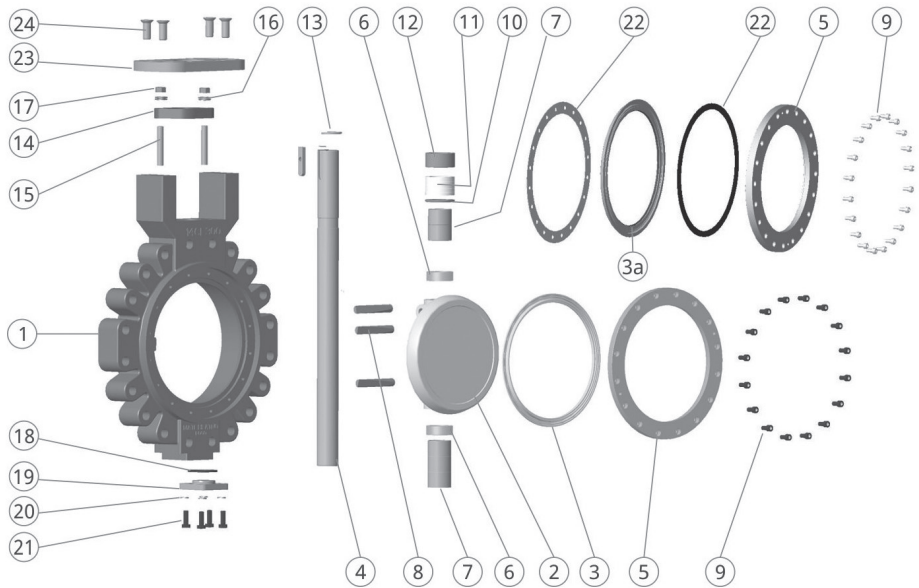

STANDARD MATERIALS OF CONSTRUCTION

Item	Component	WCB	CF8M
1	Body	ASTM A216 WCB	ASTM A351 CF8M
2	Disc	ASTM A351 CF8M	ASTM A351 CF8M
3	Seat (Soft)	HyperSeat	HyperSeat
4	Stem (for Soft Seat)	ASTM A564 Type 630 (17-4PH)	ASTM A564 Type 630 (17-4PH)
	Stem (for Fire Safe)	ASTM A564 Type 630 (17-4PH)	ASTM A564 Type 630 (17-4PH)
5	Seat Retaining Ring	Carbon Steel	ATM A240 SS316
6	Disc Spacer	ASTM A479 SS316	ASTM A479 SS316
7	Bearing (Soft Seat)	Bear-X	Bear-X
	Bearing (Fire Safe)	Fireproof FFP-D1	Fireproof FFP-D1
8	Wedge Key	ASTM A564 Type 630 (17-4PH)	ASTM A564 Type 630 (17-4PH)
9	Retainer Screw	ISO 3506 A4-70	ISO 3506 A4-70
10	Packing Spacer	ASTM A479 SS316	ASTM A479 SS316
11	Gland Packing	PTFE (Chevron V-ring)	PTFE (Chevron V-ring)

Item	Component	WCB	CF8M
12	Gland	ASTM A479 SS316	ASTM A479 SS316
13	Stem Retainer	ASTM A313 SS302	ASTM A313 SS302
14	Gland Flange	ASTM A105/ ASTM A216 WCB/ Carbon Steel	ASTM A 240 SS316/ ASTM A351 CF8M/ASTM A182 F316
15	Stud	ASTM A193 Gr B8M	ASTM A193 Gr B8M
16	Belleville Spring	ASTM A666 SS 304	ASTM A666 SS 304
17	Hex Nut	ASTM A194 Gr 8M	ASTM A194 Gr 8M
18	Cover Gasket	PTFE	PTFE
19	Bottom Cover	Carbon steel	ASTM A240 SS316
20	Spring Washer	ASTM A580 SS304	ASTM A580 SS304
21	Hex Head Bolt	ISO 3506 A4 -70	ISO 3506 A4 -70
22	Seat Gasket (Fire Safe)	Graphite	Graphite
23	Mounting plate (Iso Plate)	Carbon steel	ASTM A240 SS316
24	Counter sunk screw	ISO 3506 A4 -70	ISO 3506 A4 -70

FIGURE HPA BUTTERFLY VALVES



HIGH-PERFORMANCE BUTTERFLY VALVE

DIMENSIONS AND WEIGHTS WAFER AND LUG

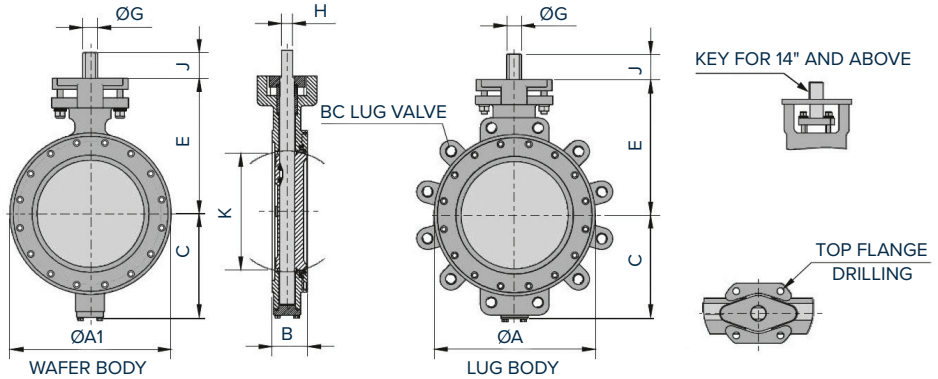

ASME CLASS 150 DIMENSIONS (INCHES)

Valve Size	Inch	DN	ØA	ØA1	*B	C	E	Top Flanged Drilling			ØG	H	J	KEY SIZE	K	Lug Drilling D			App. Weight (lbs)	
								BC	No. of Holes	Hole Dia.						BC	No. of Holes	Tapping/UNC/UN2B	Wafer	Lug
2	50	3.82	3.82	1.69	2.68	4.92	2.76	4	0.39	0.55	0.39	1.26	-	1.57	4.75	4	5/8-11	7.3	9.5	
2-1/2	65	4.13	4.13	1.81	2.95	5.75	2.76	4	0.39	0.63	0.43	1.26	-	2.19	5.50	4	5/8-11	8.8	11.0	
3	80	5.47	5.47	1.89	4.25	5.91	2.76	4	0.39	0.63	0.43	1.26	-	2.69	6.00	4	5/8-11	13.9	15.4	
4	100	6.69	6.69	2.13	4.84	6.77	2.76	4	0.39	0.63	0.43	1.26	-	3.53	7.50	8	5/8-11	18.3	26.5	
5	125	7.32	7.32	2.24	4.72	7.40	2.76/4.02	4	0.39/0.43	0.75	0.51	1.26	-	4.36	8.50	8	3/4-10	19.8	29.5	
6	150	8.50	8.50	2.24	5.83	8.07	2.76/4.02	4	0.39/0.47	0.75	0.51	1.26	-	5.46	9.50	8	3/4-10	30.9	35.3	
8	200	10.59	10.59	2.52	6.81	9.45	4.92	4	0.55	0.87	0.63	1.26	-	7.21	11.75	8	3/4-10	48.5	63.9	
10	250	12.76	12.76	2.80	8.54	10.71	4.92	4	0.55	1.18	0.87	2.01	-	9.16	14.25	12	7/8-9	70.5	94.9	
12	300	15.00	14.88	3.19	9.80	12.20	4.92	4	0.55	1.38	0.94	2.01	-	10.93	17.00	12	7/8-9	106.9	147.7	
14	350	16.26	16.26	3.62	11.18	15.94	4.92/5.51	4	0.55/0.71	1.57	-	2.01	0.47 x 0.31	12.12	18.75	12	1-8	185.2	238.1	
16	400	18.50	18.50	4.02	12.40	17.95	5.51/6.50	4	0.71/0.87	1.97	-	2.52	0.47 x 0.31	13.94	21.26	16	1-8	260.1	328.5	
18	450	21.02	21.02	4.49	13.35	19.33	5.51/6.50	4	0.71/0.87	2.17	-	2.52	0.63 x 0.39	15.94	22.75	16	1-1/8-8	339.5	390.2	
20	500	22.99	22.99	5.00	14.76	21.10	6.50	4	0.87	2.36	-	4.02	0.71 x 0.43	17.57	25.00	20	1-1/8-8	449.7	566.6	
24	600	27.36	27.36	6.06	17.24	24.96	6.50/10	8	0.87/0.71	2.76	-	4.02	0.79 x 0.47	20.97	29.50	20	1-1/4-8	776.0	892.9	
26	650	29.49	29.49	6.50	18.70	26.93	10.00	8	0.71	3	-	4.02	0.75 x 0.75	23.82	31.75	24	1-1/4-8	1135.0	1365.0	
28	700	31.50	30.00	6.50	19.69	28.74	10/11.73	8	0.71/0.87	3	-	4.02	0.75 x 0.75	24.61	34.00	28	1-1/8-8	1135.4	1366.9	
30	750	33.74	33.74	7.48	21.26	28.35	10/11.73	8	0.71/0.87	3.50	-	4.02	0.88 x 0.63	25.59	36.00	28	1-1/4-8	1140.0	1580.7	
32	800	35.98	34.02	7.48	22.05	30.75	11.73	8	0.87	3.50	-	4.02	0.88 x 0.63	27.44	38.50	28	1-1/2-8	1450.6	1873.9	
36	900	40.24	37.99	7.99	25.59	33.86	11.73	8	0.87	4.00	-	5.27	100 x 0.75	31.00	42.75	32	1-1/2-8	1907.0	2641.1	

ASME CLASS 300 DIMENSIONS (INCHES)

2	50	4.02	4.02	1.69	3.39	5.24	2.76	4	0.39	0.55	0.39	1.26	-	1.49	5.00	8	5/8-11	7.7	11.0
2-1/2	65	4.13	4.13	1.81	3.86	5.75	2.76	4	0.39	0.63	0.43	1.26	-	1.99	5.87	8	3/4-10	8.8	12.1
3	80	5.20	5.47	1.89	4.29	6.22	2.76	4	0.39	0.63	0.43	1.26	-	2.67	6.63	8	3/4-10	13.4	18.7
4	100	6.69	6.69	2.13	4.84	6.77	2.76	4	0.39	0.63	0.43	1.26	-	3.55	7.87	8	3/4-10	19.0	26.5
5	125	7.32	7.32	2.32	5.47	7.99	2.76/4.02	4	0.39/0.47	0.75	0.51	1.26	-	4.17	9.25	8	3/4-10	20.3	36.8
6	150	8.50	8.50	2.32	6.42	8.66	2.76/4.02	4	0.39/0.47	0.87	0.63	1.26	-	5.42	10.63	12	3/4-10	39.7	55.1
8	200	10.63	10.63	2.87	7.87	10.94	4.92	4	0.55	1.18	0.87	2.01	-	7.16	13.00	12	7/8-9	70.5	94.8
10	250	12.83	12.83	3.27	9.06	11.81	4.92	4	0.55	1.38	0.94	2.01	-	8.87	15.25	16	1-8	88.6	134.5
12	300	15.00	15.00	3.62	10.51	13.43	5.51/6.50	4	0.71/0.87	1.57	1.14	2.01	-	10.75	17.75	16	1-1/8-8	172.4	220.5
14	350	16.26	16.26	4.61	12.40	17.99	5.51/6.50	4	0.71/0.87	2.17	-	2.52	0.63 x 0.39	11.38	20.25	20	1-1/8-8	286.6	381.4
16	400	18.50	18.50	5.24	14.37	20.79	6.50	4	0.87	2.17	-	2.52	0.63 x 0.39	13.37	22.50	20	1-1/4-8	392.4	493.8
18	450	20.98	20.98	5.87	15.08	23.27	10.00	8	0.71	2.76	-	4.02	0.79 x 0.47	14.99	24.75	24	1-1/4-8	485.0	848.8
20	500	22.99	22.99	6.26	17.17	23.70	10/11.73	8	0.71/0.87	3.15	-	4.02	0.87 x 0.55	16.07	27.00	24	1-1/4-8	877.4	988.7
24	600	27.24	27.24	7.13	19.84	31.30	11.73	8	0.87	3.94	-	5.28	1.10 x 0.63	19.71	32.00	24	1-1/2-8	1157.4	1862.9

Face to Face dimension "B" conforms to API 609 Category B up to 24" CL 150 and CL 300.

FIGURE HPA BUTTERFLY VALVES



HIGH-PERFORMANCE BUTTERFLY VALVE

LEVER DIMENSIONS

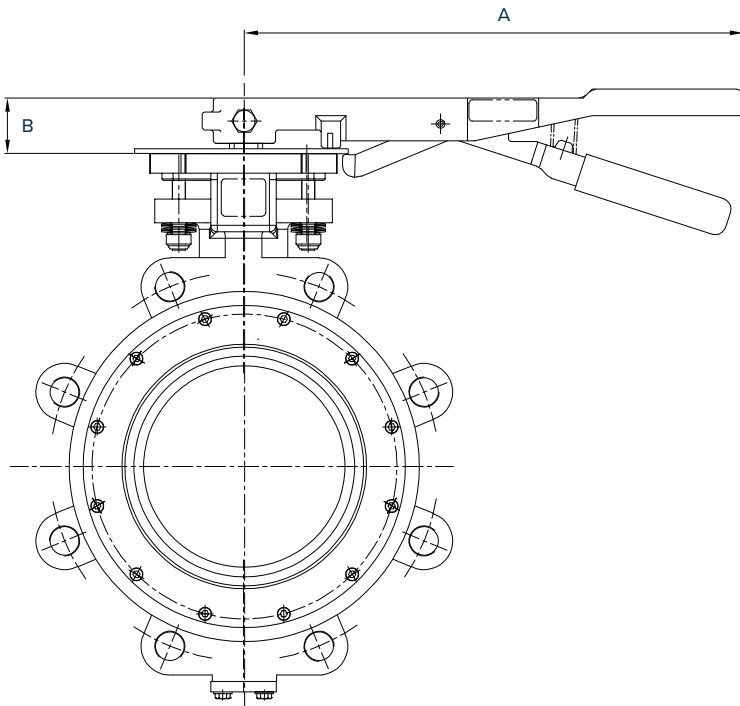

ASME CLASS 150 WAFER AND LUG

Valve Size (Inches)	A	B
2	11.02	1.12
2-1/2	11.02	1.12
3	11.02	1.12
4	11.02	1.12
5	15.75	1.84
6	15.75	1.84

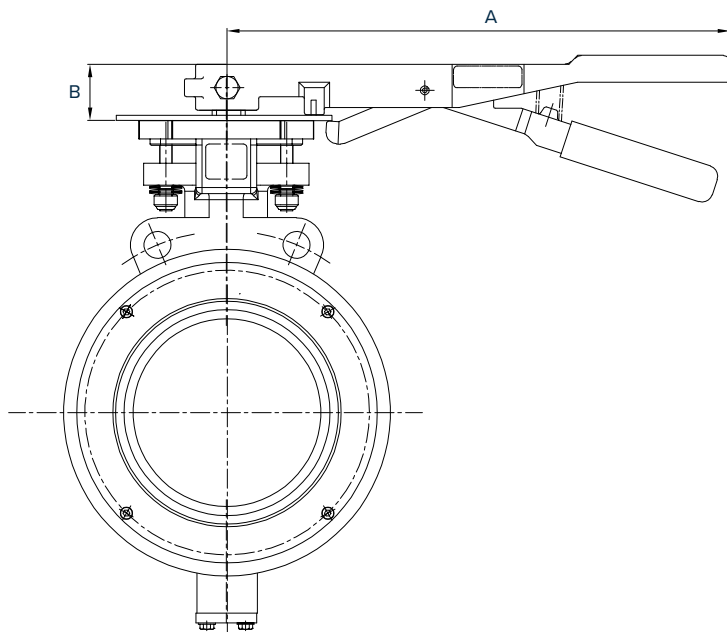

ASME CLASS 300 WAFER AND LUG

Valve Size (Inches)	A	B
2	11.02	1.26
2-1/2	11.02	1.26
3	11.02	1.26
4	15.75	1.85

FIGURE HPA BUTTERFLY VALVES



HIGH-PERFORMANCE BUTTERFLY VALVE

ASME CLASS 150

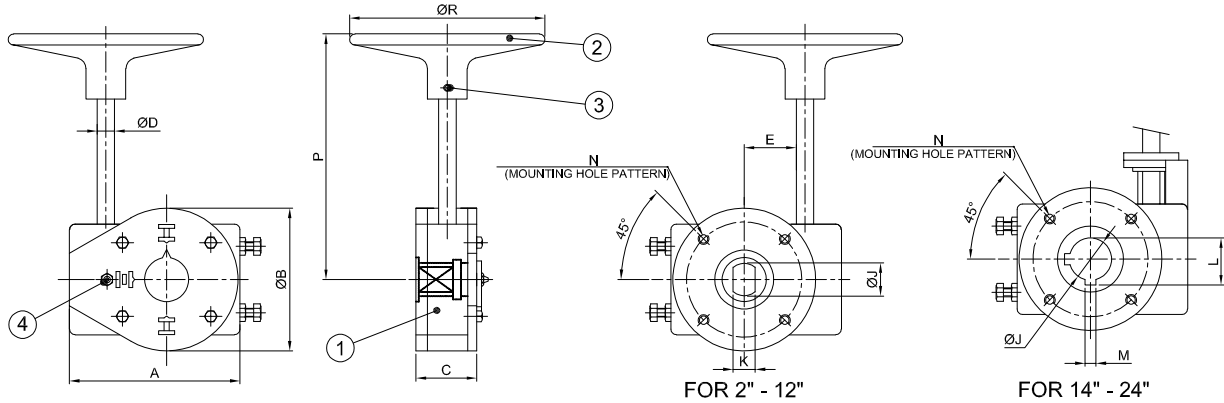

PARTS LIST

No.	Part Name	Material Specification	Qty.
1	Gear Operator	As per assembly	01
1a	Gear Housing	ASTM A48 30A	
1b	Gear Housing Cover	ASTM A48 30A	
1c	Worm Wheel	ASTM A536 70-50-05	
1d	Worm	SAE 1040 / SAE 4140	
1e	Input Shaft	SAE 1040 / SAE 4140	
2	Conical Hand Wheel	ASTM A106 GR. B	01
3	Spring Dowel Pin	Spring Steel	01
4	Grease Nipple	Carbon Steel	01

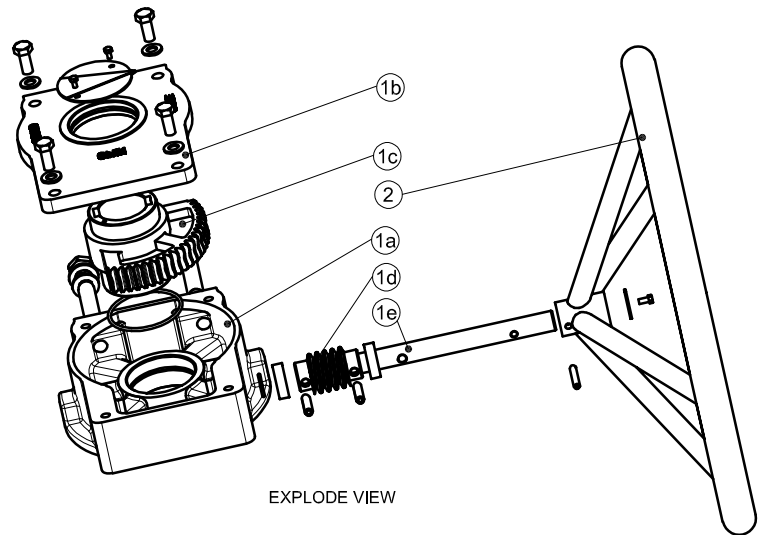

DIMENSIONS (INCHES)

Valve Size	Ratio	Model	Gear Output Torque (lbs-in)	Mech. Adv.	A	ØB	C	E	ØD	ØJ	K	L	M	N (Mounting Holes Pattern)				P	ØR	WT. (lbs)
														BC	Holes	Threading	Depth			
2-DN 6	31:1	EG-250	2212	8	4.01	3.5	2.01	1.73	0.5	0.98	0.75	-	-	2.76	04	5/16"-18 UNC	0.47	7.08	7.87	5.3
8-10	40:1	EG-700	6195	10	5.60	4.97	2.91	2.60	0.79	1.18	0.87	-	-	4.92	04	1/2"-13 UNC	0.71	11.1	11.81	15.4
12	40:1	EG-700	6195	10	5.60	4.97	2.91	2.60	0.79	1.38	0.94	-	-	4.92	04	1/2"-13 UNC	0.71	11.1	11.81	15.4
14	65:1	EG1K5	13276	14	7.24	6.30	3.13	3.19	0.79	1.57	-	1.70	0.47	5.51	04	5/8"-11 UNC	0.94	12.28	19.69	26.5
16	60:1	EG2K	17700	16	8.42	6.93	3.77	3.66	0.87	1.97	-	2.14	0.47	6.5	04	3/4"-10 UNC	1.02	16.73	19.69	33.1
18	80:1	EG3K	26552	22	9.26	9.29	4.33	4.72	0.98	2.17	-	2.33	0.63	6.5	04	3/4"-10 UNC	1.18	14.13	19.69	55.1
20	80:1	EG3K	26552	22	9.26	9.29	4.33	4.72	0.98	2.36	-	2.54	0.71	6.5	04	3/4"-10 UNC	1.02	19.45	17.72	55.1
24	220:1	EG4K5	39828	50	9.25	11.81	4.33	7.02	0.79	2.75	-	2.95	0.79	10	08	5/8"-11 UNC	0.94	16.18	19.69	88.2

FIGURE HPA BUTTERFLY VALVES



HIGH-PERFORMANCE BUTTERFLY VALVE

ASME CLASS 300

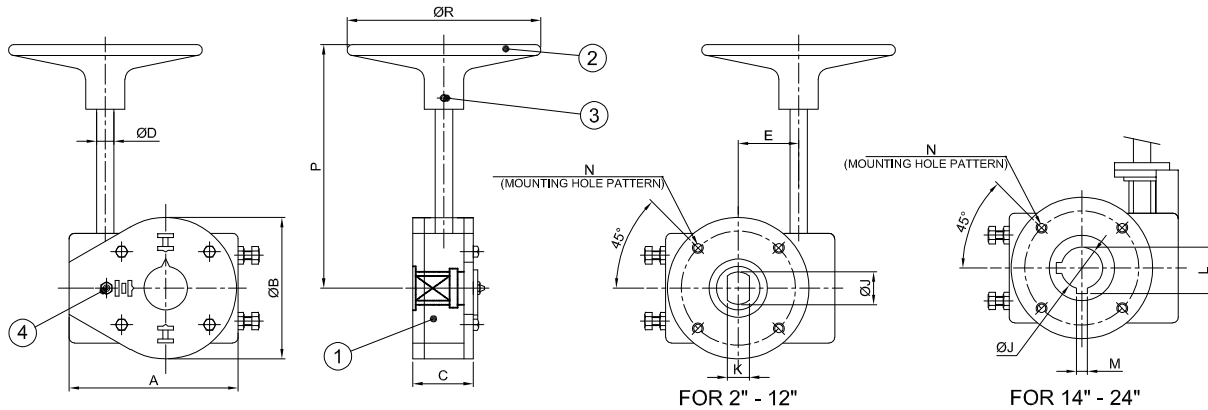

PARTS LIST

No.	Part Name	Material Specification	Qty.
1	Gear Operator	As per assembly	01
1a	Gear Housing	ASTM A48 30A	
1b	Gear Housing Cover	ASTM A48 30A	
1c	Worm Wheel	ASTM A536 70-50-05	
1d	Worm	SAE 1040 / SAE 4140	
1e	Input Shaft	SAE 1040 / SAE 4140	
2	Conical Hand Wheel	ASTM A106 GR. B	01
3	Spring Dowel Pin	Spring Steel	01
4	Grease Nipple	Carbon Steel	01

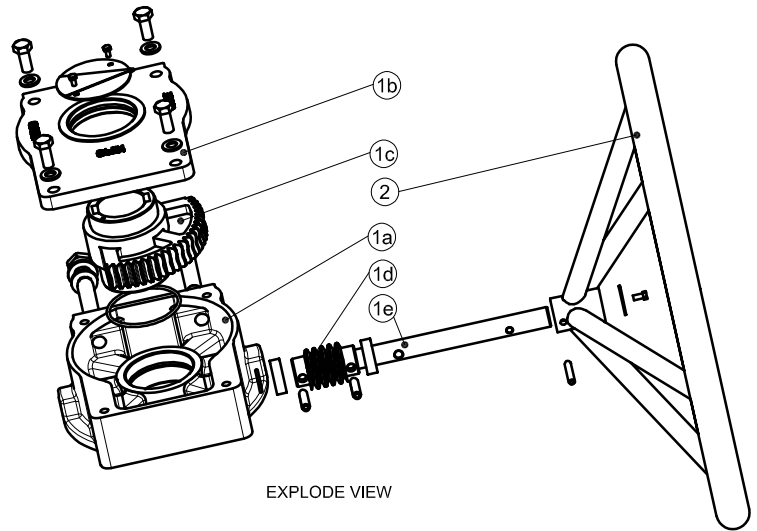

DIMENSIONS (INCHES)

Valve Size	Ratio	Model	Gear Output Torque (lbs-in)	Mech. Adv.	A	ØB	C	E	ØD	ØJ	K	L	M	N (Mounting Holes Pattern)				P	ØR	WT. (lbs)
														BC	Holes	Threading	Depth			
2-DN 4	31:1	EG-250	2212	8	4.01	3.5	2.01	1.73	0.5	0.98	0.75	-	-	2.76	04	5/16"-18 UNC	0.47	7.08	7.87	5.3
5	40:1	EG-500	4425	10	5.35	4.25	2.54	2.13	0.59	0.75	0.51	-	-	4.02	04	3/6"-16 UNC	0.59	9.84	9.84	11.02
6	40:1	EG-500	4425	10	5.35	4.25	2.54	2.13	0.59	0.87	0.63	-	-	4.02	04	3/8"-16 UNC	0.59	9.84	9.84	11.02
8	44:1	EG 1K	8851	12	7.08	5.59	3.34	2.87	0.79	1.18	0.87	-	-	4.92	04	1/2"-13 UNC	0.71	13.19	17.72	22.04
10	65:1	EG1K5	13276	14	7.24	6.30	3.12	3.19	0.79	1.38	0.94	-	-	4.92	04	1/2"-13 UNC	0.71	11.97	17.72	26.45
12	60:1	EG2K	17701	16	8.43	6.93	3.78	3.66	0.87	1.57	1.14	-	-	6.5	04	3/4"-10 UNC	1.02	16.73	19.69	33.1
14	220:1	EG4K5	39828	50	9.25	9.29	4.33	7.03	0.79	2.17	-	2.33	0.63	6.5	04	3/4"-10 UNC	1.18	15.59	23.62	79.36
16	220:1	EG4K5	39828	50	9.25	9.29	4.33	7.01	0.79	2.17	-	2.33	0.63	6.5	04	3/4"-10 UNC	1.18	16.73	23.62	79.3
18	292:1	EG 6K5	57530	65	10.43	11.81	4.47	7.74	0.79	2.76	-	2.95	0.79	10	08	5/8"-11 UNC	0.94	16.73	23.62	103.6
20	300:1	EG 10K	88507.5	75	13.23	14.84	5.98	9.52	0.79	3.15	-	3.36	0.87	10	08	5/8"-11 UNC	0.94	17.83	23.62	181
24	300:1	EG 10K	88507.5	75	13.23	14.84	5.98	9.52	0.79	3.94	-	4.19	1.10	11.73	08	3/4"-10 UNC	0.94	17.83	23.62	181

FIGURE HPA BUTTERFLY VALVES



HIGH-PERFORMANCE BUTTERFLY VALVE

DOUBLE OFFSET DESIGN

The valve is designed with two offsets. The first offset is between the seat sealing surface and the centerline of the valve stem, putting the stem behind the sealing surface. Since the stem does not penetrate the sealing surface, there is a complete, uninterrupted 360° seat seal. The second offset is between the centerline of the valve stem and the centerline of the valve port. This double offset creates an eccentric seating action that reduces seat wear and torque. The disc cams into the seat for a bubble-tight shutoff. The cam action is improved by the conical angle of the valve disc.

DOUBLE OFFSET

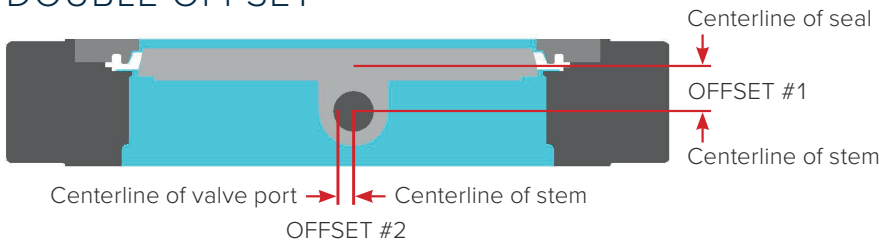

CAM ACTION

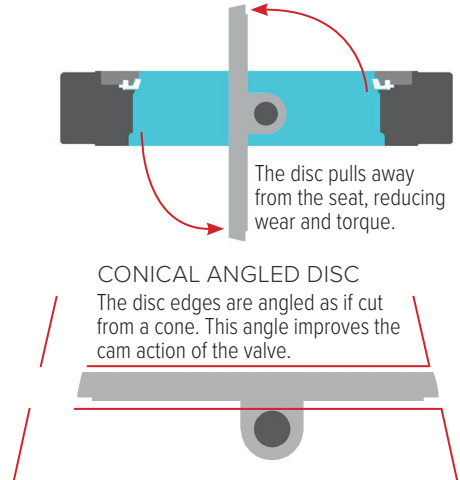

HyperSeat is an engineered fluorocarbon polymer that is rated for 500° F at 285 psi. Its superior ability to handle aggressive fluids at high pressures is recommended for extended service in hostile environments involving chemical, thermal and mechanical stress. HyperSeat has excellent thermal stability and is ideal for steam, hot gases and a variety of process chemicals where service can also be subject to pressure cycling.

PRESSURE TEMPERATURE RATINGS

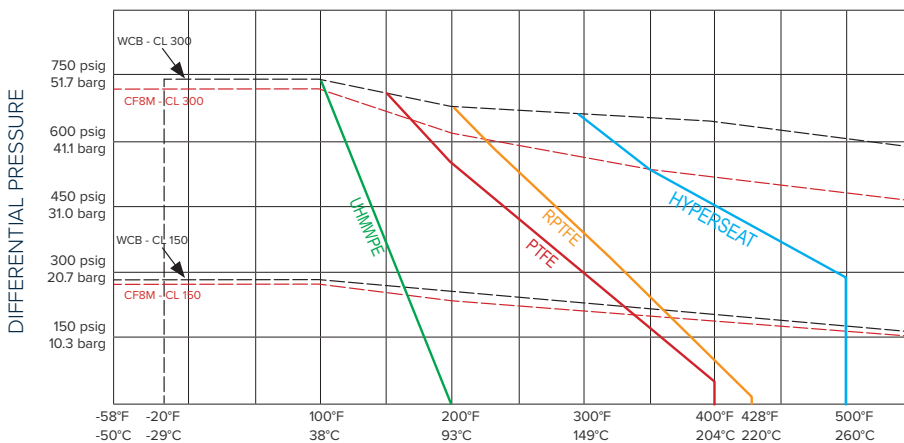

TEMPERATURE LIMITS

		Lower Limit	Upper Limit
		Deg F	Deg F
Body	WCB	-20	800
	CF8M	-320	1000
Seat	PTFE	-58	400
	RPTFE	-58	428
	HYPERSEAT	-58	500
	UHMWPE	-20	200

Pressure-temperature rating shall be lesser of the shell or seat rating

FIGURE HPA BUTTERFLY VALVES



HIGH-PERFORMANCE BUTTERFLY VALVE

Cv (FLOW COEFFICIENTS)

Cv values indicated below are obtained from CFD analysis. As the calculations are software based, accuracy is +/- 10%.

ASME CLASS 150 (INCHES)

Disc Position	Value Size 150#													
Degrees	2	2-1/2	3	4	5	6	8	10	12	14	16	18	20	24
10	2	3	4	5	5	6	25	55	82	130	234	268	291	694
20	10	12	18	30	46	85	182	350	508	552	905	1044	1326	2250
30	22	30	42	77	117	192	352	658	818	954	1465	1554	2012	3499
40	38	50	70	131	191	303	521	964	1230	1435	2025	2340	3030	5050
50	54	66	99	195	264	432	750	1314	1783	2087	2824	3440	4398	7078
60	62	74	133	270	345	560	1059	1782	2531	2975	3900	4980	6247	9951
70	68	80	158	326	438	733	1440	2415	3539	4147	5520	7232	8743	13427
80	70	88	163	361	480	898	1919	3095	4568	5537	7432	10230	11880	16559
90	72	90	167	370	496	948	2069	3341	4817	5805	7808	11170	12609	17105

ASME CLASS 300 (INCHES)

Disc Position	Value Size 300#													
Degrees	2	2-1/2	3	4	5	6	8	10	12	14	16	18	20	24
10	2	3	4	6	8	12	15	42	65	115	190	340	525	740
20	4	7	18	31	35	88	157	274	434	538	689	893	1143	1923
30	13	22	42	75	101	182	335	547	805	985	1362	1652	2175	3359
40	24	38	71	114	166	285	506	843	1211	1455	1985	2437	3247	4889
50	36	46	99	157	229	406	716	1224	1731	1997	2697	3410	4370	6637
60	48	52	131	224	294	561	999	1701	2398	2558	3552	4399	5655	8492
70	52	54	158	286	376	758	1358	2305	3264	3288	4569	5575	6779	10544
80	55	56	163	367	427	954	1731	2937	3699	3736	5589	6634	7416	11748
90	58	65	164	383	435	972	1820	3039	3992	4001	5764	6729	7595	12122

The size of butterfly valve used for control purposes should be calculated on the basis of the operating characteristics. In order to achieve optimum control, the flow coefficient (Cv) of a valve needs to be considered. Cv is the volume of water in U.S. gallons per minute that passes through the valve at a pressure drop of 1 psi at 68°F. Flow for a given Cv is typically calculated from the following formula.

Where:

- Q = Valve flow rate in gallons per minute (US GPM)
- ΔP = Pounds per square inch (psi) pressure drop across valve
- 62.4 = Conversion factor for fluids computed in relation to water
- D = Density of fluids in pounds per cubic foot

$$Q = Cv \times \sqrt{\frac{\Delta P \times 62.4}{D}}$$

FIGURE HPA BUTTERFLY VALVES



HIGH-PERFORMANCE BUTTERFLY VALVE

TORQUE DATA (IN-LBS) ASME CLASS 150

SOFT SEAT

Valve Size		Differential Pressure (ΔP)				
		50 psi	100 psi	150 psi	230 psi	285 psi
Inch	DN	Preferred Flow Direction				
2	50	212	230	239	248	257
2-1/2	65	239	248	257	274	283
3	80	283	292	301	327	354
4	100	381	407	434	469	602
5	125	522	575	620	690	735
6	150	779	841	920	1027	1097
8	200	1310	1434	1549	1761	1894
10	250	1708	1938	2160	2505	2788
12	300	2080	2555	2974	3655	4116
14	350	3443	4266	5125	6505	7399
16	400	4390	5470	6585	8284	9523
18	450	5718	7151	8550	10833	12471
20	500	7629	9621	11471	14719	16790
24	600	11550	14586	17772	22640	26181
26	650	14135	17259	19560	23100	28057
28	700	15533	19029	22038	25048	29739
30	750	21198	25773	30349	37669	42705
32	800	27428	33297	40085	48290	55981
36	900	34208	42147	50086	62787	71523

FIRE SAFE SEAT

Valve Size		Differential Pressure (ΔP)				
		50 psi	100 psi	150 psi	230 psi	285 psi
Inch	DN	Preferred Flow Direction				
2	50	460	478	496	522	540
2-1/2	65	478	504	513	540	558
3	80	611	628	646	682	708
4	100	752	797	832	894	947
5	125	850	920	1000	1124	1213
6	150	1425	1549	1682	1885	2000
8	200	2337	2593	2788	3142	3425
10	250	3523	3921	4372	5063	5558
12	300	5248	6036	6797	7930	8824
14	350	6231	7143	8010	9559	10532
16	400	7187	8355	9683	11621	13055
18	450	9152	11409	13905	17524	20224
20	500	12949	16445	19817	25632	29349
24	600	20392	24109	28075	34394	38253
26	650	23181	28305	32079	37885	46013
28	700	25474	31208	36143	41078	48771
30	750	34764	42268	49773	61777	70036
32	800	44983	54606	65739	79195	91809
36	900	56101	69122	82142	102971	117298

NOTE:

- Flow from retainer side is the preferred flow direction. Flow from stem side is non-preferred flow direction. Arrow on valve body indicates the preferred flow direction.
- BTO-Break to Open; RTO-Run to Open; ETO-End to Open; BTC-Break to Close; RTC-Run to Close; ETC-End to Close.
- Above mentioned tabulated torque values are BTO and ETC for preferred flow direction.
- RTO, ETO, BTC and RTC = 40% of the above tabulated values for preferred direction.
- For non-preferred flow direction torque values of soft seat:
 - 2"-8" Multiply preferred values by 1.12
 - 10"-12" Multiply preferred values by 1.20
 - 14"-24" Multiply preferred values by 1.24
 - 26"-48" Multiply preferred values by 1.30
- For non-preferred flow direction torque values of fire safe seat and metal seat, multiply preferred values by 1.25.
- For actuator sizing, the minimum valve differential pressure shall be 50 psi. For differential pressure above 50 psi, the intermediated values to be interpolated. For gear operator sizing, the full rated torque to be considered.
- The published torque values are without factor of safety. The following factor of safety shall be considered for operator sizing:
 - Clean service (liquid, steam, clean gas and non-abrasive) = 1.3
 - High solids slurry = 1.5
 - Dry gas = 1.7

FIGURE HPA BUTTERFLY VALVES



HIGH-PERFORMANCE BUTTERFLY VALVE

TORQUE DATA (IN-LBS) ASME CLASS 300

SOFT SEAT

Valve Size		Differential Pressure (ΔP)				
		150 psi	285 psi	360 psi	580 psi	740 psi
Inch	DN	Preferred Flow Direction				
2	50	239	257	283	354	372
2-1/2	65	257	283	301	372	416
3	80	301	354	389	478	531
4	100	434	602	655	841	956
5	125	779	982	1089	1425	1646
6	150	1062	1363	1549	2071	2434
8	200	2018	2655	3018	4062	4824
10	250	2992	4080	4691	6470	7753
12	300	4186	5656	6426	8868	10524
14	350	6408	9364	11134	15993	19419
16	400	7780	11240	13205	19303	23410
18	450	10054	14621	17126	24658	29836
20	500	13285	19392	23056	33288	40616
24	600	18117	26366	30845	45148	54503

FIRE SAFE SEAT

Valve Size		Differential Pressure (ΔP)				
		150 psi	285 psi	360 psi	580 psi	740 psi
Inch	DN	Preferred Flow Direction				
2	50	496	540	558	593	620
2-1/2	65	513	558	584	620	655
3	80	646	708	726	770	814
4	100	832	947	1071	1275	1434
5	125	1097	1283	1390	1717	1921
6	150	1814	2186	2399	3009	3443
8	200	2983	3647	4009	5098	5833
10	250	4478	5399	5921	7417	8532
12	300	7302	9541	10639	14303	16816
14	350	8196	10683	12055	16170	19003
16	400	9939	13409	15312	21295	25402
18	450	15285	22587	26738	38811	47431
20	500	21286	32031	37589	55618	67089
24	600	34199	50494	59318	85923	104129

NOTE:

- Flow from retainer side is the preferred flow direction. Flow from stem side is non-preferred flow direction. Arrow on valve body indicates the preferred flow direction.
- BTO-Break to Open; RTO-Run to Open; ETO-End to Open; BTC-Break to Close; RTC-Run to Close; ETC-End to Close.
- Above mentioned tabulated torque values are BTO and ETC for preferred flow direction.
- RTO, ETO, BTC and RTC = 40% of the above tabulated values for preferred direction.
- For non-preferred flow direction torque values of soft seat, fire safe seat and metal seat, multiply preferred values by 1.25.
- For actuator sizing, the minimum valve differential pressure shall be 150 psi. For differential pressure above 150 psi, the intermediated values to be interpolated. For gear operator sizing, the full rated torque to be considered.
- The published torque values are without factor of safety. The following factor of safety shall be considered for operator sizing:
Clean service (liquid, steam, clean gas and non-abrasive) = 1.3
High solids slurry = 1.5
Dry gas = 1.7

FIGURE HPA BUTTERFLY VALVES



HIGH-PERFORMANCE BUTTERFLY VALVE

FIGURE NUMBER MATRIX

FNW HPA						
CLASS	CONNECTION	BODY MATERIAL	SEAT	OPERATOR	SIZE	
1 = 150# 3 = 300#	W = WAFER L = LUG	C = WCB - CARBON STEEL S = CF8M - STAINLESS STEEL	T = HYPERSEAT TFS = FIRESAFE	L = LEVER (STANDARD 2"-4")* G = GEAR (STANDARD 6"-24")* B = BARE STEM	2 = K 2-1/2 = L 3 = M 4 = P 5 = S 6 = U 8 = X 10 = 10 12 = 12	14 = 14 16 = 16 18 = 18 20 = 20 24 = 24 28 = 28 30 = 30 36 = 36
				*Lever available on 6" *Gear operator available on 2"-4"		

Example: Part Number for a Class 150#, Wafer Style Connection, Stainless Steel Body Material, Hyperseat, Gear Operator, 10" Size: **FNWHPA1WSTG10**

Other body and seat materials available

REPLACEMENT LEVER HANDLES

(ORDER SEPARATELY)

FNW HPA	Lever Handle	Size
	<i>Level Handle</i>	<i>Size Code</i>
	LH	2-1/2-4 = LMP
		5-6 = SU