

# STAINLESS STEEL - FEMALE COUPLER X HOSE SHANK, TYPE - C



A-A-59326D COMPATIBLE | MATERIALS: CF8M MOD

## STANDARD MATERIALS

Description	Material
Body	Stainless-Steel (#316)
Gasket	Buna-N (Standard Offer)
Arm	Stainless-Steel (#304)
Pin	Stainless-Steel
Pull-Ring	Stainless-Steel
Safety-Pin	Steel (Plated)

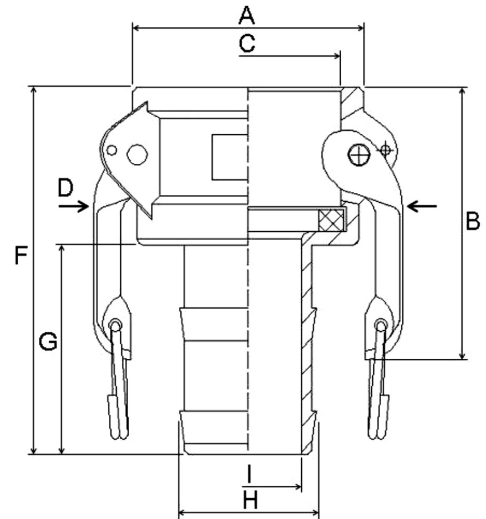

## DIMENSIONS (INCHES)

Product Code	SIZE	A	B	C	D	E	F	G	H	I
FNWCGCSSD	1/2"	1.32	1.92	1	1.8	2.56	3.43	2.19	0.57	0.3
FNWCGCSSF	3/4"	1.61	1.94	1.28	2.1	2.62	3.26	2	0.83	0.54
FNWCGCSSG	1"	1.85	2.19	1.47	2.4	2.91	3.79	2.25	1.06	0.78
FNWCGCSSH	1-1/4"	2.26	3.09	1.81	3.25	3.47	4.04	2.28	1.33	1.02
FNWCGCSSJ	1-1/2"	2.58	3.12	2.13	3.56	3.54	4.09	2.32	1.58	1.27
FNWCGCSSK	2"	2.91	3.14	2.51	3.93	3.52	5.08	3.11	2.07	1.75
FNWCGCSSM	3"	4.17	3.73	3.63	5.42	4.04	6.19	4	3.11	2.69
FNWCGCSSP	4"	5.45	3.74	4.73	6.52	4.75	6.44	4.25	4.11	3.68

\*E\* dimension for Arm & Ring "stretched", shown as Type-B specification sheet.