

**PCA-A36KA7 & PUZ-A36NKA7**  
**36,000 BTU/H CEILING SUSPENDED**  
**36,000 BTU/H HEAT PUMP UNIVERSAL OUTDOOR**



Job Name:

System Reference:

Date:



Indoor Unit.....PCA-A36KA7

Outdoor Unit.....PUZ-A36NKA7

**INDOOR UNIT FEATURES**

- Airflow settings for high and low ceiling applications
- Knock-out for outside-air intake
- Optional i-see Sensor™ for air distribution and energy saving
- Auto fan speed mode
- Filter status indicator
- Easy-to-clean, washable filter
- Suspends from ceiling for quick and easy installation
- Ideal for larger retail stores, classrooms, and restaurants
- Multiple control options available:
  - kumo cloud® smart device app for remote access
  - Third-party interface options
  - Wired or wireless controllers

**OUTDOOR UNIT FEATURES**

- Variable speed INVERTER-driven compressor
- Pre-charged with refrigerant volume for piping length up to 100 ft
- Low ambient cooling down to 0°F providing 100% capacity
- 24-hour continuous operation (cooling mode)
- High pressure protection
- Fast restart
- Superior energy and operational efficiency
- Seacoast protection\*
  - External Outer Panel: Phosphate coating + Acrylic-Enamel coating
  - Fan Motor Support: Epoxy resin coating (at edge face)
  - Separator Assembly Valve Bed: Epoxy resin coating (at edge face)
  - Blue Fin treatment is an anti-corrosion treatment that is applied to the Heat exchanger coil to protect it against airborne contaminants.
  - Heat exchanger coil and base panel rated for 2,000 hours in accordance with ASTM B117 testing

\*Seacoast protection standard from 2022 production

# SPECIFICATIONS: PCA-A36KA7 & PUZ-A36NKA7

Cooling at 95°F <sup>1</sup>	Maximum Capacity	BTU/H	36,000
	Rated Capacity	BTU/H	36,000
	Minimum Capacity	BTU/H	16,000
	Maximum Power Input	W	3,270
	Rated Power Input	W	3,270
	Moisture Removal	Pints/h	8.7
	Sensible Heat Factor		0.73
Heating at 47°F <sup>2</sup>	Maximum Capacity	BTU/H	40,000
	Rated Capacity	BTU/H	38,000
	Minimum Capacity	BTU/H	17,900
	Maximum Power Input	W	3,420
	Rated Power Input	W	2,410
	Power Factor [208V / 230V]	%	92.7 / 92.7
Heating at 17°F <sup>3</sup>	Maximum Capacity	BTU/H	24,400
	Rated Capacity	BTU/H	21,000
	Maximum Power Input	W	2,490
	Rated Power Input	W	2,430
Heating at 5°F <sup>4</sup>	Maximum Capacity	BTU/H	20,000
	Maximum Power Input	W	3,100
Efficiency	SEER   SEER2		19.1   19.5
	EER <sup>1</sup>   EER2 <sup>1</sup>		11.0   11.0
	HSPF [IV]   HSPF2 [IV]		10.2   8.9
	COP at 47°F <sup>2</sup>		4.62
	COP at 17°F at Maximum Capacity <sup>3</sup>		2.88
	COP at 5°F at Maximum Capacity <sup>4</sup>		1.89
Electrical	ENERGY STAR® Certified		No
	Voltage, Phase, Frequency		208/230, 1, 60
	Guaranteed Voltage Range	V AC	198 - 253
	Voltage: Indoor - Outdoor, S1-S2	V AC	208/230
	Voltage: Indoor - Outdoor, S2-S3	V DC	24
	Short-circuit Current Rating [SCCR]	kA	5
	Recommended Fuse/Breaker Size (Outdoor)	A	30
	Recommended Wire Size [Indoor - Outdoor]	AWG	14
	Power Supply		Indoor unit is powered by the outdoor unit
	Indoor Unit	MCA	A
Fan Motor Full Load Amperage		A	0.97
Fan Motor Type			DC Motor
Airflow Rate at Cooling, Dry		CFM	775-850-920-990
Airflow Rate at Cooling, Wet		CFM	705-775-850-920
Airflow Rate at Heating, Dry		CFM	775-850-920-990
Sound Pressure Level [Cooling]		dB[A]	37-39-41-43
Sound Pressure Level [Heating]		dB[A]	37-39-41-43
Drain Pipe Size		In. [mm]	1-1/32 [26]
Coating on Heat Exchanger			—
External Finish Color			White Munsell 6.4Y 8.9/0.4
Unit Dimensions		W x D x H: In. [mm]	63 x 26-3/4 x 9-1/16 [1,600 x 680 x 230]
Package Dimensions		W x D x H: In. [mm]	65-3/4 x 29-15/16 x 13-3/4 [1,670 x 760 x 350]
Unit Weight		Lbs. [kg]	79 [36]
Package Weight		Lbs. [kg]	93 [42]
Indoor Unit Operating Temperature Range	Cooling Intake Air Temp [Maximum / Minimum]*	°F	90 DB, 72 WB / 68 DB, 61 WB
	Heating Intake Air Temp [Maximum / Minimum]	°F	77 DB / 59 DB

**NOTES:**

AHRI Rated Conditions  
 (Rated data is determined at a fixed compressor speed)

<sup>1</sup>Cooling (Indoor // Outdoor) °F 80 DB, 67 WB // 95 DB, 75 WB  
<sup>2</sup>Heating at 47°F (Indoor // Outdoor) °F 70 DB, 60 WB // 47 DB, 43 WB  
<sup>3</sup>Heating at 17°F (Indoor // Outdoor) °F 70 DB, 60 WB // 17 DB, 15 WB

Conditions <sup>4</sup>Heating at 5°F (Indoor // Outdoor) °F 70 DB, 60 WB // 5 DB, 4 WB

**\*Indoor/Outdoor Unit Operating Temperature Range (Cooling Air Temp [Maximum / Minimum]):**

- Applications should be restricted to comfort cooling only; equipment cooling applications are not recommended for low ambient temperature conditions.
- » Wind baffles required to operate below 23°F DB in cooling mode.
- » Heat pump system with wind baffle: 0°F - 115°F.
- » Refer to wind baffle documentation for further information.

**\*\*Outdoor Unit Operating Temperature Range (Cooling Thermal Lock-out / Re-start Temperatures; Heating Thermal Lock-out / Re-start Temperatures):**

- System cuts out in heating mode to avoid thermistor error and automatically restarts at these temperatures.

**\*\*\*Blue Fin Coating Standard from 2022 production:**

- PU(Y/Z)-A(12/18)NKA7 - Beginning with serial number 12U\*\*\*\*\*
- PU(Y/Z)-A(24/30/36/42)NKA7 - Beginning with serial number 12U\*\*\*\*\*

# SPECIFICATIONS: PCA-A36KA7 & PUZ-A36NKA7

Outdoor Unit	MCA	A	25.0
	MOCP	A	31
	Fan Motor Full Load Amperage	A	0.5 + 0.5
	Fan Motor Output	W	74
	Airflow Rate [Cooling / Heating]	CFM	3880 / 3880
	Refrigerant Control		LEV
	Defrost Method		Reverse Cycle
	Coating on Heat Exchanger		Blue Fin Coating***
	Sound Pressure Level, Cooling <sup>1</sup>	dB(A)	52
	Sound Pressure Level, Heating <sup>2</sup>	dB(A)	53
	Compressor Type		INVERTER-driven twin rotary
	Compressor Model		MNB33FBRMC-L
	Compressor Rated Load Amps	A	8
	Compressor Locked Rotor Amps	A	13.0
	Compressor Oil [Type // Charge]	oz.	FV50S // 45
	External Finish Color		Ivory Munsell 3Y 7.8/1.1
	Base Pan Heater		N/A
	Unit Dimensions	W x D x H: In. [mm]	41-5/16 x 13 (+1-3/16) x 52-11/16 [1050 x 330 (+30) x 1338]
	Package Dimensions	W x D x H: In. [mm]	42-15/16 x 17-11/16 x 56-4/16 [1091 x 450 x 1429]
	Unit Weight	Lbs. [kg]	214 [97]
	Package Weight	Lbs. [kg]	245 [111]
Outdoor Unit Operating Temperature Range	Cooling Air Temp [Maximum / Minimum]*	°F	115 DB / 0 DB
	Heating Air Temp [Maximum / Minimum]	°F	70 DB, 59 WB / -4 DB, -4 WB
	Heating Thermal Lock-out / Re-start Temperatures**	°F	-8 / -4
Refrigerant	Type		R410A
	Pre-Charged Refrigerant Amount	Lbs, oz	10.0, 6.0
	Maximum Pre-Charged Piping Length	Ft. [m]	100.0 [30.0]
	Additional Refrigerant Charge Per Additional Piping Length	oz./Ft. [g/m]	0.7 [50]
Piping	Gas Pipe Size O.D. [Flared]	In.[mm]	5/8 [15.88]
	Liquid Pipe Size O.D. [Flared]	In.[mm]	3/8 [9.52]
	Maximum Piping Length	Ft. [m]	165 [50]
	Maximum Height Difference	Ft. [m]	100 [30]
	Maximum Number of Bends		15

### NOTES:

AHRI Rated Conditions  
 (Rated data is determined at a fixed compressor speed)

<sup>1</sup>Cooling (Indoor // Outdoor) °F 80 DB, 67 WB // 95 DB, 75 WB  
<sup>2</sup>Heating at 47°F (Indoor // Outdoor) °F 70 DB, 60 WB // 47 DB, 43 WB  
<sup>3</sup>Heating at 17°F (Indoor // Outdoor) °F 70 DB, 60 WB // 17 DB, 15 WB

Conditions  
<sup>4</sup>Heating at 5°F (Indoor // Outdoor) °F 70 DB, 60 WB // 5 DB, 4 WB

### \*Indoor/Outdoor Unit Operating Temperature Range (Cooling Air Temp [Maximum / Minimum]):

- Applications should be restricted to comfort cooling only; equipment cooling applications are not recommended for low ambient temperature conditions.
- » Wind baffles required to operate below 23°F DB in cooling mode.
- » Heat pump system with wind baffle: 0°F - 115°F.
- » Refer to wind baffle documentation for further information.

### \*\*Outdoor Unit Operating Temperature Range (Cooling Thermal Lock-out / Re-start Temperatures; Heating Thermal Lock-out / Re-start Temperatures):

- System cuts out in heating mode to avoid thermistor error and automatically restarts at these temperatures.

### \*\*\*Blue Fin Coating Standard from 2022 production:

- PU(Y/Z)-A(12/18)NKA7 - Beginning with serial number 12U\*\*\*\*\*
- PU(Y/Z)-A(24/30/36/42)NKA7 - Beginning with serial number 12U\*\*\*\*\*

## INDOOR UNIT ACCESSORIES: PCA-A36KA7

Control Interface	BACnet® and Modbus® Interface	PAC-UKPRC001-CN-1
	CN24 Relay Kit	CN24RELAY-KIT-CM3
	IT Extender	PAC-WHS01IE-E
	kumo station® for kumo cloud®	PAC-WHS01HC-E
	Remote Operation Adapter†	PAC-SF40RM-E
	Thermostat Interface	PAC-US444CN-1
	Thermostat Interface	PAC-US445CN-1
	USNAP Adapter	PAC-WHS01UP-E
Remote Sensor	Wireless Interface for kumo cloud®	PAC-USWHS002-WF-2
	Flush Mount Remote Temperature Sensor	PAC-USSEN002-FM-1
	Flush Mount Temperature Sensor	PAC-USSEN001-FM-1
	Remote Temperature Sensor	PAC-SE41TS-E
Wired Remote Controller	Wireless temperature and humidity sensor for kumo cloud®	PAC-USWHS003-TH-1
	Deluxe Wired MA Remote Controller†	PAR-40MAAU
	Simple Ductless Wired Remote Controller	PAC-SDW01RC-1
	Simple MA Remote Controller†	PAC-YT53CRAU-J
Wireless Remote Controller	Touch MA Controller†	PAR-CT01MAU-SB
	kumo touch™ RedLINK™ Wireless Controller	MHK2
	Lockdown bracket for remote controller	RCMKP1CB
	Wireless MA Receiver	PAR-FA32MA-W
	Wireless MA Remote Controller	PAR-FL32MA-E
	Wireless Receiver Kit	PAR-SL93B-E
Condensate	Wireless Receiver Kit with i-See sensor™	PAR-SA92MW-E
	Blue Diamond (Advanced) Mini Condensate Pump w/ Reservoir & Sensor (208/230V) [recommended]	X87-721
	Blue Diamond (MegaBlue Advanced) Condensate Pump w/ Reservoir & Sensor	X87-835
Disconnect Switch	Refco Condensate Pump (100-240 VAC) up to 120,000 BTU/H	COMBI
Filter	(30A/600V/UL) [fits 2" X 4" utility box] - Black	TAZ-MS303
Lineset	65% Medium Efficiency Filter (MERV 8)	PAC-SH90KF-E
	10' x 3/8" x 10' x 5/8" Lineset (Twin-Tube Insulation)	MPLS385812T-10
	100' x 3/8" x 100' x 5/8" Lineset (Twin-Tube Insulation)	MPLS385812T-100
	15' x 3/8" x 15' x 5/8" Lineset (Twin-Tube Insulation)	MPLS385812T-15
	30' x 3/8" x 30' x 5/8" Lineset (Twin-Tube Insulation)	MPLS385812T-30
	50' x 3/8" x 50' x 5/8" Lineset (Twin-Tube Insulation)	MPLS385812T-50
	65' x 3/8" x 65' x 5/8" Lineset (Twin-Tube Insulation)	MPLS385812T-65

**NOTES:**

†PAC-SF40RM-E (Unable to use with wireless remote controller)

## OUTDOOR UNIT ACCESSORIES: PUZ-A36NKA7

Air Outlet Guide	Air Outlet Guide (1 Piece)	PAC-SH96SG-E (two pieces are required)
Control/Service Tool	Control/Service Tool	PAC-SK52ST
	M- & P-Series Maintenance Tool Cable Set	M21EC0397
	USB/UART Conversion Cable (Required for all laptop connection)	M21EC1397
M-NET Converter	M-NET Converter	PAC-SJ85MA-E
	M-NET Converter	PAC-SJ95MA-E
Mini-Split Wire	14 Gauge, 4 wire MiniSplit Cable—250 ft. roll	S144-250
	14 Gauge, 4 wire MiniSplit Cable—50 ft. roll	S144-50
	16 Gauge, 4 wire MiniSplit Cable—250 ft. roll	S164-250
	16 Gauge, 4 wire MiniSplit Cable—50 ft. roll	S164-50
Mounting Pad	Condensing Unit Mounting Pad: 24" x 42" x 3"	ULTRILITE2
Stand	18" Dual Fan Stand	QSMS1802M
	24" Dual Fan Stand	QSMS2402M
	Condenser Wall Bracket	QSWB2000M-1
	Condenser Wall Bracket - Stainless Steel Finish	QSWBSS
	Outdoor Unit Stand — 12" High	QSMS1202M
Wind Baffle	Front Wind Baffle	WB-PA3 (two pieces are required)
	Rear Wind Baffle	WB-RE6
	Side Advanced Wind Baffle	WB-SD6

# INDOOR UNIT DIMENSIONS: PCA-A36KA7

Unit: in (mm)

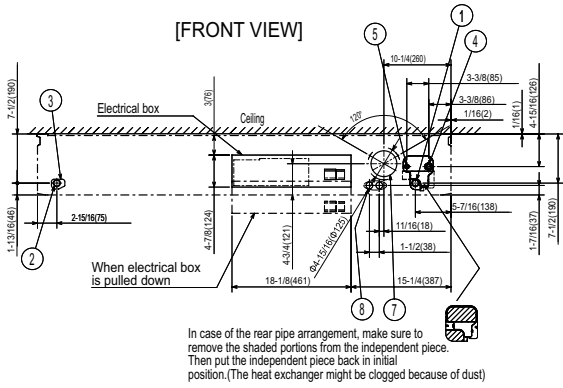

NOTES.  
 1. Use M10 or W3/8 screw for anchor bolt.  
 2. Please be sure when installing the drain pump (option parts), refrigerant pipe will be only upward.

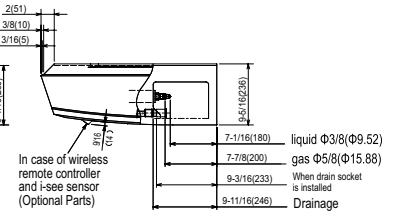
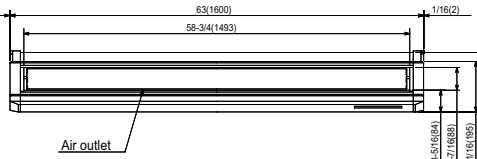
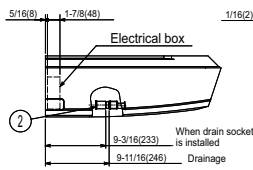
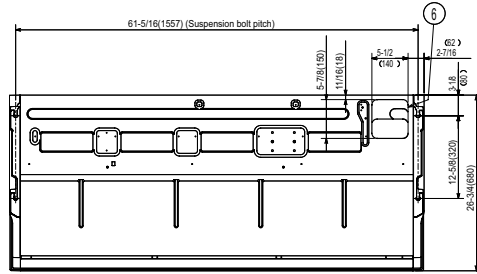

- ① Drainage pipe connection(1(26mm)I.D.)
- ② Drainage pipe connection(for the left arrangement)
- ③ Knockout hole for left drain-piping arrangement
- ④ Refrigerant-pipe connection (gas pipe side/flared connection)
- ⑤ Refrigerant-pipe connection (liquid pipe side/flared connection)
- ⑥ Knockout hole for upper drain pipe arrangement
- ⑦ Knockout hole for fresh air intake  $\Phi 3-15/16(\Phi 100)$
- ⑧ Knockout hole for wiring arrangement  $\Phi 7/8(\Phi 22)$  Accessory..Drain socket (1(26mm)I.D.)

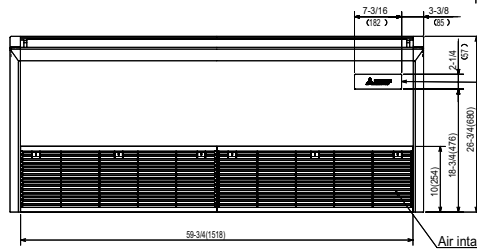

In case of wireless remote controller and i-see sensor(Optional Parts)

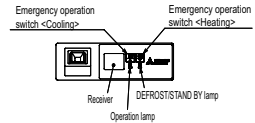

# OUTDOOR UNIT DIMENSIONS: PUZ-A36NKA7

Unit: mm<in>

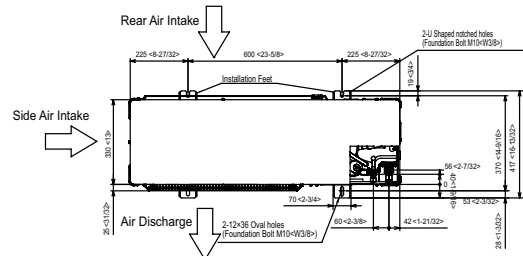
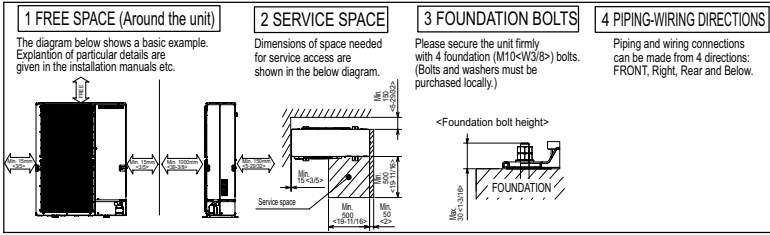

## Example of Notes

- ① - Refrigerant GAS pipe connection (FLARE)  $\phi$ 15.88(5/8F)
- ② - Refrigerant LIQUID pipe connection (FLARE)  $\phi$ 9.52(3/8F)
- \*1 ... Indication of STOP VALVE connection location.

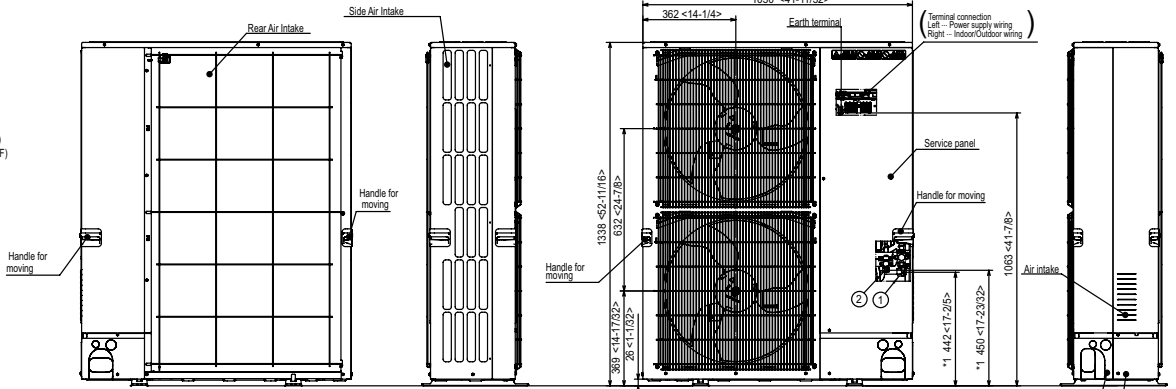

## Piping Knockout Hole Details

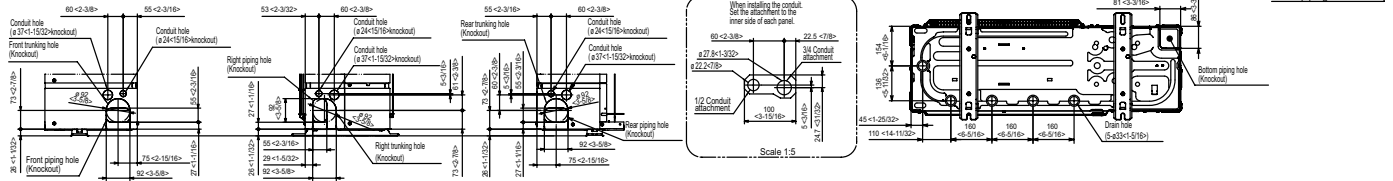

1340 Satellite Boulevard Suwanee, GA 30024  
 Toll Free: 800-433-4822 www.mehvac.com

