

SUBMITTAL DATA: PLA-A24EA7 & PUY-A24NHA7
24,000 BTU/H CEILING CASSETTE AIR-CONDITIONING SYSTEM

Job Name:	Engineer:
Purchaser:	Application: Std. Cooling Ultra Low Ambient Cooling
Submitted To:	For: <input type="checkbox"/> Reference <input type="checkbox"/> Approval <input type="checkbox"/> Construction
Submitted By:	Location:
System Designation:	Schedule No.:



Indoor Unit: PLA-A24EA7



Outdoor Unit: PUY-A24NHA7 (-BS)

UNIT OPTION:

Standard Model.....PUY-A24NHA7
Seacoast (BS) Model.....PUY-A24NHA7-BS

ACCESSORIES:

Indoor Unit

Multifunction Casement / High Efficiency Filter (PAC-SJ41TM-E / PAC-SH59KF-E)
Grille with 3D i-see Sensor™ (PLP-41EAEU) - (Required ordered separately)

Optional Controls

- Wireless Controller (MHK1)
- Advanced Wired Controller (PAR-40MAA)
- Simple Wired Controller (PAC-YT53CRA)
- Thermostat Interface (PAC-US444CN)
- Wireless Remote Controller (PAR-FL32MA)(Requires Signal Receiver (PAR-SR4LU-E))
- M-NET Adapter (PAC-SJ95MA-E)

Outdoor Unit

- Front Wind Guard (PFR-24-30)
- Rear Wind Guard (PRE-24-30)
- Side Wind Guard (PSD-24-30)

Note: Mitsubishi Electric (MESCA) supports the use of only MESCA supplied and approved Snow Guard / Wind Deflectors / Windscreens and accessories for proper functioning of the unit(s). Use of non-MESCA supported Snow Guard / Wind Deflectors / Windscreens and accessories will affect warranty coverage.

SPECIFICATIONS:

Rated Conditions (Capacity / Input)*		
Cooling	Btu/h / W	24,000 / 1,670

* Rating Conditions per AHRI Standard:
Cooling | Indoor: 80°F (27°C) DB / 67°F (19°C) WB
Cooling | Outdoor: 95°F (35°C) DB / 75°F (24°C) WB

Capacity Range		
Cooling	Btu/h	10,000 - 24,000

Operating Range		
Cooling		-40F** (-40.0°C) to 115°F (46°C) DB

** Windscreens required for cooling operation below 23°F (-5°C)

AHRI Efficiency Rating	
EER	14.3
SEER	24.2

Electrical Power Requirements	
	208 / 230V, 1-Phase, 60 Hz

Minimum Circuit Ampacity (MCA) *		Breaker Size	MOCPP (Outdoor)
Indoor 1 AMP	Outdoor 19 AMP	25 AMP	26 AMP

***All electrical work shall comply with National (CEC) and local codes and regulations.**

Indoor Unit		
Fan Motor (ECM)	F.L.A.	0.60
Fan Motor Output	W	120
SHF / Moisture Removal		0.86 / 3.0 pt./h
Drain Lift Mechanism (Included)	H: In.	33-7/16
Field Drainpipe Size O.D.	In.(mm)	1-1/4 (32)

Outdoor Unit		
Compressor		DC INVERTER-driven Twin Rotary
Fan Motor (ECM)	F.L.A.	0.4
Fan Motor Power	W	86

Airflow Rate (Low-M1-M2-Hi)			
Indoor (Cooling)	DRY	CFM	530-640-710-810
	WET		490-600-670-770
Outdoor	DRY		1,940

Sound Pressure Level		
Indoor (Low-M1-M2-Hi)	dB(A)	28-30-33-36
Outdoor Cooling		47

External Dimensions			
Indoor (H x W x D)	In.(mm)	11-3/4 [1-9/16] x 33-3/32 [37-13/32] x 33-3/32 [37-13/32]	
Grille ([H x W x D])		(298 [40] x 840 [950] x 840 [950])	
Outdoor (H x W x D)		37-1/8 x 37-13/32 x 13 + 1-3/16 (943 x 950 x 330 + 30)	

Net Weight		
Indoor (Unit / Grille)	Lbs.(kg)	56 / 11 (25 / 5)
Outdoor		151 (68)

External Finish	
Indoor	Munsell 1.0Y 9.2/0.2
Outdoor	Ivory Munsell No. 3Y 7.8 / 1.1

Refrigerant	
	R410A ; 7lbs., 11oz. (3.5kg)

Refrigerant Piping (Flared)		
Liquid (High Pressure)	In.(mm)	3/8 (9.52)
Gas (Low Pressure)		5/8 (15.88)
Maximum Total Refrigerant Pipe Length	Fl. (m)	225 (69)
Maximum Vertical Separation	Fl. (m)	100 (30)

Specifications are subject to change without notice.

Should this document be altered or changed without MESCA's permission, it becomes null and void. MESCA assumes no responsibility for any consequences in such cases.

DIMENSIONS: PLA-A24EA7

Unit: in. (mm)

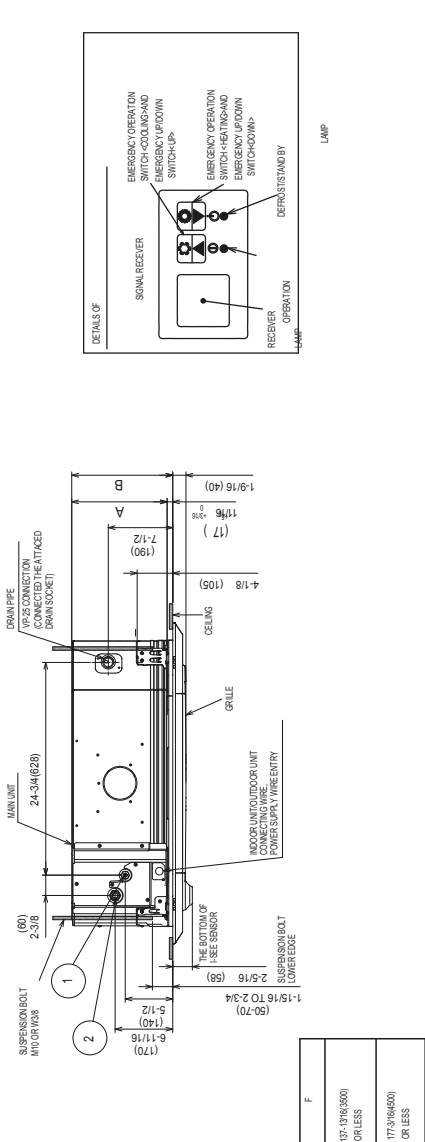
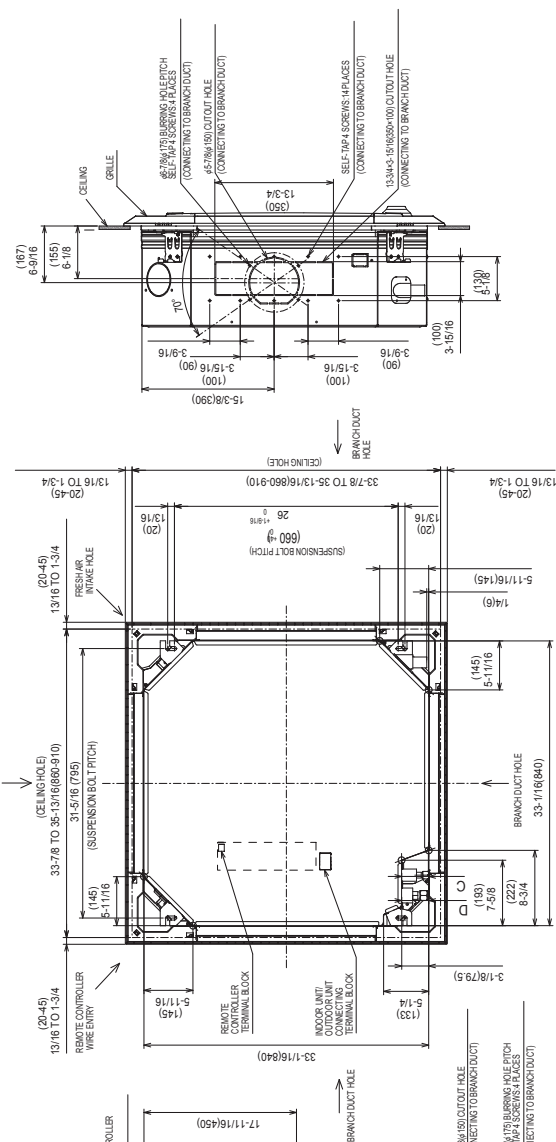
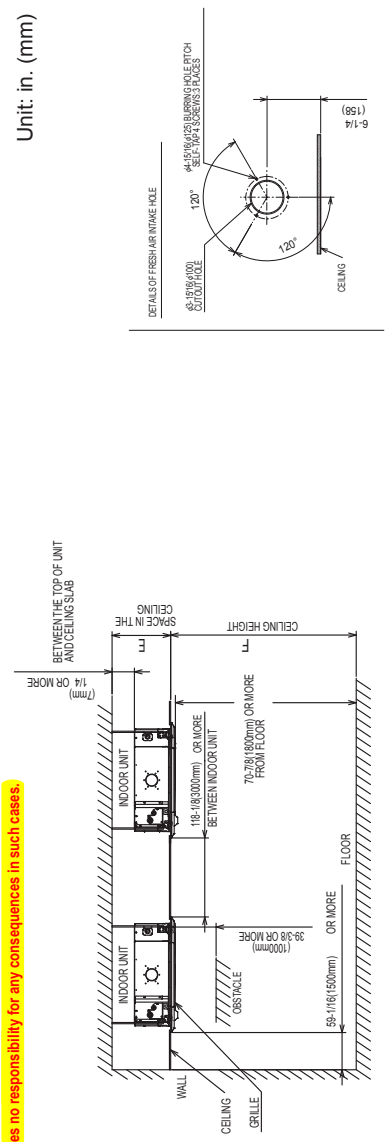

1. CHOOSE THE GRILLE AMONG THE DEDICATED GRILLES.
 2. REINFORCE THE SUSPENSION BOLT FOR EARTHQUAKE RESISTANCE AS NEEDED.
 3. FOR THE SUSPENSION BOLT, USE M10 OR W3/8. (PROCURED AT THE LOCAL SITE.)
 4. FOR DRAIN PIPE, USE VP-25(O.D. 1-1/4" (32) PVC TUBE). DRAIN PUMP INCLUSION. RAISE IS MAX 33-7/16" (850mm) FROM THE CEILING.
 5. ELECTRICAL BOX MAY BE REMOVED FOR THE SERVICE PURPOSE.
- MAKE SURE TO SLACK THE ELECTRICAL WIRE LITTLE BIT FOR CONTROL/POWER WIRES CONNECTION.
6. THE HEIGHT OF THE INDOOR UNIT IS ABLE TO BE ADJUSTED WITH THE GRILLE ATTACHED.
 7. REQUIRES "E" OR MORE SPACE BETWEEN TRANSOM AND CEILING FOR THE INSTALLATION.
 8. WHEN INSTALLING THE BRANCH DUCTS, BE SURE TO INSULATE ADEQUATELY.
 9. OTHERWISE CONDENSATION AND DRIPPING MAY OCCUR (IT BECOMES THE CAUSE OF DROPLET OR DRIPLETT DRIPPING).
 10. FOR NECESSARY INSTALLATION SERVICE SPACE, PLEASE REFER TO THE RIGHT AT FIGURE.
 11. FOR THE INSTALLATION OF THE OPTIONAL HIGH EFFICIENCY FILTER OR MULTI-FUNCTIONAL CASEMENT, REFER TO SPECIAL DRAWING.

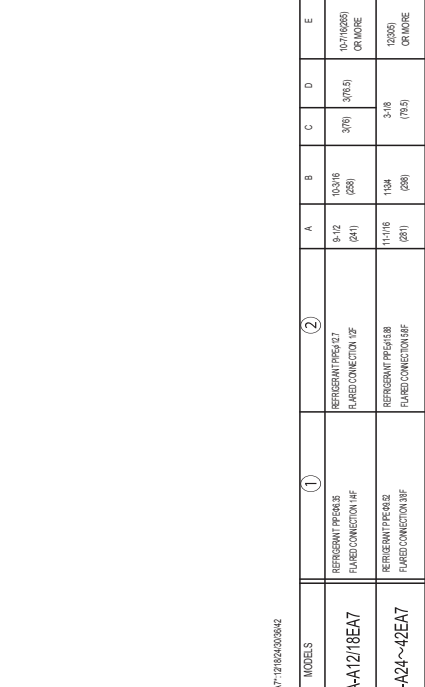
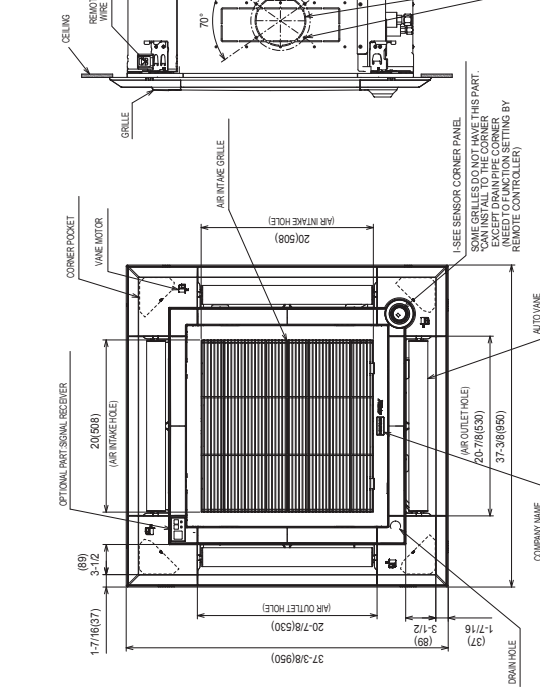

Specifications are subject to change without notice.

MODELS	②					
	A	B	C	D	E	F
PLA-A12/18EA7	9-1/2 (241)	10-3/16 (268)	3/8 (95)	10-7/16 (268)	OR MORE	10-7/16 (268) OR LESS
PLA-A24~42EA7	11-1/8 (288)	11-3/8 (291)	3/8 (95)	11-3/8 (291)	OR MORE	11-3/8 (291) OR LESS

DIMENSIONS: PUY-A24NHA7

Unit: mm (in.)

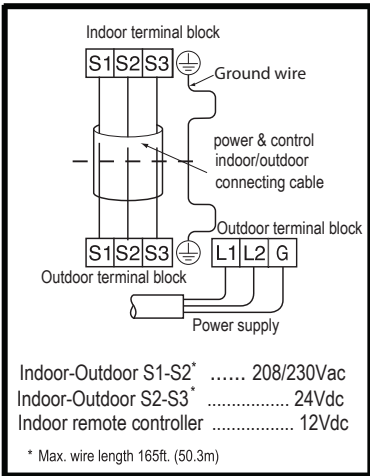
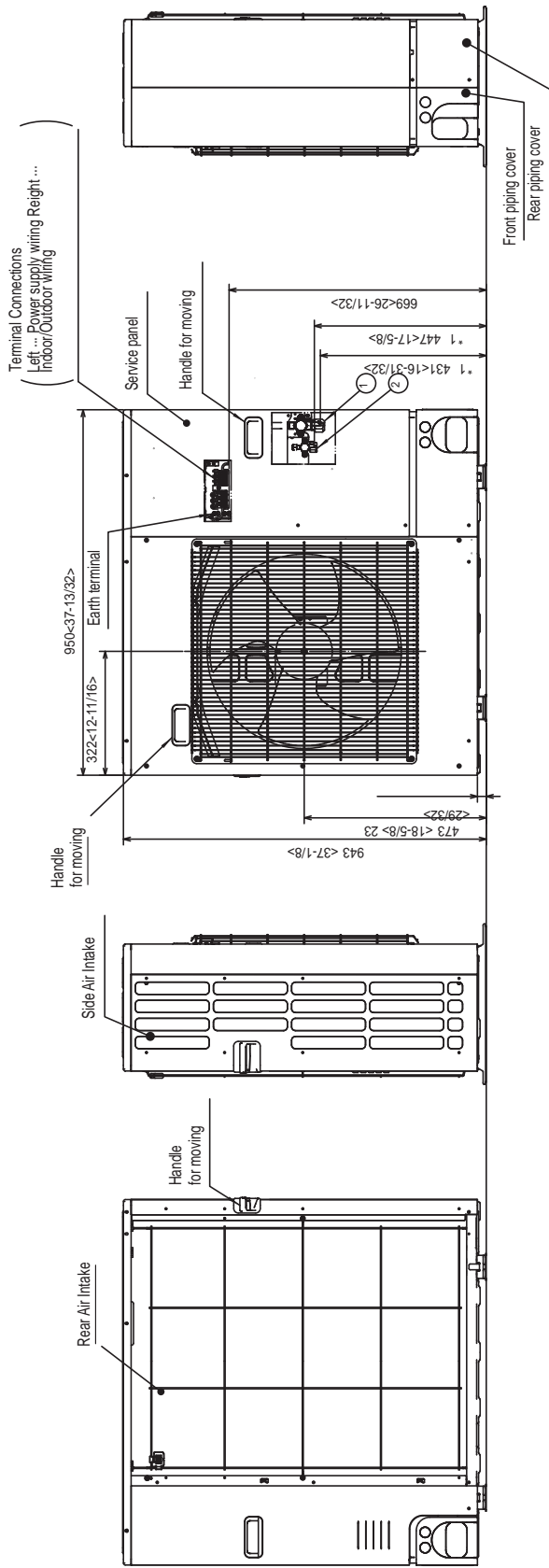
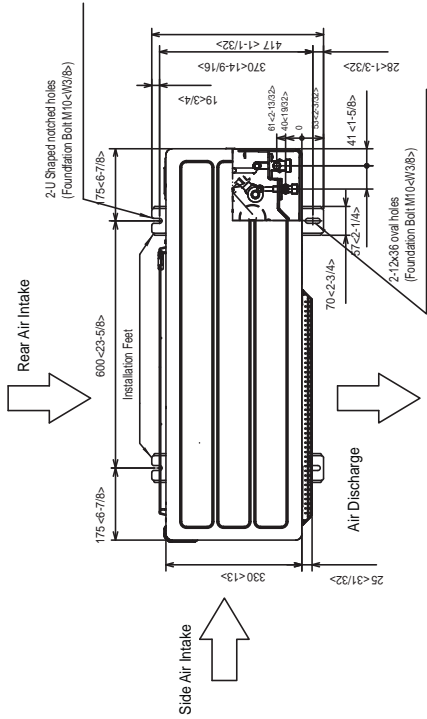

Should this document be altered or changed without MESCA's permission, it becomes null and void. MESCA assumes no responsibility for any consequences in such cases.

