

300 PSI WWP UL/FM Butterfly Valves

Designed for normally closed position monitoring



NSF/ANSI 61
NSF/ANSI 372

Fire Protection Valve • Grooved Mechanical Style • Nylon Coated Ductile Iron Body • Extended Neck • Elastomer Encapsulated Disc • Factory Installed Internal Monitoring Switches • Compatible with IPS Pipe†

300 PSI/20.7 Bar Non-Shock Cold Water 2½" - 10"

Warning: These valves are not to be used between the water source and sprinkler head.

UL/ULC LISTED** • 2½" - 10" LISTED FOR INDOOR AND OUTDOOR SERVICE • THIRD PARTY CERTIFIED TO NSF/ANSI 61 AND 372



GD-4865-C-8N

2½", 3", 4", 6", 8", 10"

MATERIAL LIST

PART	SPECIFICATION
1 Indicator Flag	Painted Steel
2 Stem Adapter	Steel
3 Gear Operator	Cast Iron and Steel
4 Retaining Ring	Carbon Steel
5 Cartridge Seal	Brass ASTM C36000
6 Stem Seals	EPDM
7 Upper Stem	Stainless Steel ASTM A582 Type 416
8 Upper Bushing	Plated Steel with PTFE Lining
9 Body	Ductile Iron ASTM A395 with Polyamide Coating
10 Disc	Ductile Iron ASTM A536 with EPDM Encapsulation
11 Lower Bushing	Steel with PTFE Lining
12 Lower Stem	Stainless Steel ASTM A582 Type 416
13 Handwheel	Cast Iron

Note: Comes with two factory mounted internal supervisory switches. Uses NIBCO model T1447532 PP switch. See of I & M manual for installation and wiring instructions.

Ground post or wall post not available.
Normally closed monitored.

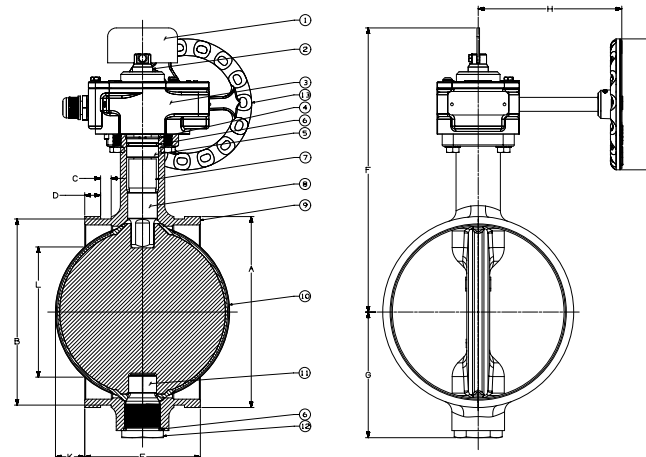

DIMENSIONS—WEIGHTS

SIZE	Dimensions																Weight								
	A	B	C	D	E	F	G	H	J	K	L	Lbs.	Kg.												
2½"	65	2.88	73	2.72	69	0.31	8	0.63	16	3.81	97	8.95	227	2.20	56	4.92	125	4.25	108	—	—	—	—	9.5	4.3
3 OD	76.1	3.00	76.1	2.85	72	0.31	8	0.63	16	3.81	97	9.16	233	2.47	63	4.92	125	4.25	108	—	—	—	—	11.3	5.2
3	80	3.50	80.0	3.34	85	0.31	8	0.63	16	3.81	97	9.16	233	2.47	63	4.92	125	4.25	108	—	—	—	—	11.6	5.3
4	100	4.50	114.3	4.33	110	0.38	10	0.63	16	4.56	116	10.00	254	3.00	76	4.92	125	4.25	108	—	—	—	—	15.0	6.8
6 OD	165.1	6.50	165.1	6.33	161	0.38	10	0.63	16	5.81	148	11.92	303	4.33	110	6.48	165	6	152	—	—	—	—	31.5	14.3
6	150	6.63	168.3	6.45	164	0.38	10	0.63	16	5.81	148	11.92	303	4.33	110	6.48	165	6	152	—	—	—	—	31.3	14.2
8	200	8.63	219	8.44	214	0.44	11	0.75	19	5.25	133	12.85	326	5.67	114	6.48	165	6	152	1.32	34	5.87	149	43.0	19.5
10	250	10.77	250	10.55	268	0.50	13	0.75	19	6.25	159	15	381	6.77	172	8.74	222	6	152	1.74	44	7.44	189	77.0	35

** Compliance with the Standard for Butterfly Valves for Fire Protection Service, UL 1091 and Indicating Valves, FM Class Number 1112.

† See Grooved Pipe Specification section

Visit our website for the most current information.