



# Model 95

## Premium Sump Pump

### Features:

- 5-year warranty
- Advanced switch technology allowing longer switch life (available in automatic only)
- 1/2 HP Premium 115 V sump pump
- Performance up to 26' (7.9 m) TDH
- Flows up to 80 GPM (303 LPM)
- Green LED plug showing power to the pump
- Viton switch arm boot and heavy-duty rubber power cord for longevity and durability
- Corrosion-resistant, powder coated epoxy paint

**100% factory tested**



Trusted. Tested. Tough.®

zoellerpumps.com 800-928-7867  
3649 Cane Run Road, Louisville, KY 40211 USA



FM2991  
0720  
Supersedes  
0420

## PRODUCT SPECIFICATIONS

<b>MOTOR</b>	Horse Power	1/2
	Voltage	115
	Phase	1 Ph
	Hertz	60 Hz
	RPM	3450
	Type	Permanent split capacitor
	Insulation	Class B
	Amps	10.5
<b>PUMP</b>	Operation	Automatic
	Auto On/Off Points	9-1/2" (24 cm) / 2-1/2" (6.4 cm)
	Discharge Size	1-1/2" NPT
	Solids Handling	1/2" (12 mm) spherical solids
	Cord Length	15' (4.6 m)
	Cord Type	UL listed, 3-wire, grounded plug
	Max. Head	26' (7.9 m)
	Max. Flow Rate	80 GPM (303 LPM)
	Max. Operating Temp.	130° F (54° C)
	Cooling	Oil filled
	Motor Protection	Auto reset thermal overload
<b>MATERIALS</b>	Cap	Cast iron
	Motor Housing	Cast iron
	Pump Housing	Cast iron
	Base	Cast iron
	Upper Bearing	Sleeve bearing
	Lower Bearing	Ball bearing
	Mechanical Seals	Carbon and ceramic
	Impeller Type	Non-clogging vortex
	Impeller	Engineered thermoplastic
	Hardware	Stainless steel
	Motor Shaft	AISI 1215 cold rolled steel
	Gasket	Neoprene

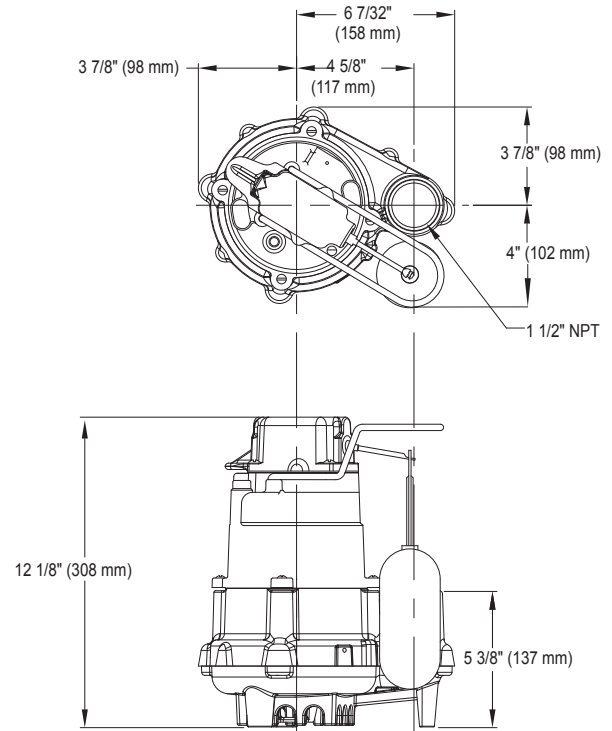

SK3129

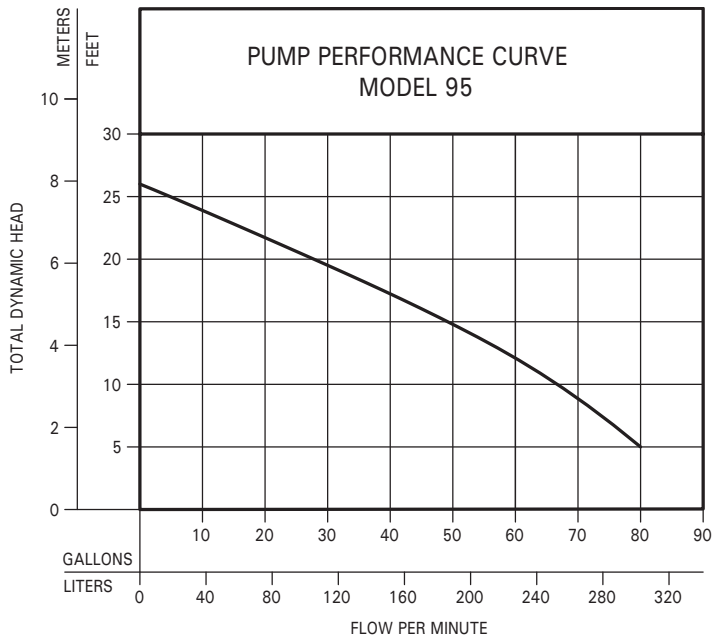

154422

  
 Tested to Standard UL778 and  
 Certified to CSA  
 Standard C22.2 No. 108





© Copyright 2020 Zoeller® Co. All rights reserved.

502-778-2731 | 800-928-7867 | 3649 Cane Run Road | Louisville, KY 40211-1961 | zoellerpumps.com