

## For Residential and Commercial Applications

Job Name \_\_\_\_\_

Contractor \_\_\_\_\_

Job Location \_\_\_\_\_

Approval \_\_\_\_\_

Engineer \_\_\_\_\_

Contractor's P.O. No. \_\_\_\_\_

Approval \_\_\_\_\_

Representative \_\_\_\_\_

# LEAD FREE\*

## Series LFRC105 Water Pressure Reducing Valves\*\*

Sizes: 3/4" – 1"

Series LFRC105 Water Pressure Reducing Valves are designed to reduce incoming water pressure to a sensible level to protect plumbing system components and reduce water consumption. The LFRC105 features Lead Free\* construction to comply with Lead Free\* installation requirements. This series is suitable for water supply pressures up to 300psi (20.1 bar) and may be adjusted from 25 – 75psi (172 – 517 kPa). The standard setting is 50psi (345 kPa). All parts are quickly and easily serviceable without removing the valve from the line. The standard bypass feature permits the flow of water back through the valve into the main when pressures, due to thermal expansion on the outlet side of the valve, exceed the pressure in the main supply.

### Features

- Integral stainless steel strainer
- Engineered composite seat & cage
- Lead Free\* cast copper silicon alloy body construction
- Serviceable in line
- Bypass feature controls thermal expansion pressure\*\*\*
- Short lay lengths

### Configurations

LFRC105-THDxUT	NPT threaded inlet x NPT female union outlet
LFRC105-PEXxPEX	PEX inlet and outlet
LFRC105-CEFxCEF	Cold expansion fitting PEX inlet and outlet (ASTM F1960)

### Specifications

**Standard Specifications:** A Water Pressure Reducing Valve with integral strainer shall be installed in the water service pipe near its entrance to the building where supply main pressure exceeds 60psi (413 kPa) to reduce it to 50psi (345 kPa) or lower. The water pressure reducing valve shall be constructed using Lead Free\* materials. Lead Free\* regulators shall comply with state codes and standards, where applicable, requiring reduced lead content. The valve shall feature a Lead Free\* cast copper silicon alloy body suitable for water supply pressures up to 300psi (20.1 bar). Provision shall be made to permit the bypass flow of water back through the valve into the main when pressures, due to thermal expansion on the outlet side of the valve, exceed the pressure in the main supply. Water Pressure Reducing Valve with built-in bypass check valves and integral strainer will be acceptable. Valve meets requirements of NSF61-G, ASSE Standard 1003 (ANSI A112.26.2), CSA Standard B356, and ASTM F877. Valve is Certified by NSF to ANSI/NSF Standard 61 Annex G. Approved valve is listed with NSF. Valve shall be a Watts Series LFRC105.

LFRC105

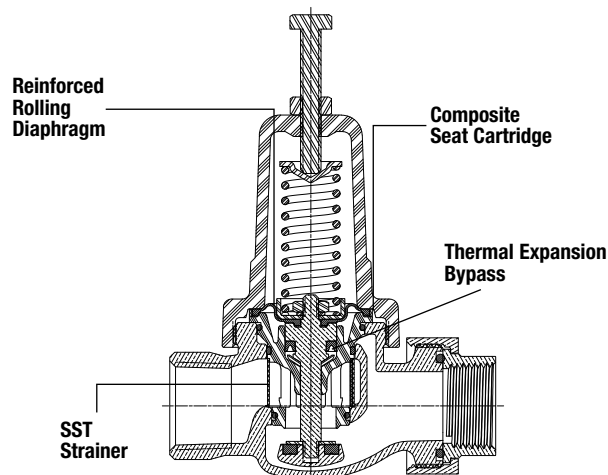

\*The wetted surface of this product contacted by consumable water contains less than 0.25% of lead by weight.

\*\*A water saving test program concluded that reducing the supply pressure from 80-50psi (551-345 kPa) resulted in a water savings of 30%.

\*\*\*The bypass feature will not prevent the pressure relief valve from opening on the hot water supply system with pressure above 150psi (10.3 bar).

### NOTICE

The information contained herein is not intended to replace the full product installation and safety information available or the experience of a trained product installer. You are required to thoroughly read all installation instructions and product safety information before beginning the installation of this product.

### NOTICE

Inquire with governing authorities for local installation requirements

Watts product specifications in U.S. customary units and metric are approximate and are provided for reference only. For precise measurements, please contact Watts Technical Service. Watts reserves the right to change or modify product design, construction, specifications, or materials without prior notice and without incurring any obligation to make such changes and modifications on Watts products previously or subsequently sold.

## Materials

Body: Lead Free\* cast copper silicon alloy  
 Seat: Engineered composite  
 Cage: Engineered composite  
 Integral Strainer: Stainless steel  
 Diaphragm: Reinforced EPDM  
 Valve Disc: EPDM

## Pressure – Temperature

Temperature Range: 33°F – 180°F (0.5°C – 82°C)  
 Maximum Working Pressure: 300psi (20.1 bar)  
 Adjustable Reduced Pressure Range: 25 – 75psi (172 – 517 kpa)  
 Standard Reduced Pressure Setting: 50psi (345 kpa)

## Capacity

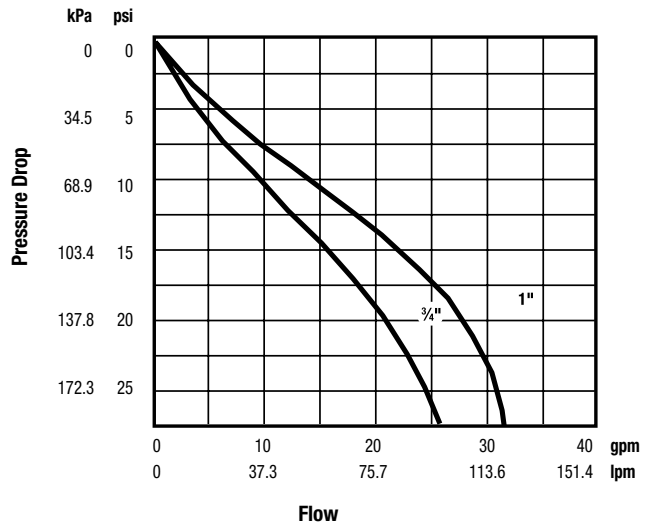

## Dimensions – Weights

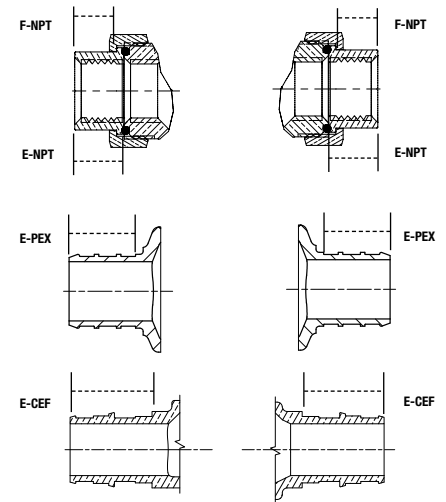
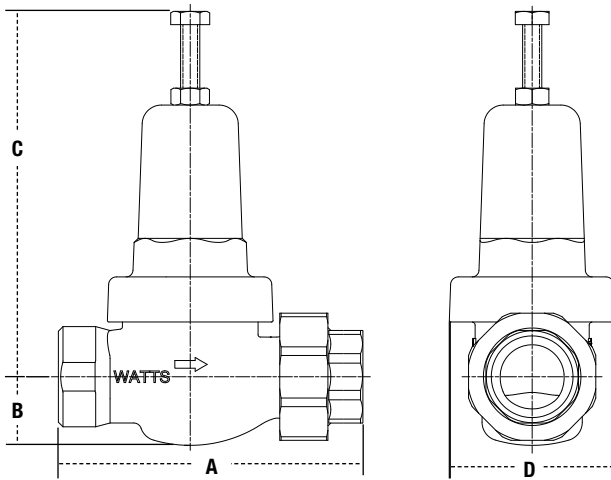

SIZE	A	A-PEX	A-CEF	B	C	D	E-PEX	E-CEF	E-NPT	F-NPT
3/4	3 15/16	3 11/16	4 3/4	7/8	4 3/4	2 1/8	5/8	15/16	5/8	1/2
1	4 11/16	4 1/16	5 1/16	7/8	4 3/4	2 1/8	13/16	1 1/4	3/4	1 1/16



USA: T: (978) 689-6066 • F: (978) 975-8350 • Watts.com  
 Canada: T: (905) 332-4090 • F: (905) 332-7068 • Watts.ca  
 Latin America: T: (52) 81-1001-8600 • Watts.com