

Installation Support • Soporte de instalación • Support d'installation

Personal Assistance, Product Specs, & "How-to" Questions:

Asistencia personal, especificaciones del producto y preguntas sobre "cómo hacerlo":

Aide personnelle, spécifications du produit et questions « pratique-pratiques » :

**1-800-PFAUCET (732-8238)**

**pfisterfaucets.com/support**

Installation Videos Available  
Videos de instalación a disposición  
Vidéos d'installation disponibles



pfisterfaucets.com/videos



**WARNING / ADVERTENCIA / AVERTISSEMENT**

To reduce the risk of injury or property damage, read all instructions before installing product. Wear safety goggles. Product must be installed in accordance with all state & local plumbing & building codes. Call a professional if you are uncertain about installing this product.

Para disminuir el riesgo de lesiones o daños a la propiedad, lea todas las instrucciones antes de instalar el producto. Utilice gafas de seguridad. El producto deberá instalarse de acuerdo con la normativa de plomería y construcción estatal y local. Llame a un profesional si no está seguro sobre cómo instalar este producto.

Pour réduire le risque de blessures ou de dommages, lire toutes les instructions avant d'installer le produit. Porter des lunettes de sécurité. Le produit doit être installé en conformité avec tous les codes de construction et de plomberie locaux et de l'état. Appelez un professionnel si vous n'êtes pas certain de la façon d'installer ce produit.

**Required Tools**

Herramientas necesarias

Outils nécessaires

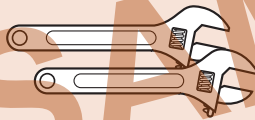

Adjustable Wrenches  
Llaves ajustables  
Clés à mollette



Safety Goggles  
Anteojos de seguridad  
Lunettes de sûreté

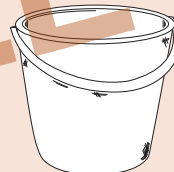

Bucket  
Balde  
Seau

**Additional Helpful Tools**

Otras herramientas útiles

Outils supplémentaires utiles

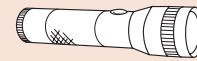

Flashlight  
Linterna  
Lampe De Poche



Cloth  
Paño de limpieza  
Chiffon

**Parts in the Box**

Piezas en la caja

Pièces dans la boîte

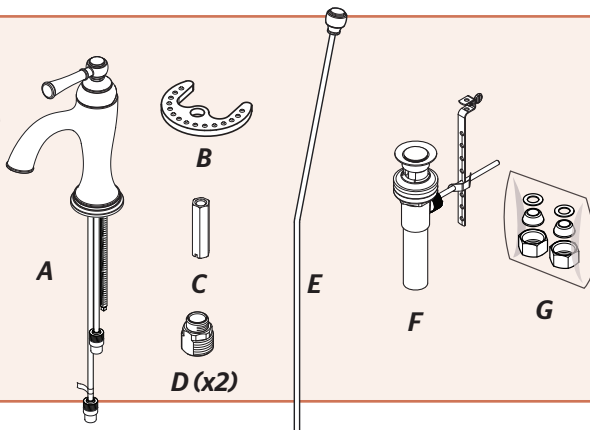

Aerator Tool  
Herramienta aireador  
Outil d'aérateur

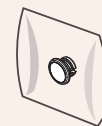

Optional Ceramic Cap  
(refer to included Flyer)  
Cubierta de Cerámica opcional  
(refiere al folleto incluido)  
Couverture Céramique option  
(voir petit livret inclus)

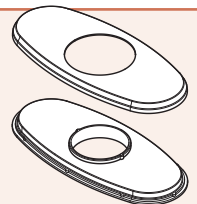

Optional Deck Plate (not included) see page 3.  
Placa de cubierta opcional (no incluido), véase la página 3.  
Plaque de pont en option (non inclus), voir page 3.

**1 Turn Off Water Supply • Cierre el suministro de agua • Couper l'alimentation en eau**



Locate water supply inlets and shut off the water supply valves. These are usually found under the sink or near the water meter. If you are replacing an existing faucet, remove the old faucet from the sink and clean the sink surface thoroughly.

Ubique las entradas del suministro de agua y cierre las válvulas de suministro de agua. Generalmente se encuentran debajo del fregadero o cerca del medidor de agua. Si se trata de un reemplazo de grifo, quite el grifo viejo y limpie completamente la superficie del fregadero.

Recherchez les entrées d'approvisionnement et fermer leurs robinets. Ces robinets se trouvent généralement sous l'évier ou près du compteur d'eau. Si vous remplacez un robinet existant, retirez, le vieux robinet de l'évier et nettoyer soigneusement la surface de ce dernier.

Hot  
Caliente  
Chaud

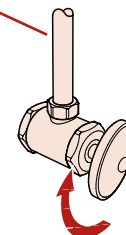

Cold  
Fría  
Froid

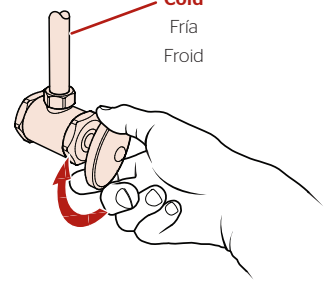

## 2

### Install Faucet **without Deckplate**

Instale el grifo sin la placa de cubierta

Installer le robinet sans le plate-forme

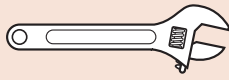

Adjustable Wrench  
Llave ajustable  
Clé réglable

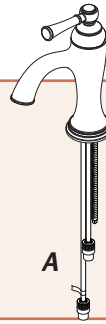

A

B

C

2A

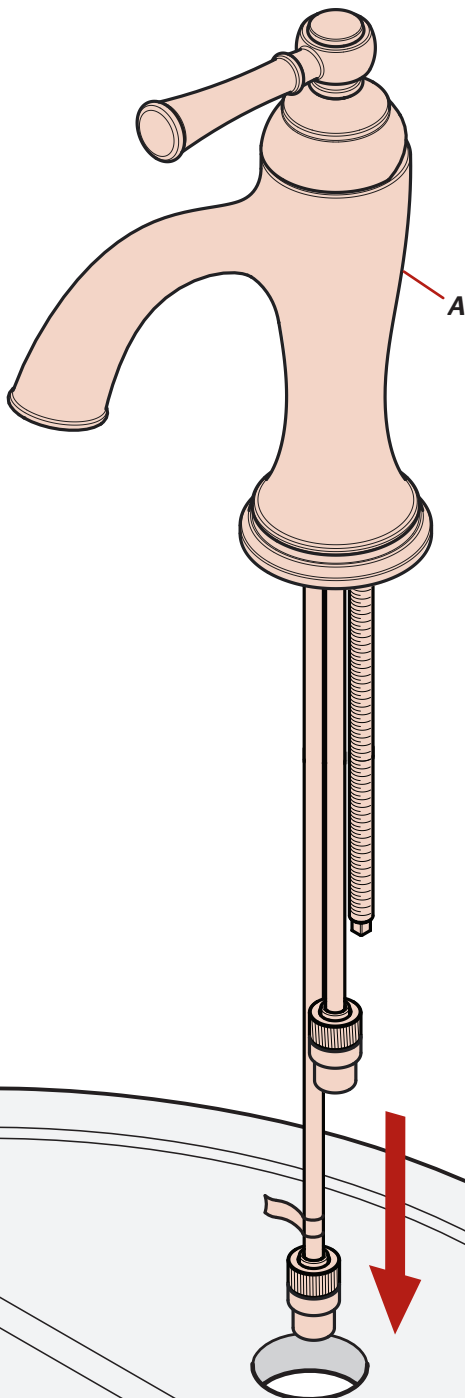

2B

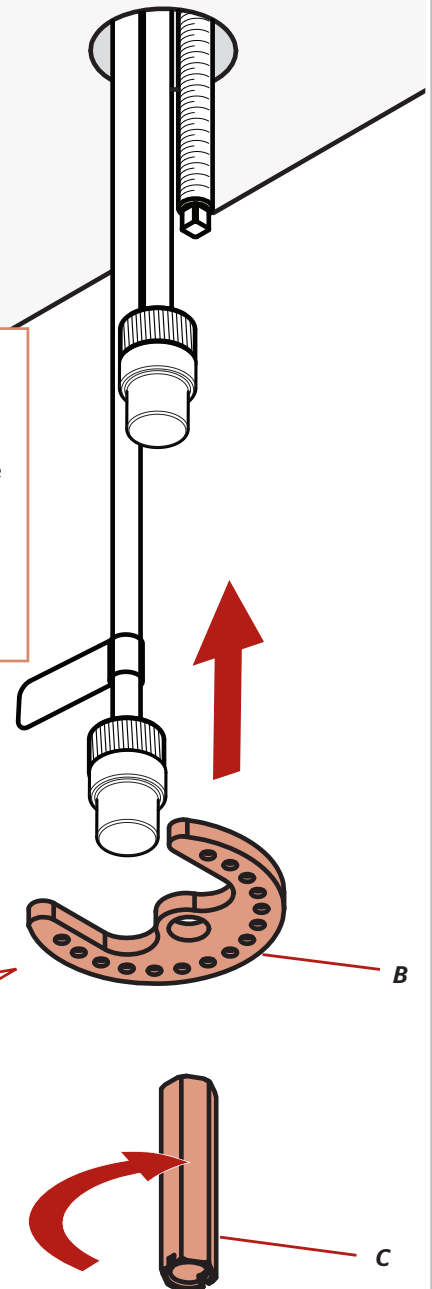

**Be sure the spout body (A) is centered & facing forward.  
IMPORTANT: DO NOT OVERTIGHTEN.**

Cerciórese que la estructura del surtidor (A) esté centrada y orientada hacia adelante.  
IMPORTANTE: NO APRIETE EXCESIVAMENTE.

Assurez-vous que le corps du bec (A) est centré et tourné vers l'avant.  
IMPORTANT: NE PAS TROP SERRER.

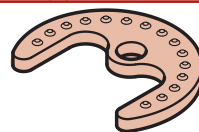

**Bumps face up.**  
Topa cara arriba.  
Cogne récepteur.

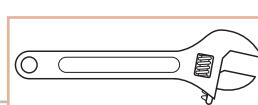

## 2

**OPTION: Install Faucet with Deckplate**

**OPCIÓN: Instale el grifo con la placa de cubierta**

**OPTION: Installer le robinet avec le plate-forme**

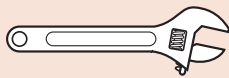

Adjustable Wrench  
Llave ajustable  
Clé réglable

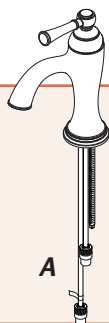

A



B



C

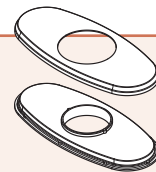

**Optional Deck Plate (not included)**  
Placa de cubierta opcional (no incluido).  
Plaque de pont en option (non inclus).

### 2A

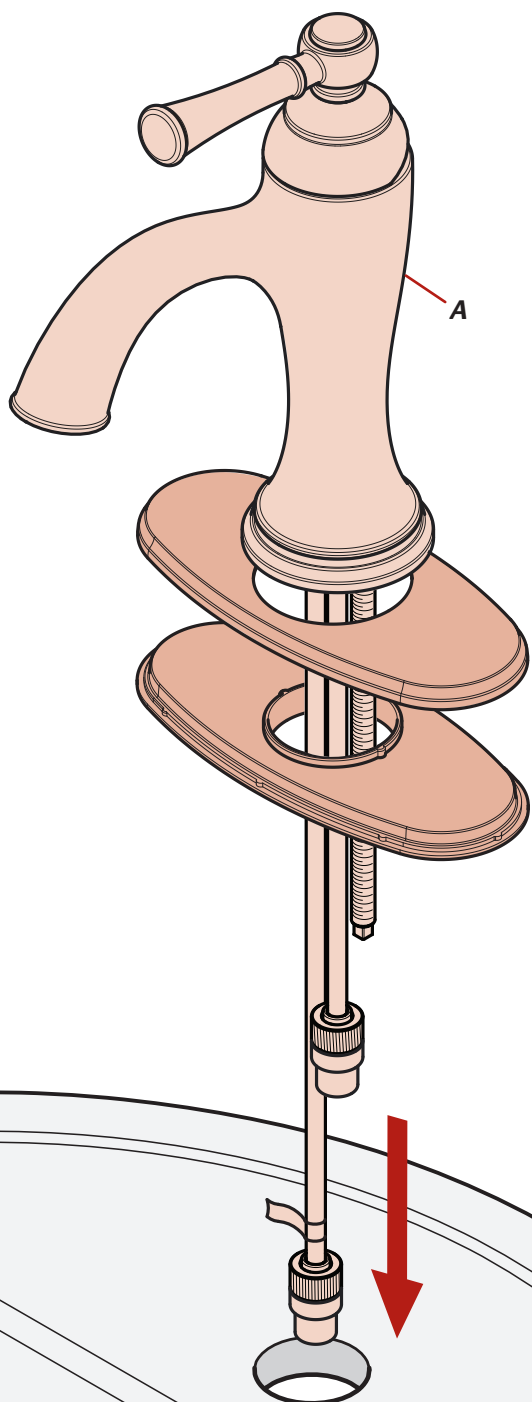

### 2B

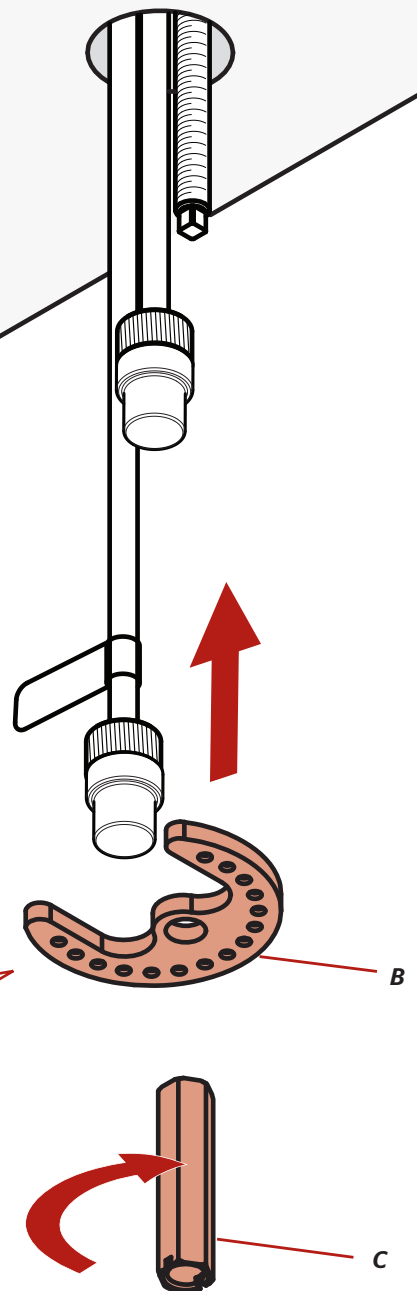

Optional Deck Plate, see Maintenance & Care Guide, page 2, Call 1-800-732-8238 to order.

Placa de cubierta opcional, consulte la Guía de Mantenimiento y Cuidado de la página 2, llame al 1-800-732-8238 para ordenar.

Plaque de pont en option, consultez le Guide de maintenance et d'entretien, page 2, Appelez 1-800-732-8238 à l'ordre.



**Be sure the spout body (A) is centered & facing forward.  
IMPORTANT: DO NOT OVERTIGHTEN.**

Cerciórese que la estructura del surtidor (A) esté centrada y orientada hacia adelante.  
IMPORTANT: NO APRIETE EXCESIVAMENTE.

Assurez-vous que le corps du bec (A) est centré et tourné vers l'avant.  
IMPORTANT: NE PAS TROP SERRER.

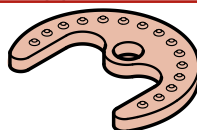

**Bumps face up.**  
Topa cara arriba.  
Cogne récepteur.

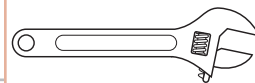

### 3 Connect Water Supply Lines

Conecte las tuberías de suministro de agua  
Raccorder les conduites d'alimentation en eau

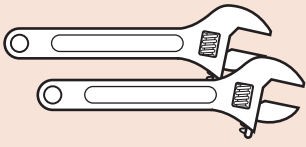

Adjustable Wrenches  
Llaves ajustables  
Clés à molette

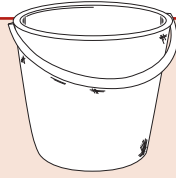

Bucket  
Balde  
Seau



D (x2)



**Water Supply Lines not included. Please consult manufacturer and/or its instructions for the correct method of installation of supply lines & fittings.**

**IMPORTANT: Incorrect application of supply lines and fittings may result in the failure or leak of the supply lines and fitting.**

Las tuberías de suministro de agua no están incluidas. Consulte por favor el fabricante y/o sus instrucciones para el método correcto de instalación de líneas de suministro y de guarniciones.

**IMPORTANT:** El uso incorrecto de líneas de suministro y de guarniciones puede dar lugar a la falta o al escape de las líneas de suministro y de la guarnición.

Les tuyaux d'arrivée d'eau ne sont pas fournis. Veuillez consulter le fabricant et/ou ses instructions pour la méthode correcte d'installation des conduites d'alimentation en eau et des accessoires.

**IMPORTANT:** Mauvaise application des lignes d'alimentation et accessoires peut entraîner la défaillance ou la fuite.

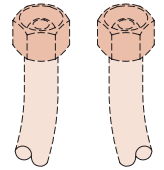

**HOT**  
CALIENTE  
CHAUD

**COLD**  
FRÍA  
FROID

3A

#### Point Lines in Bucket

Guiar las Líneas hacia el Balde  
Guide les lignes en le Balde

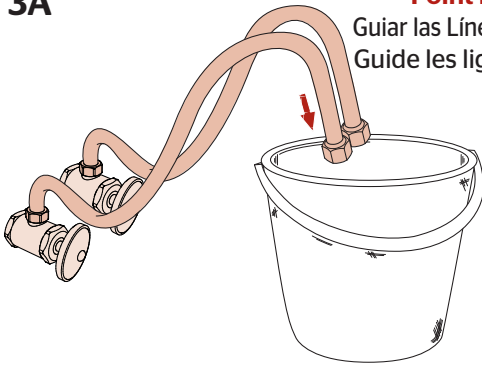

3B

#### Turn On Water

Active el suministro de agua  
Ouvrez l'eau

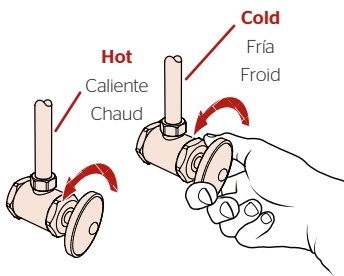

3C

#### Flush Lines

Enjuagar las Líneas  
Rincer les Lignes

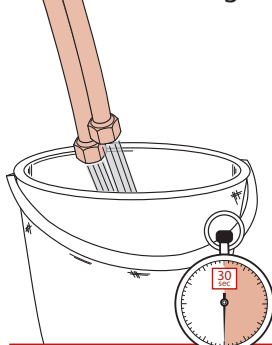

**Allow water to run for at least 30 seconds.**

Deje correr el agua durante al menos 30 segundos.  
Permettez à l'eau couler au moins 30 secondes.

3D

#### Turn Off Water Supply

Cierre el suministro de agua  
Couper l'alimentation en eau

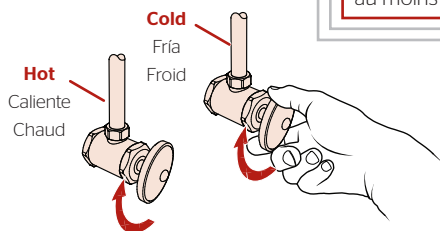

3E

x2

**Hot & Cold**  
Caliente y fría  
Chaud et froid

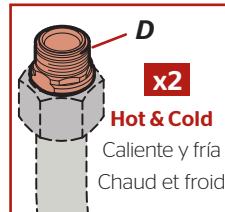
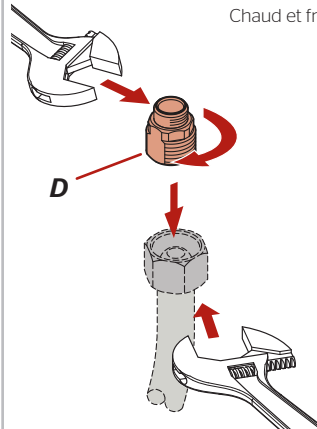

3G



**Separate tubes gently and slightly for clearance.**

Tubos separados y ligeramente suavemente para su despacho.

Tubes séparés doucement et légèrement pour le dédouanement.

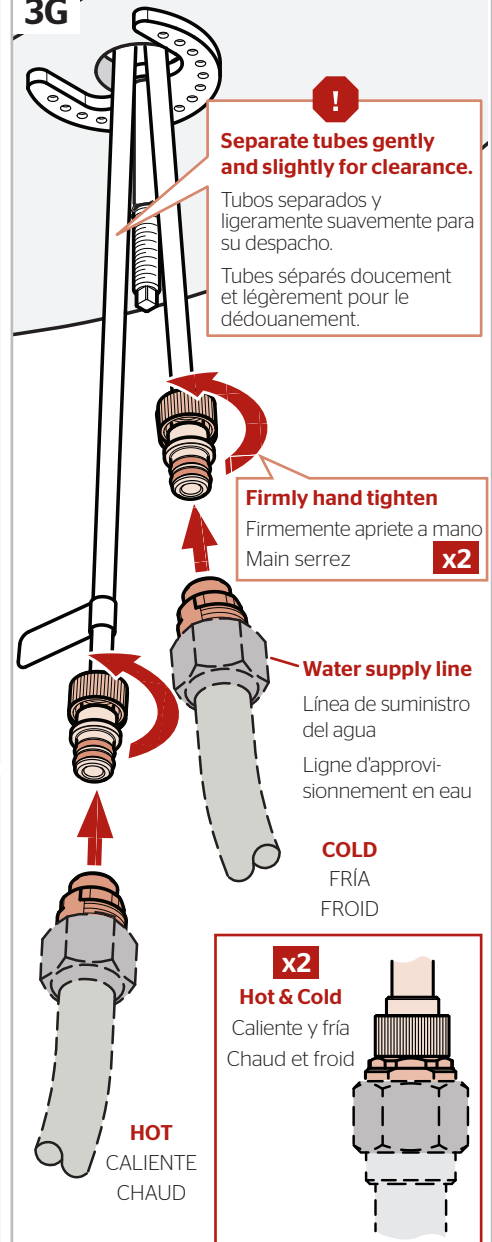

3F

x2

**Hot & Cold**  
Caliente y fría  
Chaud et froid

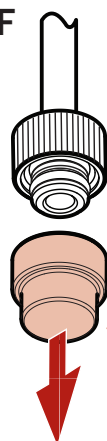

**Package Only**  
Empaquetado solamente  
Empaquetage seulement

x2

**Hot & Cold**  
Caliente y fría  
Chaud et froid

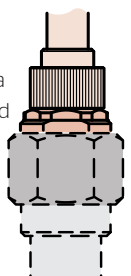

## 4 Prepare & Install Pop-Up

Prepare e instale el tapón retráctil

Préparez & installez le bouchon à clapet

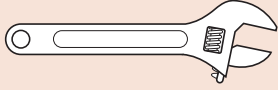

Adjustable Wrench  
Llave ajustable  
Clé réglable

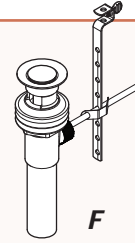

4A

### Disassemble Pop-up Assembly

Desensamble el ensamble del tapón retráctil

Démontez l'ensemble bouchon à clapet

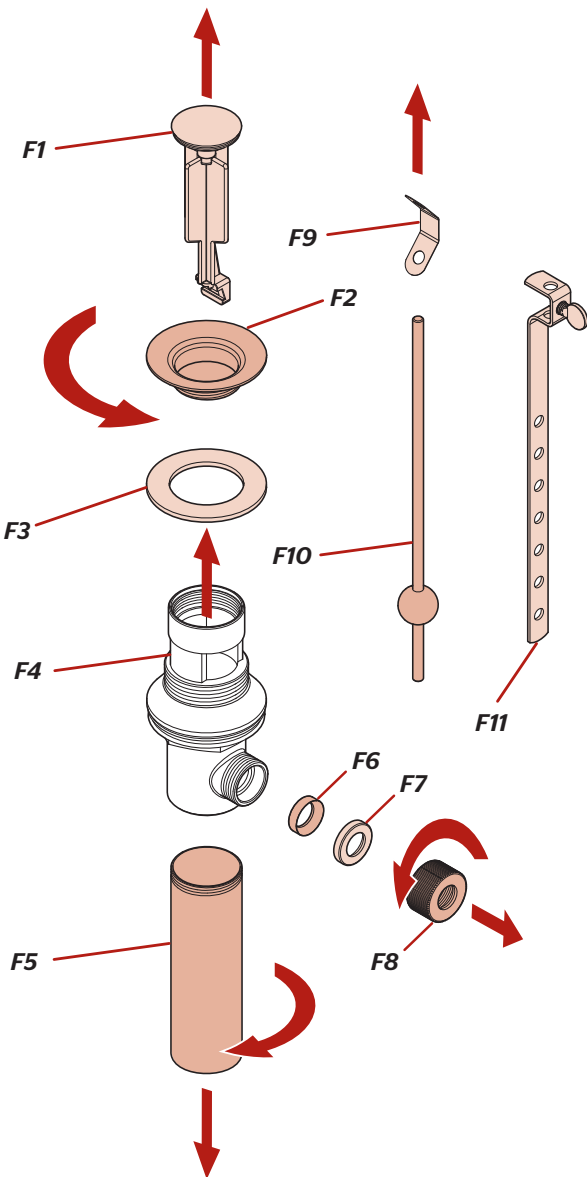

4B

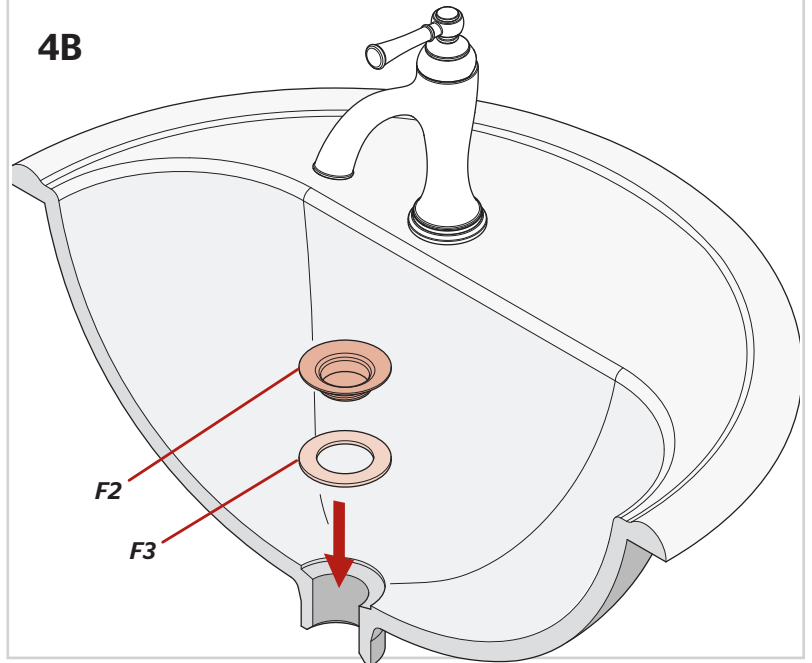

4C

**Thread Drain Body (F4) to bottom of Flange (F2) and adjust so that Ball Rod opening faces rear.**

Enrosque la estructura de desagüe (F4) a la parte inferior de la pestaña (F2) y ajuste de modo que la abertura de la varilla con glóbulo esté orientada hacia la parte posterior.

Vissez le corps du renvoi (F4) au bas de la bride (F2) et réglez de façon que l'ouverture de la tige soit tournée vers l'arrière.

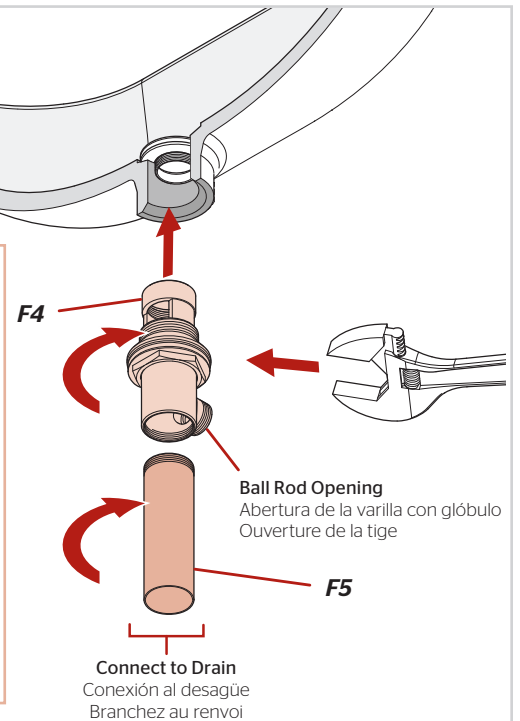

**Connect to Drain**  
Conexión al desagüe  
Branchez au renvoi

## 5 Prepare & Connect Lift Rod

Prepare y conecte la varilla de elevación

Préparez & connectez la tige levier

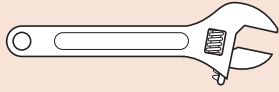

Adjustable Wrench  
Llave ajustable  
Clé réglable

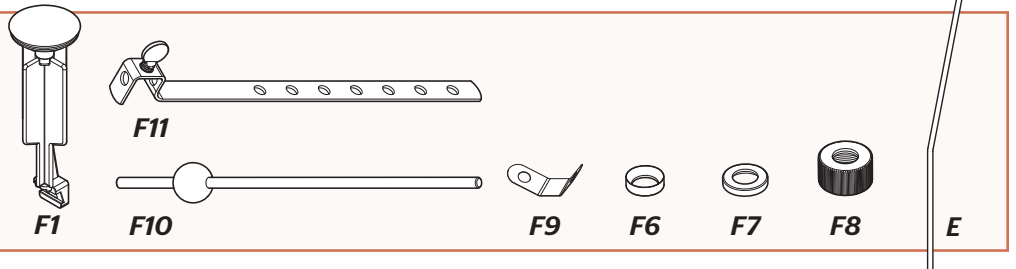

5A

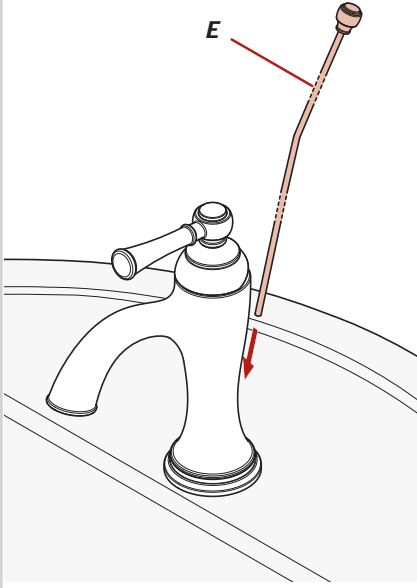

5B

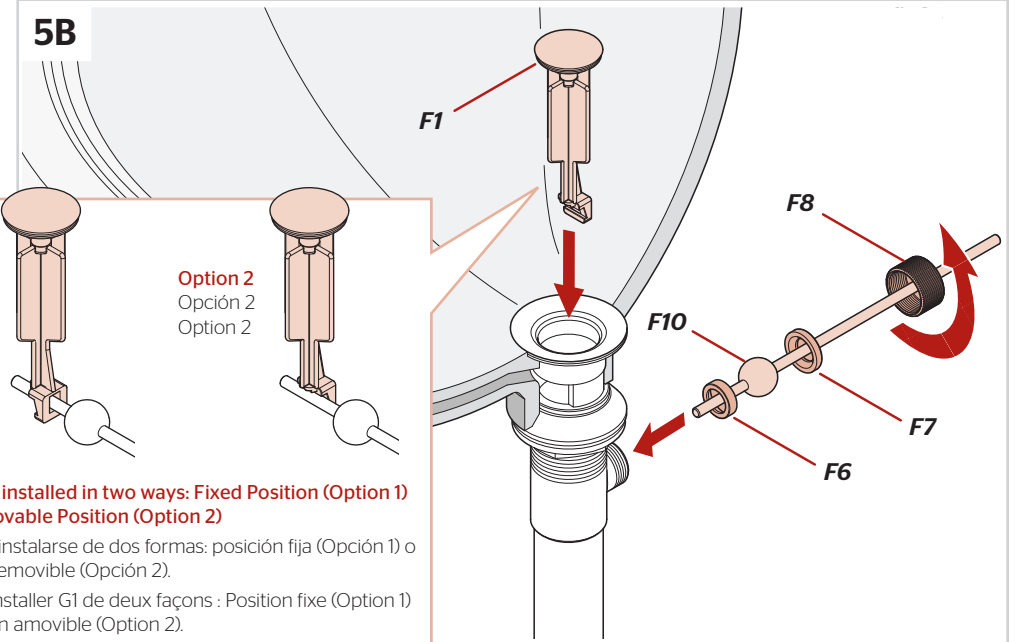

5C

### Assemble Lift Rod Connection

Ensamble de la conexión de varilla de elevación

Assemblez la connexion de la tige levier

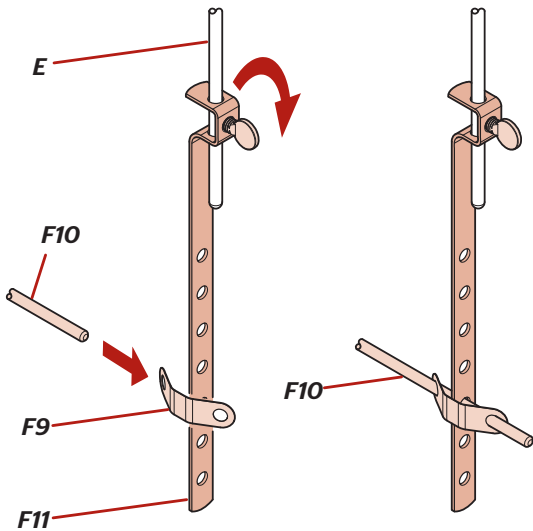

5D

### Pop-Up Completion

Terminer le bouchon à clapet

Finalización de la instalación del tapón retráctil

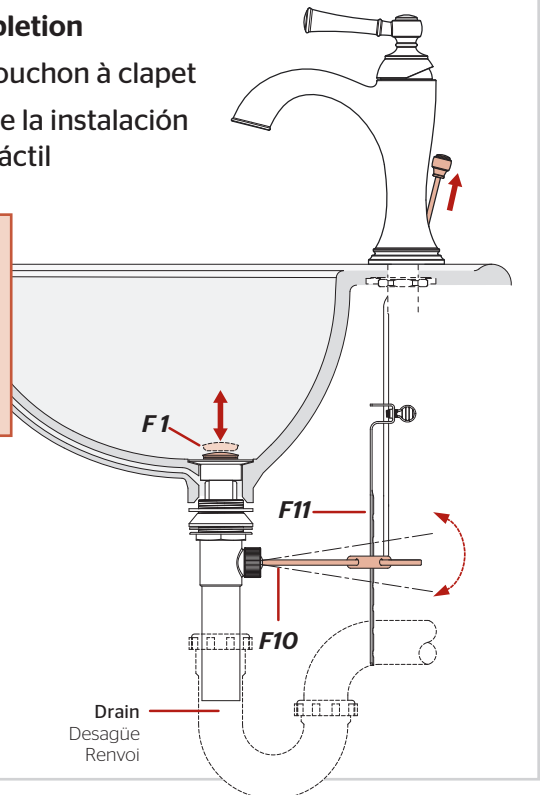
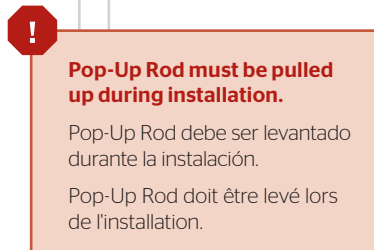

## 7 Turn On Water & Confirm Proper Installation

Active el suministro de agua y confirme que la instalación está adecuadamente efectuada

Ouvrez l'eau et confirmez que l'installation est correcte

7A

**Hot**  
Caliente  
Chaud

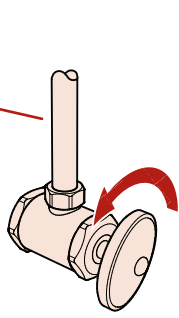

**Cold**  
Fría  
Froid

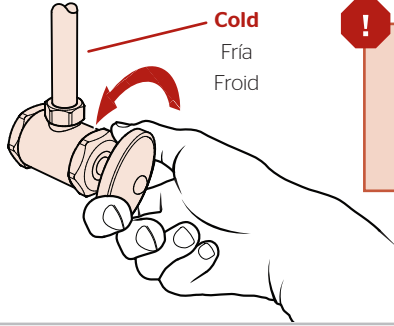

**Check for leaks above and below the sink.**

Revise si hay fugas encima y debajo del fregadero

Assurez-vous qu'il n'y a pas de fuite au dessus ou au dessous du lavabo.

## 8 Faucet Function

Funciones del grifo

Fonctionnement du robinet

8A

**Open**  
Abierta  
Ouvverte

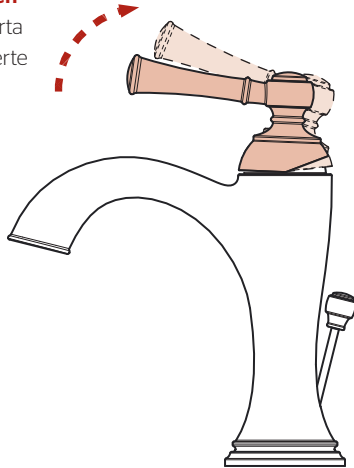

**Faucet Function**  
Funciones del grifo  
Fonctionnement du robinet

**Hot**  
Caliente  
Chaud

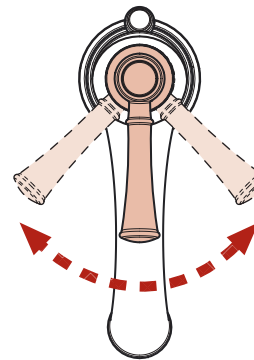

**Cold**  
Fría  
Froid

## 9 Flush the Faucet

Enjuague el grifo

Vidanger l'robinet

**9A Remove Aerator**  
Retire el aereador  
Retirez l'aérateur

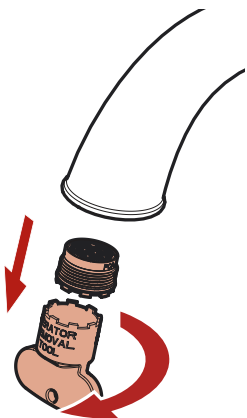

**9B**

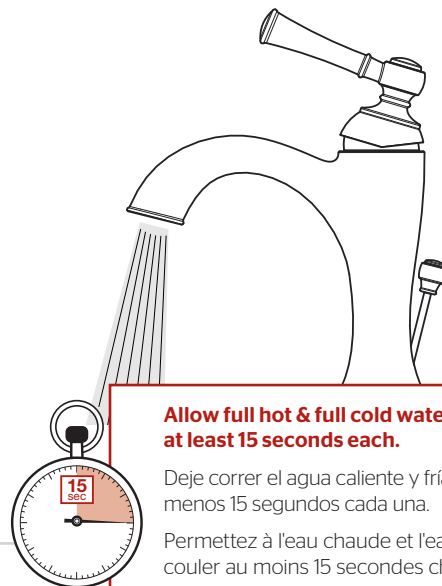

**Allow full hot & full cold water to run for at least 15 seconds each.**

Deje correr el agua caliente y fría durante al menos 15 segundos cada una.

Permettez à l'eau chaude et l'eau froide de couler au moins 15 secondes chacun.

**9C Reinstall Aerator**  
Reinstale el aereador  
Réinstallez l'aérateur



**Hand Tighten**

Apriete con la mano

Serrez manuellement



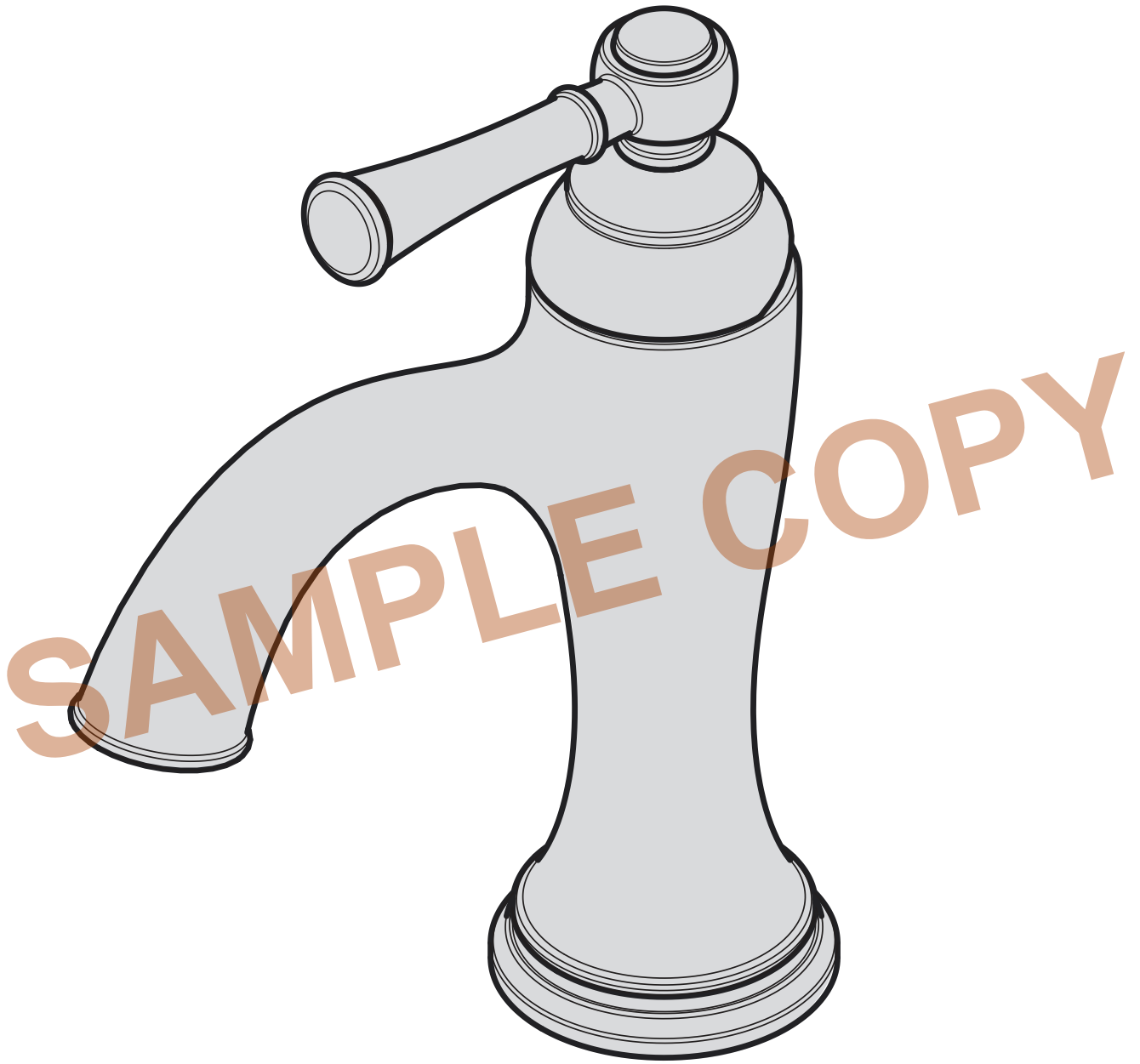

**For Additional Installation Help:**  
Para la instalación adicionales de ayuda:  
Pour les aides supplémentaires à l'installation:

**PfISTER**<sup>®</sup>

**1-800-PFAUCET (732-8238)**  
**[pfisterfaucets.com](http://pfisterfaucets.com)**