



Fresh Air Ventilation

Product Guide



Aprilaire sets the standard for residential fresh air ventilation with whole-home solutions based on building and energy codes, geographic climate zones and cost-effective installations.

Trusted Solutions for a Healthy Home®

Aprilaire fresh air ventilation

Aprilaire provides HVAC contractors with a comprehensive lineup of whole-home, fresh air ventilation products for every geographic climate zone and application. Our expanded lineup features new products and upgraded controls that make installing and managing ventilation in multiple applications (single-family, multi-family, light commercial) easier and more effective than ever before.

Comfort and Health

- + “The U.S. Environmental Protection Agency (EPA) studies of human exposure to air pollutants indicate that indoor levels of pollutants may be two to five times—and occasionally more than 100 times—higher than outdoor levels.”
<https://www.epa.gov/iaq-schools/why-indoor-air-quality-important-schools>
- + Whole-home ventilation introduces fresh air into the home to combat these pollutants and prevent stale odors and stagnant air from impacting the living space of the home.

Efficiency

- + Many successful builders use energy-efficient construction materials to differentiate their businesses. These tighter-built homes increase the need for fresh air delivery to the living space.
- + Aprilaire’s new ventilation controller allows for high and low temperature and relative humidity lockouts. Superior control and operation allow our fresh air ventilators to deliver fresh air efficiently and reliably.

Building and Energy Codes

- + Ventilation controller meets ASHRAE 62.2-2010.
- + Fresh air ventilators meet IECC 2012 & 2015 codes and California Energy Commission Title 24.

Ventilation optimized per temperature lockouts and ventilation code

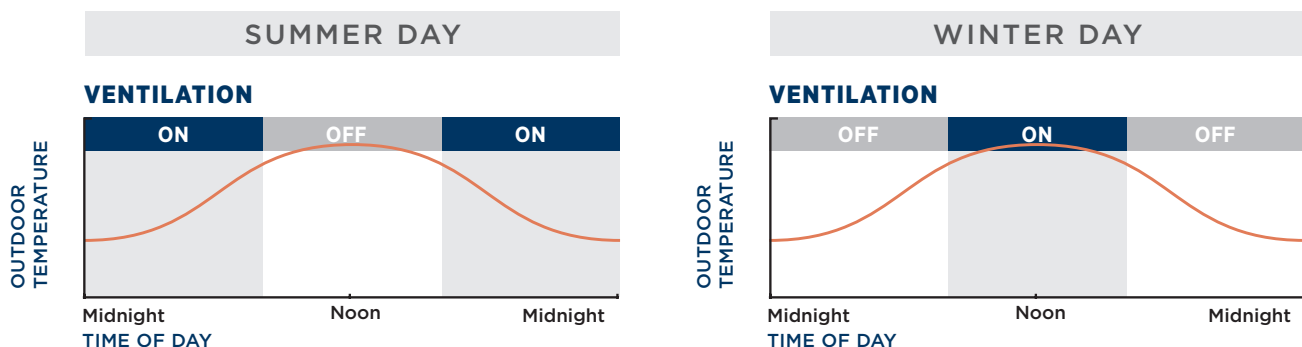

Charts above are for illustration purposes.

Whole-home benefits of fresh air ventilators

Single-point ventilation is commonly used to remove moisture from specific areas such as bathrooms. However, exhaust fans and range hoods are not effective in exchanging stale air throughout the entire home.

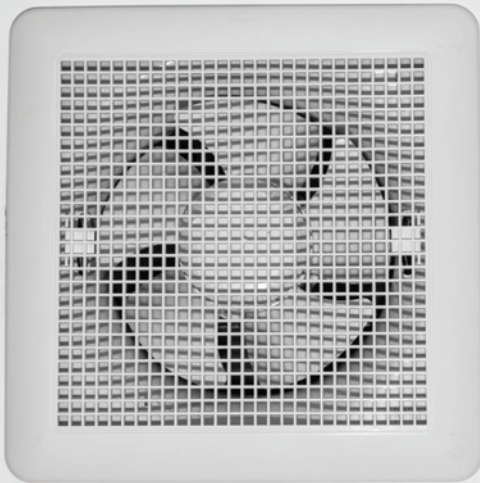

Single-point ventilation is NOT the answer.

“Exhaust ventilation testing showed lower uniformity of outdoor air exchange rate between living space zones, and higher concentrations of particulates, formaldehyde, and other top 20 VOCs than did the supply and balanced ventilation systems. This showed that **single-point exhaust ventilation was inferior as a whole-home ventilation strategy** because the source of outside air was not directly from outside (much of it came from the attic), the ventilation air was not distributed, and no provision existed for air filtration.”

US Department of Energy – Ventilation System Effectiveness and Tested Indoor Air Quality Impacts – February 2014

BATH FAN	WHOLE-HOME VENTILATION
Removes moisture from a specific area of the home.	Removes moisture from the entire home.
Does not deliver fresh outdoor air into the home.	Delivers fresh outdoor air into the home.
Homeowner has to manually operate bath fan to start ventilation.	Ventilation is set and automated from thermostat or vent controller.
Does not effectively combat particulates, formaldehyde and other VOCs in the air.	Effective solution against particulates, formaldehyde and other VOCs in the air.
Ventilation is impacted if bathroom door is closed.	Ventilation is not impacted if bathroom door is closed.

Fresh air delivered through the HVAC system

When ventilation is a part of a home's HVAC system, the required amount of fresh air is delivered to the home at the lowest cost to the consumer. Below are some of the many advantages that whole-home ventilation provides over single-point ventilation.

WHOLE-HOME COVERAGE

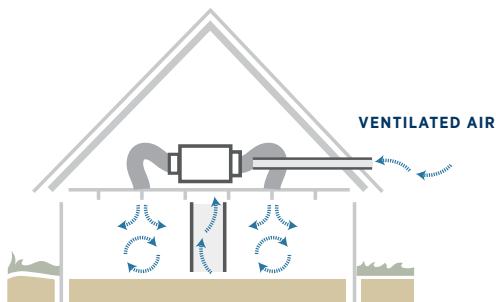

Aprilaire ventilators utilize existing HVAC ducting systems to deliver air throughout the home.

CONTROLLED AIR SOURCE

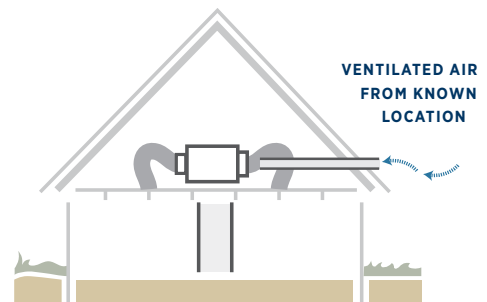

Outdoor air is delivered from a safe location, not passing through the walls.

AIR PRE-CONDITIONED

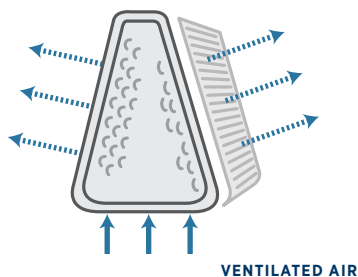

Ventilated air is delivered to the air conditioning evaporator coil to remove moisture.

POSITIVE PRESSURE

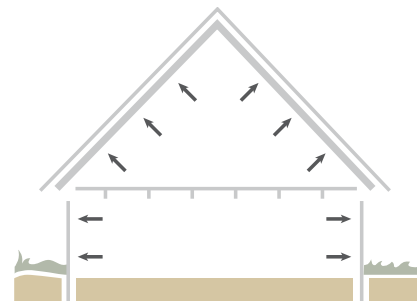

Positive pressure eliminates safety concerns from combustible appliances backdrafting and is easy to measure (CFM).

Fresh air ventilation for all applications

Homes with any type of HVAC system can easily be equipped with Aprilaire fresh air ventilators.

Multiple installation applications, including

+ BASEMENT

+ CRAWLSPACE

+ GARAGE

+ ATTIC

+ CLOSET

Industry-leading ventilation control

The new Aprilaire 8120X Ventilation Control makes every fresh air ventilator efficient and effective with intelligent operation.



- + Easy, intuitive setup menu helps installers calculate required CFM of fresh air needed per hour to satisfy ASHRAE Standard 62.2-2010 requirements.
- + Patented control logic uses ASHRAE 62.2 code even with temperature lockouts in place (ventilator will stay on for longer periods of time to meet requirements when temperatures are within acceptable range).^{**}

**Pat. No. 9,874,366 **Also found in 8620, 8620W, 8910, 8910W and 8920W*

- + With just the press of a button, raters can easily determine how much continuous or intermittent CFM is being delivered.
- + Ventilation can be set up with homeowner's comfort in mind by setting high and low outdoor air temperature lockouts as well as high and low indoor air relative humidity lockouts.



Ventilation climate zones

Managing the quality of ventilated air delivered into the home is critical to providing a healthy indoor environment. The requirements change significantly based on climate. Aprilaire ventilation solutions work with the HVAC equipment to remove moisture, harmful particulates and other contaminants such as VOCs. It's critical to use intelligent ventilation controls and application guidance to properly ventilate rather than relying on exhaust ventilation which simply pulls air through walls.

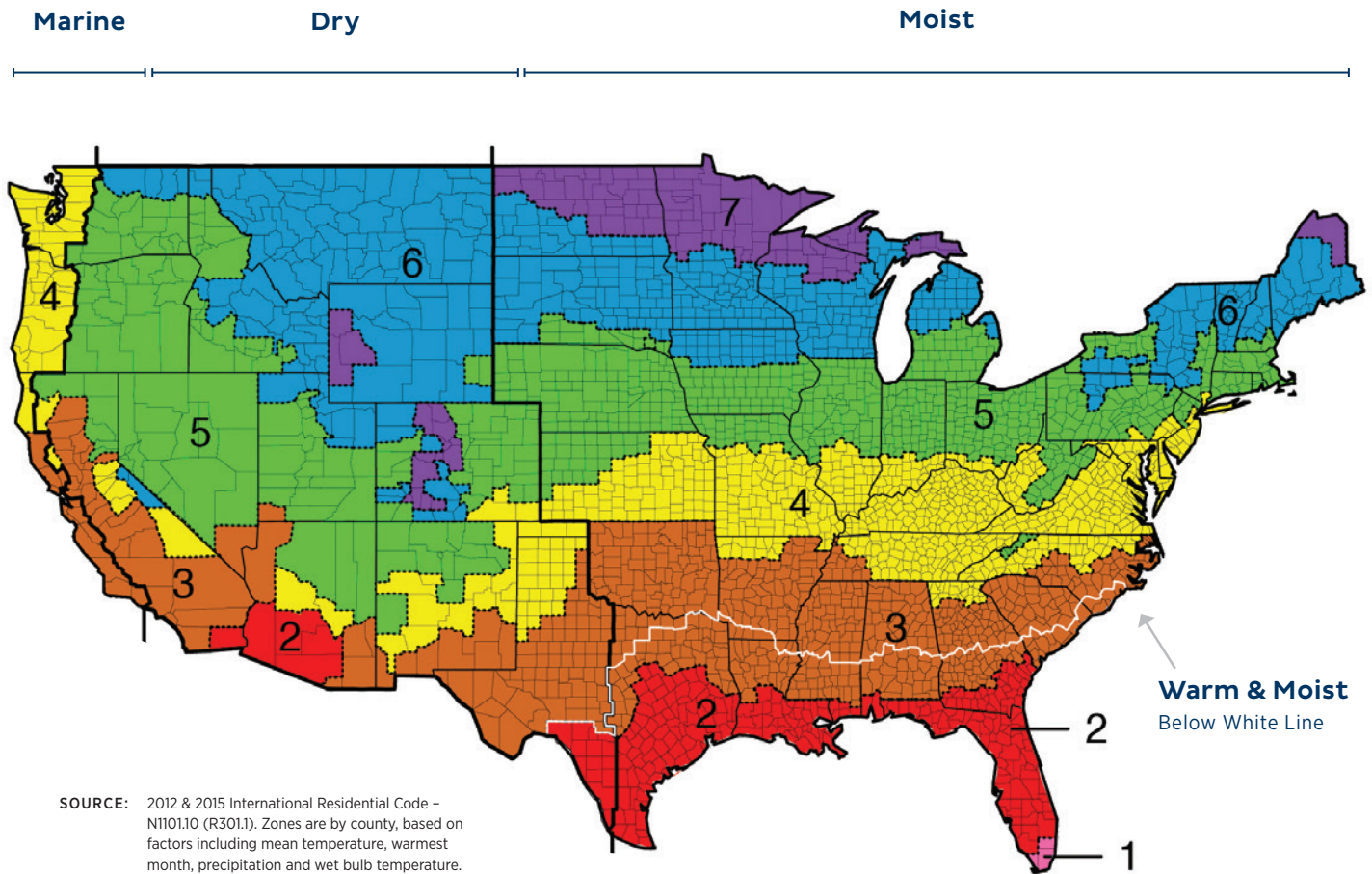

Use this map and the adjoining application guide to determine the recommended product solution for your climate. These recommendations are based on moisture removal demands, energy savings and integration with the HVAC equipment.

ZONE	CLIMATE TYPE	MAJOR CITIES	PRIMARY SOLUTION ¹	FRESH AIR DUCTED ²	ECONOMY- OR COMFORT-FOCUSED SOLUTION	MULTI-FAMILY NEW CONSTRUCTION SOLUTION
1	Hot & Moist	Miami	8191 or 8192 Dehumidifies incoming ventilation air	HVAC Return	8140 or 8126X	8144NC
2	Hot & Moist	Orlando, Mobile, New Orleans, Houston, Austin, San Antonio	8191 or 8192 Dehumidifies incoming ventilation air	HVAC Return	8140 or 8126X	8144NC
2	Hot & Dry	Phoenix, Tucson	8142 Mixes ventilation air after cooling or heating	HVAC Supply	8126X	8144NC
3	Warm & Moist	Charlotte, Charleston, Atlanta, Little Rock, Oklahoma City, DFW	8191 or 8192 Dehumidifies incoming ventilation air	HVAC Return	8140 or 8126X	8144NC
3	Warm & Dry	El Paso, Las Vegas, Los Angeles, Sacramento	8142 Mixes ventilation air after cooling or heating	HVAC Supply	8126X	8144NC
3	Warm & Marine	San Francisco, San Jose	8142 Mixes ventilation air after cooling or heating	HVAC Supply	8140 or 8126X	8144NC
4	Mixed & Moist	Philadelphia, Washington DC, Baltimore, Nashville, St. Louis, Wichita, Louisville	8140 Mixes ventilation air prior to cooling or heating	HVAC Return	8191, 8192 or 8126X	8144NC
4	Mixed & Dry	Albuquerque, Amarillo	8142 Mixes ventilation air after cooling or heating	HVAC Supply	8140 or 8126X	8144NC
4	Mixed & Marine	Portland, Seattle	8142 Mixes ventilation air after cooling or heating	HVAC Supply	8140 or 8126X	8144NC
5	Cool & Moist	Boston, Pittsburgh, Columbus, Indianapolis, Detroit, Chicago, Des Moines, Omaha	8140 Mixes ventilation air prior to cooling or heating	HVAC Return	8126X	8144NC
5	Cool & Dry	Denver, Salt Lake City, Boise, Reno	8140 Mixes ventilation air prior to cooling or heating	HVAC Supply or Return	8142 or 8126X	8144NC
6	Cold & Moist	Toronto, Vancouver, Milwaukee, Madison, Minneapolis-St Paul, Sioux Falls	8140 Mixes ventilation air prior to cooling or heating	HVAC Return	8126X	8144NC
6	Cold & Dry	Helena, Cheyenne	8140 Mixes ventilation air prior to cooling or heating	HVAC Return	8126X	8144NC
7	Extreme Cold & Moist	Fargo, Duluth, Calgary, Edmonton	8140 Mixes ventilation air prior to cooling or heating	HVAC Return	8126X	8144NC

¹ Primary Aprilaire recommended supply ventilation solution for optimal performance and building code adherence.

² HVAC application considerations based upon moist versus dry air, and proper mixing into the ductwork.

Fresh Air Ventilator

With Dehumidification

Model 8191/8192 | Specification Sheet

SPECIFICATIONS AND SIZING SUMMARY

MODEL	8191	8192
Nominal ventilation airflow	100 CFM	200 CFM
Capacity ⁽¹⁾ pints/day	70 ppd	95 ppd
Energy factor ⁽¹⁾	1.91 L/kW-h	2.2 L/kW-h
Energy Star qualified	Yes	No
Air flow @ various external static pressure - dry coil		
0.0" w.c.	160 CFM	265 CFM
0.2" w.c.	120 CFM	230 CFM
0.4" w.c.	70 CFM	200 CFM
Voltage, phase, frequency	120VAC, 1, 60 Hz	
Current draw ⁽¹⁾	6.3 amps	8.0 amps
Sound level	47 dBA ducted	54 dBA ducted
	51 dBA unducted	
Dimensions - cabinet only		
Width	12½"	12½"
Height ⁽²⁾	14½"	14½"
Length	25"	27½"
Weight	70 lbs.	75 lbs.
Operating condition		
Inlet air operating conditions	50°F–104°F, 40°F dew point min.	
Ambient/ventilation	40°F–140°F, 0%–99% RH	

⁽¹⁾ Rated capacity and Energy Factor test done and current draw measure in accordance with AHAM DH-1 2008 at 80°F/60%RH inlet air at 0.0 ESP.

⁽²⁾ Height does not include adjustable feet or casters. The width excludes the filter doors, and length excludes the duct collars.

SPECIFICATIONS

Control	Built-in digital control with display
Control mounting option	Field interchangeable from top to front
Cabinet insulation	½" EPS
Air discharge orientation	Top or end air discharge
Inlet/outlet duct collars	10" round
Back damper at outlet	Included
Air filter	Washable MERV 8
Refrigeration	R-410A
Coil type	E-coated
8' Power cord type	Plug type
Drain connection	¾" PVC adapters ⁽¹⁾
Warranty	5 Years

⁽¹⁾ Thread adapter and barbed fitting for clear drain tubing included.



FEATURES

- + Removes moisture from outdoor air before it enters the living space
- + Unit is designed, when properly installed, to achieve ASHRAE Standard 62.2-2010
- + Integral moisture and ventilation control
- + Optional ventilation control via thermostat (see below)
- + High and low temperature limit lock-outs

RECOMMENDED CONTROLS

- + Aprilaire Thermostat Models
 - 8620, 8620W
 - 8910, 8910W
 - 8920W
- + Aprilaire Communicating Thermostat Models
 - 8820
 - 8830
 - 8840

BENEFITS

- + Helps control RH in the home during periods when the air conditioning system does not run long enough to remove sufficient moisture. If air conditioner can satisfy RH requirements, the Aprilaire unit's compressor shuts off
- + Optimize energy savings by locking out ventilation during hottest/coldest times of the day
- + Improves indoor air quality
- + Installation temperature range up to 140°F
- + Installation labor reduced, requires only a power outlet and 24-volt wiring to HVAC system

When properly installed and set, the Aprilaire Model 8191 and Model 8192 ventilators with dehumidification will meet the mechanical ventilation requirements of:

- + Energy Star Certified Homes, Version 3
- + EPA Indoor airPLUS, Version 1
- + 2012 & 2015 International Residential Code (IRC)
- + 2012 & 2015 International Energy Conservation Code (IECC) – 8191 Only

Fresh Air Ventilators

With Powered Damper & Filter

Model 8140, 8140NC | Specification Sheet

SPECIFICATIONS

Overall dimensions	14 $\frac{3}{8}$ " W x 11 $\frac{3}{8}$ " H x 27 $\frac{3}{8}$ " L
Inlet collar	6" Round
Outlet collar	6" Oval
Ventilation setting	Off, 6–60 min/hr Code/Comfort Operation
Ambient temperature	0°F – 140°F
Outdoor temperature limits	Low: -10°F–40°F High: 85°F–105°F
Indoor RH limits	Low: 10–30% High: 45–70%
Voltage	115VAC, 1 phase, 60 Hz
Power	Includes 5' power cord
Ducting	6" dia. flexible insulated duct
Warranty	5 Years
ETL	Tested to UL Standard 705 Not for outdoor use

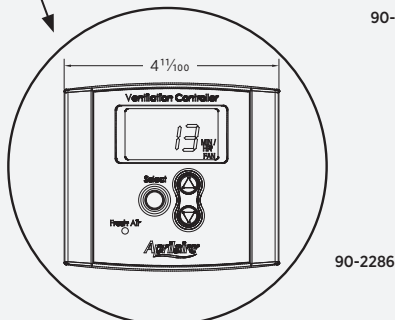
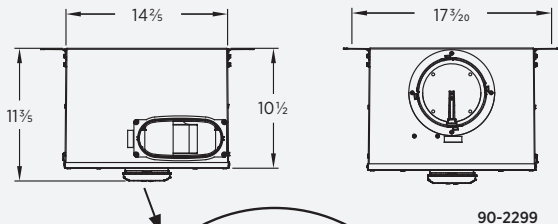
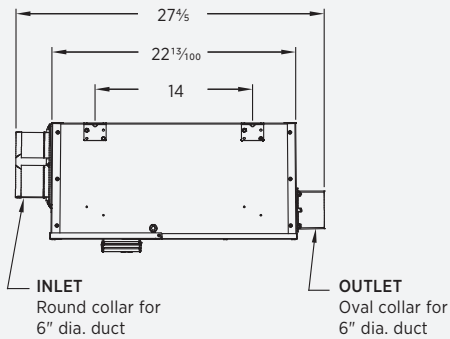

8140



8140NC

FEATURES

- + Control is integrated into the Model 8140 Ventilator. The Model 8140NC has no integrated control so the ventilator can be hardwired to the HVAC system and controlled from within the living space.
- + High and low outdoor temperature limit lock-outs while maintaining ASHRAE Standard 62.2-2010 (Model 8140 only)
- + High and low indoor relative humidity (RH) limits can be set on the controller (Model 8140 only)
- + Patented logic adjusts on-time and cycle time to meet ventilation requirements within set temp and RH ranges (Model 8140 only)*
- + Integrated powered damper
- + Removable, washable filter

BENEFITS

- + Delivers the precise amount of outside air needed in today's efficiently designed homes
- + Model 8140 optimizes energy savings by locking out ventilation during hottest/coldest times of the day
- + Improves indoor air quality
- + Robust design handles hot attics up to 140°F
- + Installation labor reduced, requires only a switched outlet and 24-volt wiring to HVAC system
- + Furnace or air handler does not require an ECM motor to meet efficacy requirement

When properly installed and set, the Aprilaire Model 8140 will meet the mechanical ventilation requirements of:**

- + ASHRAE 62.2-2010
- + Energy Star Certified Homes, Version 3
- + EPA Indoor airPLUS, Version 1
- + 2012 & 2015 International Residential Code (IRC)
- + 2012 & 2015 International Energy Conservation Code (IECC)
- + California Energy Commission Title 24

*Pat. No. 9,874,366. Applies to all controls listed below.

**8140NC compliance is subject to the functionality of the external control. To assure compliance, use an 8910, 8910W, 8920W, 8620, 8620W thermostat or 8120X ventilation controller.

Fresh Air Ventilators

With Backdraft Damper, No Filter

Model 8142, 8142NC | Specification Sheet

SPECIFICATIONS

Overall dimensions	13 $\frac{1}{8}$ " W x 6 $\frac{7}{16}$ " H x 13 $\frac{1}{8}$ " L with control 13 $\frac{1}{8}$ " W x 6 $\frac{7}{16}$ " H x 11 $\frac{1}{16}$ " L without control
Inlet collar	6" Round
Outlet collar	6" Oval
Ventilation setting	Off, 6-60 min/hr Code/Comfort Operation
Ambient temperature	0°F-140°F
Outdoor temperature limits	Low: -10°F-40°F High: 85°F-105°F
Indoor RH limits	Low: 10-30% High: 45-70%
Voltage	115VAC, 1 phase, 60 Hz
Power	Includes 5' power cord
Ducting	6" dia. flexible insulated duct
Warranty	5 Years
ETL	Tested to UL Standard 705 Not for outdoor use

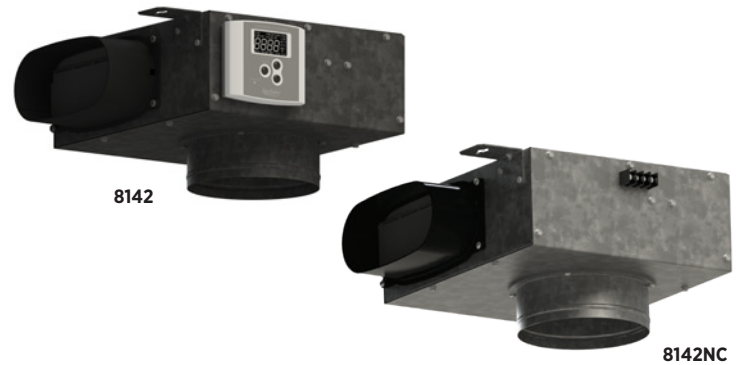

FEATURES

- + Control is integrated into the Model 8142 Ventilator. The Model 8142NC has no integrated control so the ventilator can be hardwired to the HVAC system and controlled from within the living space.
- + High and low outdoor temperature limit lock-outs while maintaining ASHRAE Standard 62.2-2010 (Model 8142 only)
- + High and low indoor relative humidity (RH) limits can be set on the controller (Model 8142 only)
- + Patented logic adjusts on-time and cycle time to meet ventilation requirements within set temp and RH ranges (Model 8142 only)*
- + Simple plug-in installation

BENEFITS

- + Delivers the precise amount of outside air needed in today's efficiently designed homes
- + Model 8142 optimizes energy savings by locking out ventilation during hottest/coldest times of the day
- + Improves indoor air quality
- + Robust design handles hot attics up to 140°F
- + Installation labor reduced, requires only a switched outlet and 24-volt wiring to HVAC system
- + Furnace or air handler does not require an ECM motor to meet efficacy requirement

When properly installed and set, the Aprilaire Model 8142 will meet the mechanical ventilation requirements of:**

- + ASHRAE 62.2-2010
- + Energy Star Certified Homes, Version 3
- + EPA Indoor airPLUS, Version 1
- + 2012 & 2015 International Residential Code (IRC)
- + 2012 & 2015 International Energy Conservation Code (IECC)
- + California Energy Commission Title 24

*Pat. No. 9,874,366. Applies to all controls listed below.

**8142NC compliance is subject to the functionality of the external control. To assure compliance, use an 8910, 8910W, 8920W, 8620 or 8620W thermostat or 8120X ventilation controller.

Figure 1 - Overall Dimensions (inches) Model 8142

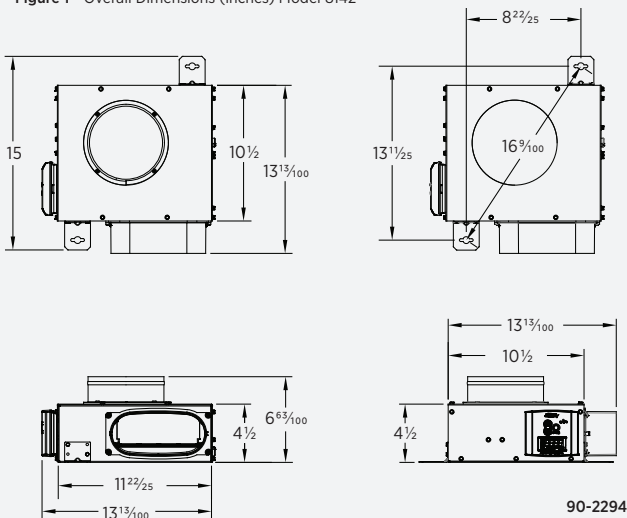
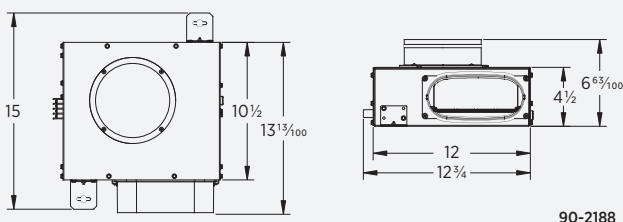

Figure 2 - Overall Dimensions (inches) Model 8142NC



Fresh air ventilator

For multi-family applications
Model 8144NC | Specification Sheet

SPECIFICATIONS

Overall dimensions	10¼" W x 19⅞" H x 10¼" D
Inlet collar	6" Round
Outlet collar	6" Oval
Ambient temperature	0°F–160°F
Voltage	115VAC, 1 phase, 60 Hz
Power	Hardwired
Ducting	6" diameter flexible insulated duct
Warranty	5 Years
ETL	Tested to UL Standard 705 Power ventilators not for outdoor use

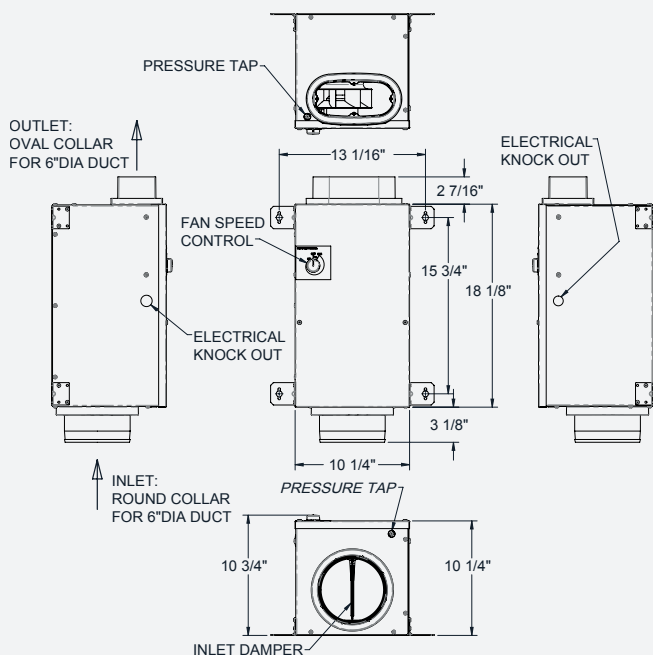

90-2287



FEATURES

- + Designed for use in continuous airflow applications up to 130 CFM
- + Unit is designed, when properly installed, to achieve ASHRAE Standard 62.2-2010
- + Complies with 2012 & 2015 IECC (2.8 cfm/watt)
- + Integrated powered damper
- + Removable, washable filter

BENEFITS

- + The precise amount of outside air is delivered to the dwelling
- + Improves indoor air quality
- + Robust design handles hot attics up to 160°F
- + Installation labor reduced versus installing components separately
- + Furnace or air handler does not require an ECM motor to meet efficacy requirement

When properly installed and set, the Aprilaire Model 8144NC Fresh Air Ventilator will meet the mechanical ventilation requirements of:

- + Energy Star Certified Homes, Version 3
- + EPA Indoor airPLUS, Version 1
- + 2012 & 2015 International Residential Code (IRC)
- + 2012 & 2015 International Energy Conservation Code (IECC)
- + 2012 & 2015 International Mechanical Code (IMC)
- + California Energy Commission Title 24

Ventilation Controller

Model 8120X | Specification Sheet

SPECIFICATIONS

Overall controller dimensions	4 $\frac{1}{100}$ " W x 3 $\frac{3}{8}$ " H x 1 $\frac{59}{100}$ " D
Duct opening dimensions (for humidity sensor)	$\frac{5}{8}$ " dia. in sheet metal, 5 $\frac{3}{4}$ " X 5 $\frac{1}{4}$ " for ductboard (ductboard bracket included)
Input power for the control (from the HVAC system transformer)	24VAC, 2VA
Damper output (Vent and GH)	10VA @ 30VAC max
Input voltage	18–30VAC
Controller power consumption	2.0VA
HVAC equipment terminals	R, C, W, Y, O, GS, GH
Equipment compatibility	Furnace and AC or Heat Pump
Outdoor temperature sensor inputs	Thermistor (provided)
Compliance	ASHRAE 62.2–2010
Installation temp limits	20°F–140°F



FEATURES

- + Easy-to-read LCD screen
- + Simple setup with three-button interface
- + Can be set for Code or Comfort (factory default setting)
- + 24-volt control
- + Measures outdoor temperature to stop ventilation at adjustable high and low outdoor temperature lockouts
- + Measures indoor humidity to stop ventilation at adjustable high and low humidity lockouts
- + Patented control programming maintains ASHRAE 62.2-2010 even during high and low temperature limit lockouts*
- + Installation flexibility—ability to override humidity and temperature control
- + Easy access to rater information (amount of CFM brought into the home, etc.)
- + Ductboard bracket included for accurate indoor humidity sensing

BENEFITS

- + Designed to meet ventilation requirements and conforms to latest building and energy codes
- + Easy to install and set up, saving you time and money
- + Increased customer comfort and energy savings over other economical ventilation options
- + Flexible setup allows you to meet every application

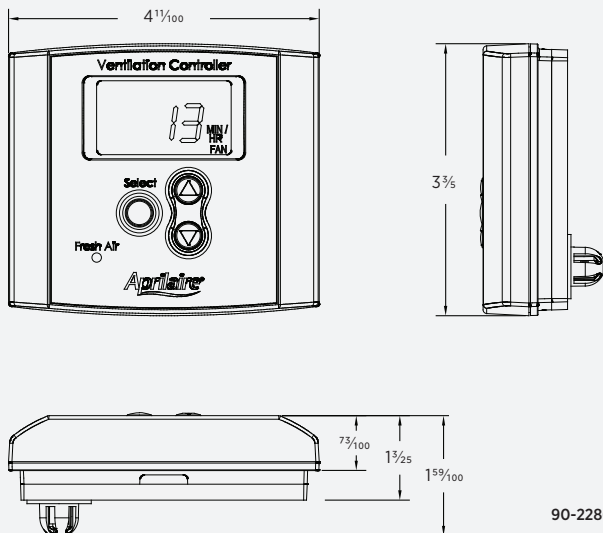

SPECIFICATIONS

Overall controller dimensions	4 ¹¹ / ₁₀₀ " W x 3 ³ / ₅ " H x 1 ⁵⁹ / ₁₀₀ " D
Duct opening dimensions (for humidity sensor)	5/8" dia. in sheet metal, 5 ³ / ₄ " X 5 ¹ / ₄ " for ductboard (ductboard bracket included)
Input power for the control (from the HVAC system transformer)	24VAC, 2VA
Damper (vent) and GH outputs	10VA @ 30VAC max
HVAC equipment terminals	R, C, W, Y, O, GS, GH
Equipment compatibility	Furnace and AC or Heat Pump
Outdoor temperature sensor inputs	Thermistor (provided)
Damper transformer (provided)	24VAC, 10VA
Compliance	ASHRAE 62.2-2010
Installation temp limits	20°F–140°F
Damper size	6" dia.
Overall damper dimensions (with actuator)	10 ³ / ₄ " H x 10 ¹ / ₅₀ " dia.
Max static pressure	1 in. w.c.
Max system velocity	1000 ft/min
Total power consumption	10VA (6 watts)

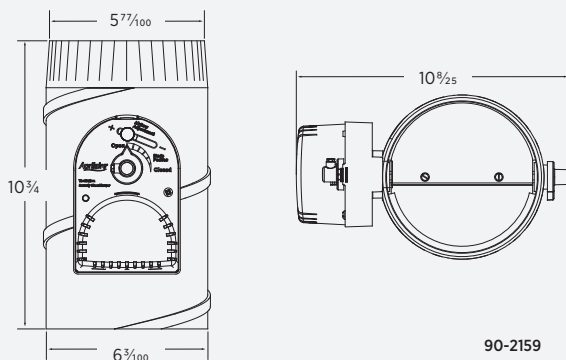
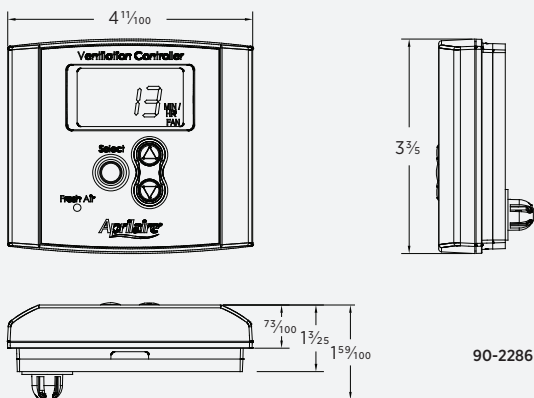

FEATURES

- + Includes 8120X ventilation controller, damper, 24 VAC transformer, outdoor temperature sensor and ductboard bracket for 8120X
- + Can be set for Code or Comfort (factory default setting)
- + Measures outdoor temperature to stop ventilation at adjustable high and low outdoor temperature lockouts
- + Measures indoor humidity to stop ventilation at adjustable high and low humidity lockouts
- + Patented control programming maintains ASHRAE 62.2-2010 even during high and low temperature limit lockouts*
- + Damper designed to be left in ductwork if actuator fails
- + Installation flexibility—ability to override humidity and temperature control
- + Easy access to rater information (amount of CFM brought into the home, etc.)

BENEFITS

- + Designed to meet ventilation requirements and conforms to latest building and energy codes.
- + Easy to install and set up, saving you time and money
- + Increased customer comfort and energy savings over other economical ventilation options
- + Flexible setup allows you to meet every application

*Pat. No. 9,874,366.

Kitchen Ventilation Kit Models 6508KV, 6510KV

Specification Sheet

TYPICAL AIRFLOW THROUGH MAKE-UP AIR DUCT

Available Negative Pressure		Make Up Airflow (CFM)	
in. w.c.	Pa	6508KV (8")	6510KV (10")
-0.02	-5	55	115
-0.04	-10	75	160
-0.06	-15	95	195
-0.08	-20	110	235
-0.10	-25	125	265
-0.20	-50	185	390
-0.30	-75	225	490
-0.40	-100	260	565
-0.50	-125	295	640
-0.60	-150	320	705

6508KV - 8" Round

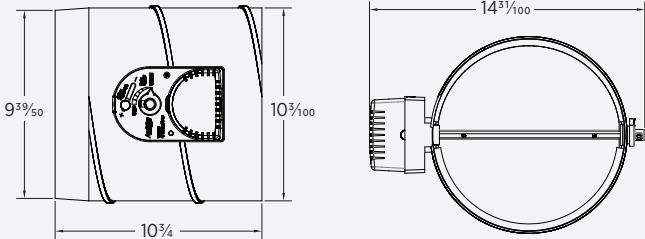

6510KV - 10" Round

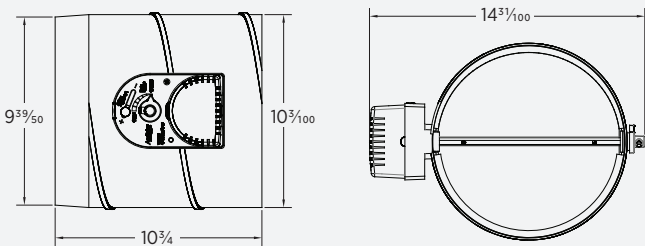

The Aprilaire 6508KV, 6510KV Kitchen Ventilation Kit is designed to locally provide make-up air to areas where high-CFM range hoods (typically near 400 CFM or above) are used to prevent home depressurization and its consequences. When the range hood's fan is operating, a normally closed damper—8" or 10" rounds—is powered open to allow make-up air to be drawn into the home. When the hood's fan is off, the damper is closed, preventing air from entering the home. The ventilation kit can also be tied into an HVAC system.

INCLUDES

- + Normally Closed/Power Open Damper
 - 6508KV - 8" round
 - 6510KV - 10" round
- + 24V AC, 10VA transformer
- + Model 50 Current Sensing Relay

FEATURES

- + 2-wire connection on damper.
- + Current sensing relay monitors when the range hood's fan is running without the need to disconnect its wiring.

SPECIFICATIONS

Overall dimensions	37 ³ / ₈ " W x 12 ³ / ₄ " D x 20 ² / ₄₀ " H
EnergyMax® transfer core	12 ¹ / ₈ " x 12 ¹ / ₈ " x 10 ³ / ₄ "
Air flow capacity	120 cfm @ 0.30 in. w.g. external ductwork resistance, i.e., 240 equivalent feet for each of the "fresh" and "stale" air streams.
Performance	Apparent Sensible Effectiveness (ASE) – 77% at rated ventilation capacity with 72°F indoor temperature and 32°F outdoor temperature.
Home size	Up to 3600 sq. ft. home at rated air flow.
Power requirements	120VAC, 1.4 ampere maximum. Unit equipped with a 3 ft. grounded power cord.
Interior insulation	Entire interior surface is sealed with 1" single face insulation.
Filters	(2) – 10 ¹ / ₁₆ " x 11 ⁵ / ₁₆ " x ³ / ₃₂ " EZ Kleen® air filters coated with Super Filter Coat adhesive for maximum performance.
Unit weight and packaging	Total shipping weight with mounting hardware – 76 lbs.

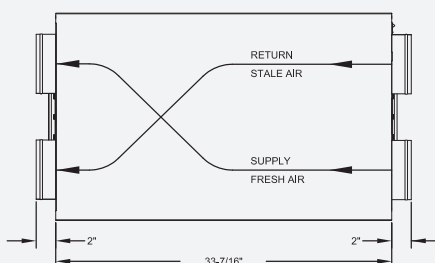
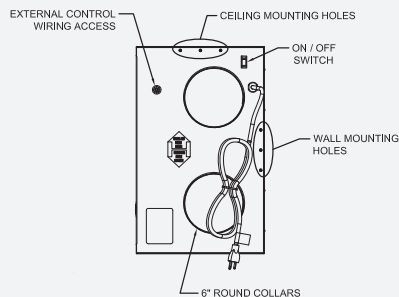
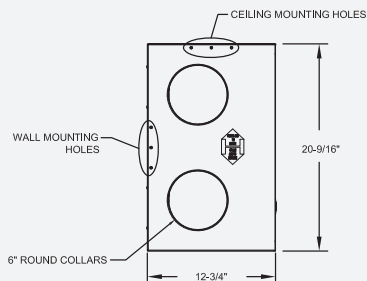

The 8100 Energy Recovery Ventilator expels stale indoor air and brings in fresh outside air with minimal impact on the heating and cooling efforts of the HVAC system.

FEATURES

- + Provides a constant and controlled supply of fresh air year-round
- + EnergyMax® transfer core technology uses the conditioned air being expelled to heat the incoming fresh air in the winter, reducing value loss from indoor air
- + EnergyMax® core also removes moisture and cools the incoming fresh air in the summer the same way it warms the air in the winter
- + Unit is designed, when properly installed, to achieve ASHRAE standard 62.2-2010
- + Can run continuously without a controller or on a schedule when wired to an 8120X ventilation controller
- + Minimal maintenance required
- + Quiet operation

BENEFITS

- + Brings fresh air into the home
- + Helps remove moisture from incoming air during warmer months
- + Reduces indoor air pollution by expelling pollutants that can build up indoors
- + Reduces energy costs by tempering incoming fresh air with outgoing air

When properly installed and set, the Aprilaire Model 8100 will meet the mechanical ventilation requirements of:

- + ASHRAE standard 62.2-2010
- + 2012 & 2015 International Residential Code (IRC)
- + 2012 & 2015 International Mechanical Code (IMC)

Aprilaire Ventilation Systems	Model No.	Unit Size	Dehumidification Capacity ppd = Pints Per Day	Shipping Weight lbs	Airflow 0.2 in. w.c. @ (CFM)	Product Description
FRESH AIR VENTILATORS WITH DEHUMIDIFICATION						
	8191	W: 12½" H: 14½" L: 25"	70 ppd	82.50	120	The ventilation control is integrated into the Aprilaire whole-home unit. The unit energizes its blower and opens a damper drawing fresh air into the home. If the incoming air is above a set relative humidity percentage, the incoming air is dehumidified.
	8192	W: 12½" H: 14½" L: 27½"	95 ppd	84.00	230	
FRESH AIR VENTILATORS						
	8140 8140NC	W: 14¾" H: 11⅝" L: 27⅝"	-	30.50 30.00	225	Aprilaire ventilation control energizes a blower in the ventilator and opens an integrated damper delivering fresh air into the return or the supply. NC models do not include an onboard controller so that ventilation can be controlled by a thermostat located within the living space.
	8142 8142NC	W: 13⅝" H: 6⅞" L: 11⅞"	-	12.36 9.80	210	
	8144NC	W: 10¼" H: 18⅝" D: 10¼"	-	20.50	130	The 8144NC is designed to provide continuous low-volume ventilation for smaller single- and multi-family homes. An 8120X ventilation controller may be added to set the unit for energy code ventilation or use high/low temperature and RH lock outs for comfort set up.
VENTILATION CONTROLLER						
	8120X	W: 4⅞" H: 3⅝" D: 1⅝"	-	.50	-	The 8120X engages a fan or damper on various Aprilaire ventilation solutions to allow the delivery of fresh air to a supply or return on the HVAC system. Control can be programmed to deliver the correct amount of fresh air required by code or within high/low outdoor temperature and indoor RH lockouts set by the installer or homeowner.
VENTILATION SYSTEM						
	8126X	W: 10⅝" H: 10¾" D: 6"	-	6.50	-	Aprilaire ventilation control energizes a powered damper mounted on the return side of the HVAC blower. When the HVAC blower energizes, negative pressure draws fresh air into the home.
KITCHEN VENTILATION KITS						
	6508KV	W: 8" H: 10¾" D: 12⅝"	-	6.00	185	The Aprilaire 6508KV, 6510KV Kitchen Ventilation Kit is designed to locally provide make-up air to areas where high-CFM range hoods (typically near 400 CFM or above) are used to prevent home depressurization and its consequences.
	6510KV	W: 10" H: 10¾" D: 14⅝"	-	6.70	390	
FRESH AIR EXCHANGER (ERV)						
	8100	W: 37⅝" H: 20⅜" D: 12¾"	-	87.00	130	Aprilaire ventilation control (not included) or thermostat energizes blowers in the ventilator drawing fresh air in and exhausting stale air out of the home. The air flow is balanced, eliminating pressure, and energy is transferred between incoming and outgoing air.