



SERVICE PARTS LIST

BULLETIN NO.
54-49-9005

SPECIFY CATALOG NO. AND SERIAL NO. WHEN ORDERING PARTS		REVISED BULLETIN	DATE
RATCHETING PIPE CUTTER			May 2017
CATALOG NO. 48-22-4210	1-5/8" OD Ratcheting Pipe Cutter	For the following materials: PVC, CPVC, PEX, ABS and Rubber Hose	
48-22-4215	2-3/8" OD Ratcheting Pipe Cutter		

Place blade return spring (2) into the channel of housing. Rotate the spring arm as shown until it catches raised ledge.

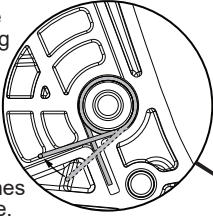

WARNING! Cutting blade (5) is very sharp. Care must be taken when installing or removing.

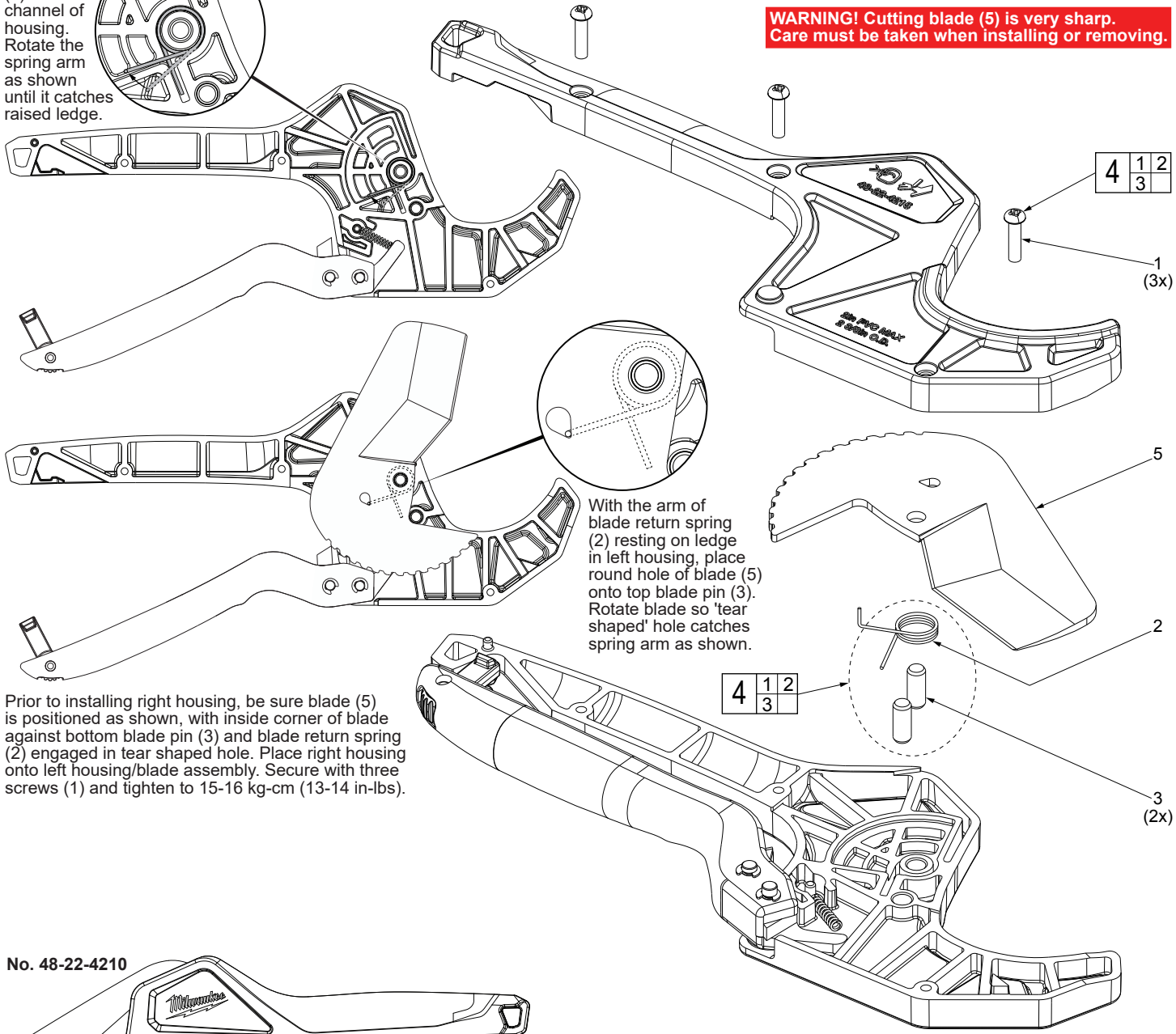

Prior to installing right housing, be sure blade (5) is positioned as shown, with inside corner of blade against bottom blade pin (3) and blade return spring (2) engaged in tear shaped hole. Place right housing onto left housing/blade assembly. Secure with three screws (1) and tighten to 15-16 kg-cm (13-14 in-lbs).

With the arm of blade return spring (2) resting on ledge in left housing, place round hole of blade (5) onto top blade pin (3). Rotate blade so 'tear shaped' hole catches spring arm as shown.

No. 48-22-4210

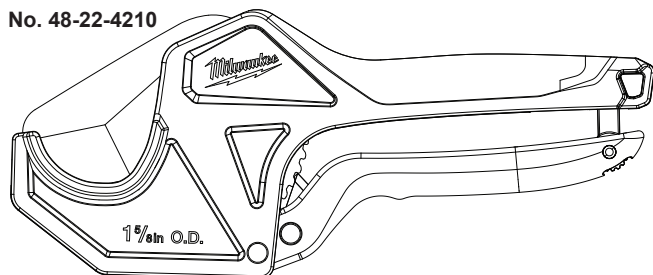

No. 48-22-4215

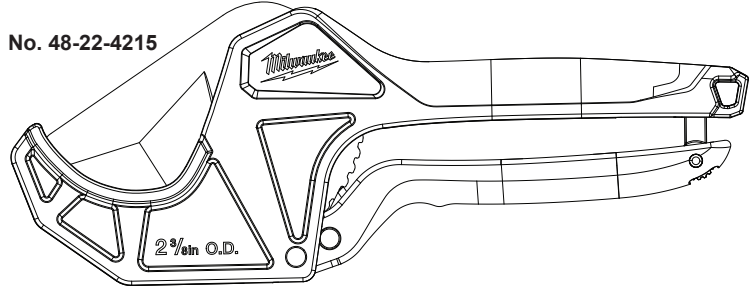

FIG.	PART NO.	DESCRIPTION OF PART	NO. REQ.
1	-----	M4 x 16mm Pan Hd. Phillips Screw	(3)
2	-----	Blade Return Spring	(1)
3	-----	Blade Pin	(2)
4	14-46-4210	Hardware Kit	(1)
5	48-22-4211	1-5/8" Ratcheting Pipe Cutter	
		Replacement Blade (Accessory)	(1)
	48-22-4216	2-3/8" Ratcheting Pipe Cutter	
		Replacement Blade (Accessory)	(1)