

PERFORMANCE DATA

To obtain Performance Data:

- Press and hold the ▼ (Down) button.
- While holding the ▼ (Down) button for 2 seconds, press and hold the "On/Off" button (hold both buttons simultaneously).

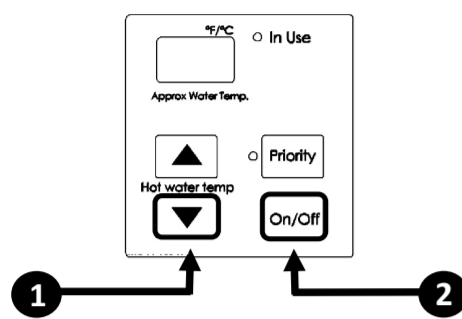

- Use the ▲ (Up) and ▼ (Down) buttons to scroll to the desired performance information described below.

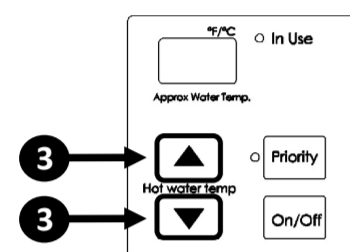

Performance Data Table

#	DATA	UNIT
01	Water Flow Rate	x0.1 gal/min
02	Outgoing Temperature	°F
03	Combustion Hours	x100 Hours
04	Combustion Cycles	See following information
05	Fan Frequency	Hz
06	Additional Controllers Connected	See following information
07	Water Flow Control Position	0=mid, 1=Open, 2=Closed
08	Inlet Temperature	°F
09	Fan Current	x10 mA
10	Total Bath Fill Amount	gallons
11	HEX Outlet Temperature	°F
12	By-Pass Flow Control Position	Degrees of opening
15	Freeze Protection Temperature (Indoor Unit Only)	°F
17	Freeze Protection Temperature (Outdoor Unit Only)	°F
19	Pump Hours	x100 Hours
20	Pump Cycles	See following information
21	Exhaust Temperature	°F

DISPLAY	CYCLE COUNT
000 to 999	x100 (0 to 99,900)
10- to 99-	x10,000 (100,000 to 990,000)
1-- to 6--	x1,000,000 (1,000,000 to 6,000,000)

CONTROLLER MODEL	CONNECTED	NOT CONNECTED
MC	..1	..0
BC	..1	..0
BSC & BSC2	1-- , 2-- (QTY2)	0--

Default display is 100.

depends on connection status of another controller.

PARAMETER SETTINGS

To adjust the parameters:

- Press the "A" button for 1 second.

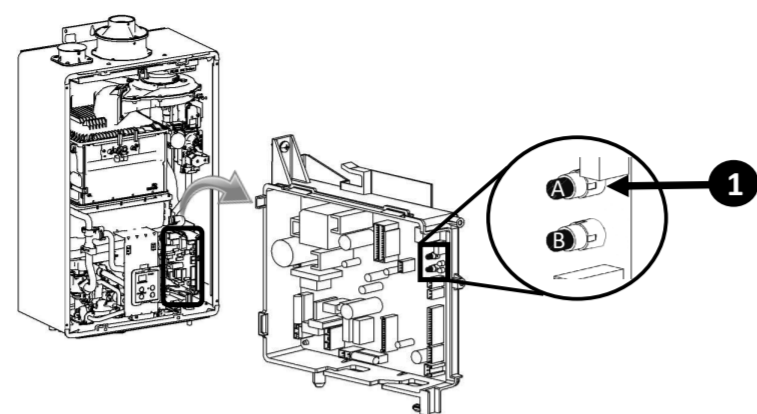

- Use the ▲ (Up) and ▼ (Down) button on the controller to select a setting number (See Parameter Settings Table).

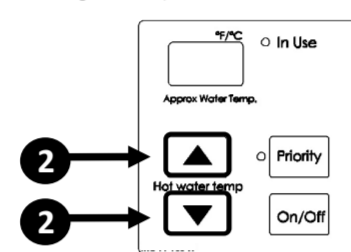

- Once the desired setting number is selected, use the "On/Off" button on the controller to change the selection for the setting number. Example: Display will change from 01A to 01b for Maximum Temperature setting (as shown below).

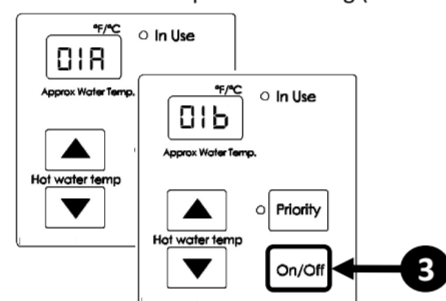

- To exit the parameters, press the "A" button on the PC board for 1 second.

Parameter Settings Table

Default is A for all settings below except 10, 12, 13, and 14 which are factory set.

SETTING #	SETTING DESCRIPTION	SELECTION					
		A	b	C	d	E	F
01	Maximum Set Temperature	Residential: 120°F Commercial: 140°F	Residential: 140°F Commercial: 185°F				
02	High Altitude (Installation Location)	0 - 2,000 ft (0 - 610 m)	2,001 - 5,400 ft (610 - 1,646 m)	5,401 - 7,700 ft (1,646 - 2,347 m)	7,701 - 10,200 ft (2,347 - 3,109 m)		
03	Service Soon ¹	Disabled	0.5 Year	1 Year	2 Years		
04	Recirculation Settings	No Recirculation	Recirculation (Dedicated)				
05	Recirculation Mode ²	Comfort	Economy				
06	Control Switch	BMS ³	Air Handler (AH)				
07	Units in Standby (EZ Connect)	2	1				
08	Cascade	Secondary	Primary				
09	Units in Standby (Cascade)	1	2	3	4	5	6
10	Gas Type (Factory Set)	NG	LPG				
11	Maximum Flow Rate ⁴	Standard	High				
12	Water Heater Model	Without Pump	With Pump				
13	(Factory set values and not adjustable)	199 (3237)	180 (2934)	160 (2530)	130 (2024)		
14		Internal	External				

¹ See section "Service Soon, 55" in the Installation and Operation Manual for more information.

² Setting 05 is available only if setting 04b is selected. **Comfort mode** cycles the pump more frequently, ensuring the loop temperature remains higher (but also uses more energy). **Economy mode** cycles the pump less often, using less energy to maintain the circulation loop temperature.

³ BMS = Building Management System

⁴ Setting 09 is available only if setting 08b is selected.

⁵ Selecting "High" will increase the water flow rate to the maximum capacity.

ELECTRICAL DIAGNOSTICS

NOTE: Wiring diagram is available in manual and on the inside front cover.

Important Safety Notes

There are a number of (live) tests required when performing electrical diagnostics on this product. Proceed with caution at all times to avoid contact with energized components inside the water heater. Only trained and qualified service technicians should attempt to repair this product. Before checking for resistance readings, disconnect the power source to the unit and isolate the item from the circuit (unplug it).

Freeze Protection

This unit has freeze protection heaters mounted at different points to protect the water heater from freezing. All of them should display a positive resistance reading.

Flame Rod

Place one lead of your meter to the flame rod and the other to ground. With the unit running you should read between 5 - 150 VAC. Set your meter to the micro (μ) amp scale and arrange meter leads in line with the flame rod. You should read 1 μ amp or greater for proper flame circuit. In the event of low flame circuit, remove the flame rod and check for carbon or damage.

Amp Fuses

This unit has two glass fuses located on the PC Board, one inline (10) amp and one (4) amp glass fuse. Remove the fuses and check continuity through it. If you have continuity through each fuse then it is functioning. Otherwise the fuse is blown and must be replaced.

Thermistors

Check all thermistors by inserting meter leads into each end of the thermistor plug. Set your meter to the 20 K scale and read resistance. Applying heat to the thermistor bulb should decrease the resistance. Applying ice to the thermistor bulb should increase the resistance.

Below are examples of typical temperatures and resistance readings.

Temperature	Resistance Readings
59°F	11.4 - 14KΩ
86°F	6.4 - 7.8KΩ
113°F	3.6 - 4.5KΩ
140°F	2.2 - 2.7KΩ
221°F	0.6 - 0.8KΩ

Electrical Circuit Table

COMPONENT	WIRE COLOR	VOLTAGE	RESISTANCE	PCB		
				CONNECTOR	CONNECTOR	PIN
Spark Electrode	Red-Black	11~13VDC*	34 K ~ 40 K ohms	D2	D	12-21
	Red-Black	7~48VDC*	N/A	D3	D	4-6
Combustion Fan	White-Black	10~12VDC*	N/A	D3	D	10-6
	Yellow-Black	11~13VDC*	N/A	D3	D	8-6
	Red-Pink	N/A	44~52 ohms	D4	D	18-20
Water Flow Control Device	White-Blue	N/A	44~52 ohms	D4	D	16-14
	Grey-Orange	12~14VDC	N/A	D4	D	30-12
	Blue-White	N/A	35~41 ohms	D5	D	5-7
Venturi Control Device	Yellow-Red	N/A	35~41 ohms	D5	D	11-9
	Black-Red	12~14 VDC	N/A	D5	D	30-12
	Black-Brown	less than 1VDC*		D5	D	30-25
	Black-Grey	less than 1VDC*		D5	D	30-23
By-Pass Flow Control Device	Red-Pink	N/A	44~52 ohms	D6	D	15-13
	White-Blue	N/A	44~52 ohms	D6	D	17-19
Gas Solenoid Valve	Yellow-Black	11~13VDC*	18~22 ohms	D7	D	29-27
	White-White			H1	H	3-2
Outgoing Thermistor	Blue-Blue			H1	H	8-11
Inlet Thermistor	White-White			H2	H	4-2
Exhaust Thermistor	White-White			H3	H	2-5
Heat Exchanger Thermistor	White-White			H4	H	2-6
Freeze Protection Thermistor	Yellow-Black			H5	H	2-7
Overheat Switch	Black-Black	11~13 VDC	less than 1 ohm	H6	H	28-14
Water Flow Sensor	Black-Red	11~13 VDC	N/A	H7	H	30-12
	Yellow-Black	4~7 VDC*	N/A	H7	H	12-30
Recirculation Pump (Optional)	White-Black	108~132 VAC	17~21 ohms	B1	B	1-2
Additional Controller(s)	White-White	10~13 VDC	N/A	K	-	-

(* Value to be measured while unit is in operation)

DIAGNOSTIC CODES

To display diagnostic codes:

- Turn off the water heater by pressing the "On/Off" button.
- Press and hold the "On/Off" for 2 seconds and then the ▲ (Up) button simultaneously.
- The last 9 maintenance codes display and flash one after the other.
- To exit diagnostic codes and return the water heater to normal operation, press and hold the "On/Off" button for 2 seconds and then the ▲ (Up) button simultaneously.
- Turn on the water heater by pressing the "On/Off" button.

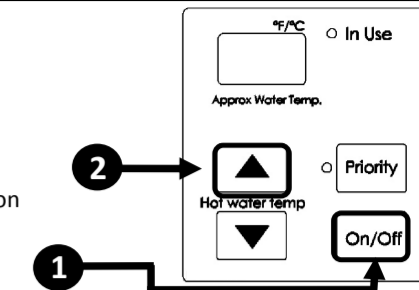

03	Power interruption during bath fill (Water will not flow when power returns) • Turn off all hot water taps. Press ON/OFF twice.	51	Inlet Thermistor • Check sensor wiring for damage. • Measure resistance of sensor. (See Electrical Diagnostics) • Clean sensor of scale build-up. • Replace sensor.
05	By-Pass Flow Control • Measure resistance values of the by-pass flow control (See Electrical Diagnostics). • Replace By-Pass flow control device.	52	Gas Valve • Check flame rod and wire for damage. • Check gas solenoid valve for open or short circuit. (See Electrical Diagnostics) • Replace gas valve assembly. • Please call Rinnai technical department.
10	Air Supply or Exhaust Blockage/Condensate Trap is Full • Ensure condensate line is not blocked. • Ensure internal air filter is clean with no obstructions. (Indoor Only) • Ensure High Altitude setting. (See Parameter Settings) • Ensure Combustion air and Exhaust vents are not blocked and approved venting materials are being used. (Indoor Only) • Ensure vent length is within limits. (Indoor Only) • Check fan for debris and ensure wheel turns freely. • Verify check valve is not stuck between fan casing and burner body.	54	High Exhaust Gas Temperature • Ensure condensate line is not blocked. • Ensure Heat Exchanger fins are clean and not blocked. • Confirm inlet water temperature is not too high. • Clear diagnostic code by resetting the main power supply to the water heater.
11	No Ignition (Heater Not Turning On) • Check that the gas is turned on at the water heater, meter, or cylinder. • If the system is propane, make sure that gas is in the tank. • Ensure gas type and inlet gas pressure are correct. • Bleed all air from gas lines. • Check the ground wire for the PC Board. • Ensure flame rod wire is connected. • Ensure igniter is operational. (See Electrical Diagnostics) • Check gas solenoid valves for open or short circuits. (See Electrical Diagnostics) • Verify gas orifice is correct. • Ensure condensate line is not blocked.	61	Combustion Fan • Check the motor wire harness for loose or damaged connections. • Measure resistance of motor wire harness. (See Electrical Diagnostics) • Ensure the combustion fan spins freely.
12	No Flame • Check that the gas is turned on at the water heater, gas meter, or cylinder. • If the system is propane, make sure that gas is in the tank. • Ensure flame rod wire is connected. • Ensure gas type and inlet gas pressure is correct. • Bleed all air from gas lines.	63	Recirculation Low Flow • Ensure bypass plug is removed and bypass filter is installed. (COV Mode) • Ensure both the inlet water filter and bypass filter are clean and free of debris. • Ensure Parameter setting are correctly set for recirculation mode. • Ensure Pump supply voltage. • Ensure air is removed from the recirculation line.
14	Heat Exchanger Overheat • Measure resistance of Overheat Switch. (See Electrical Diagnostics) • Check heat exchanger surface for hot spots which indicate blockage due to scale build-up. • Refer to instructions in manual for flushing heat exchanger. Hard water must be treated to prevent scale build-up or damage to the heat exchanger. • Ensure it is not forced Hi setting.	65	Water Flow Control • Measure resistance values of the water flow control (See Electrical Diagnostics) • The water flow control valve has failed to close during the bath fill function. Immediately turn off the water and discontinue the bath fill function. Contact a licensed professional to service the appliance.
15	Venturi Control • Ensure the Venturi motor is operating correctly. (See Electrical Diagnostics) • Replace gas valve assembly. • Clear diagnostic code by resetting the main power supply to the water heater.	70	PC Board • Replace PC Board
16	High Outgoing Temperature (safety shutdown because water heater is too hot) • Confirm fan motor is functioning correctly. • Replace the gas valve assembly.	71	Solenoid Valve Circuit • Ensure dip switch on PC board is in the OFF position. • Ensure gas control wire is not loose or damaged. • Ensure heater circuit is not grounded. • Replace PC Board.
17	Venturi Blockage • Ensure Venturi isn't blocked. • Please call Rinnai technical department.	72	Flame Rod • Check flame rod and wire for damage. • Verify HEX is not leaking.
19	Electrical Grounding • Check all components for electrical short.	55	(SS) Service Soon (Flush Heat Exchanger) • 55 is a time-based service indicator set during installation. See section "3.12 Parameter Settings" for additional details on setting and changing the 55 indicator. • 55 indicates that it is time for service. The heat exchanger should be flushed to prevent damage (refer to section "5.3 Flushing the Heat Exchanger" for more information). Hard water must be treated to prevent scale build-up or damage to the heat exchanger. • To reset the 55 code, push the On/Off button on the temperature controller 5 times in 5 seconds.
21	Data Transfer Error • If the PCB has been replaced, ensure the data transfer process has been completed.	NO CODE - Nothing happens when water flow is activated • Verify you have at least the minimum flow rate required to fire unit. • Measure the resistance of the water flow control sensor. (See Electrical Diagnostics) • Clean inlet water supply filter. • On new installations ensure hot and cold water lines are not reversed.	
25	Condensate Pump (Accessory) • Confirm wire connections and harness are good. • Ensure condensate reservoir is empty and condensate pump is operating.	5E	Cascade Diagnostic Display (Commercial units only) • With cascade connections, display will flash between "5E" and the selected set temperature when an error code is displayed on any secondary unit.
32	Outgoing Thermistor	FF	Maintenance Indicator • Placeholder in Diagnostic code history indicating that a service provider performed maintenance or service. • Enter this code after performing service by pressing ▲ (Up), ▼ (Down) and On/Off simultaneously. • FF is visible on the monitor.
33	Heat Exchanger Thermistor • Check sensor wiring for damage. • Measure resistance of sensor. (See Electrical Diagnostics) • Replace sensor.		
38	Exhaust Thermistor • Check sensor wiring for damage. • Measure resistance of sensor. (See Electrical Diagnostics) • Replace sensor.		
41	Freeze Protection Thermistor • Check sensor wiring for damage. • Measure resistance of sensor. (See Electrical Diagnostics) • Replace sensor.		

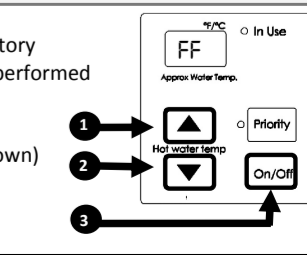

Gas Conversion Kits	
RU199i, CU199i	103000076
RU199e, CU199e	103000077
RU180i	103000078
RU180e	103000079
RU160i, CU160i	103000080
RU160e, CU160e	103000081
RU130i	103000082
RU130e	103000083

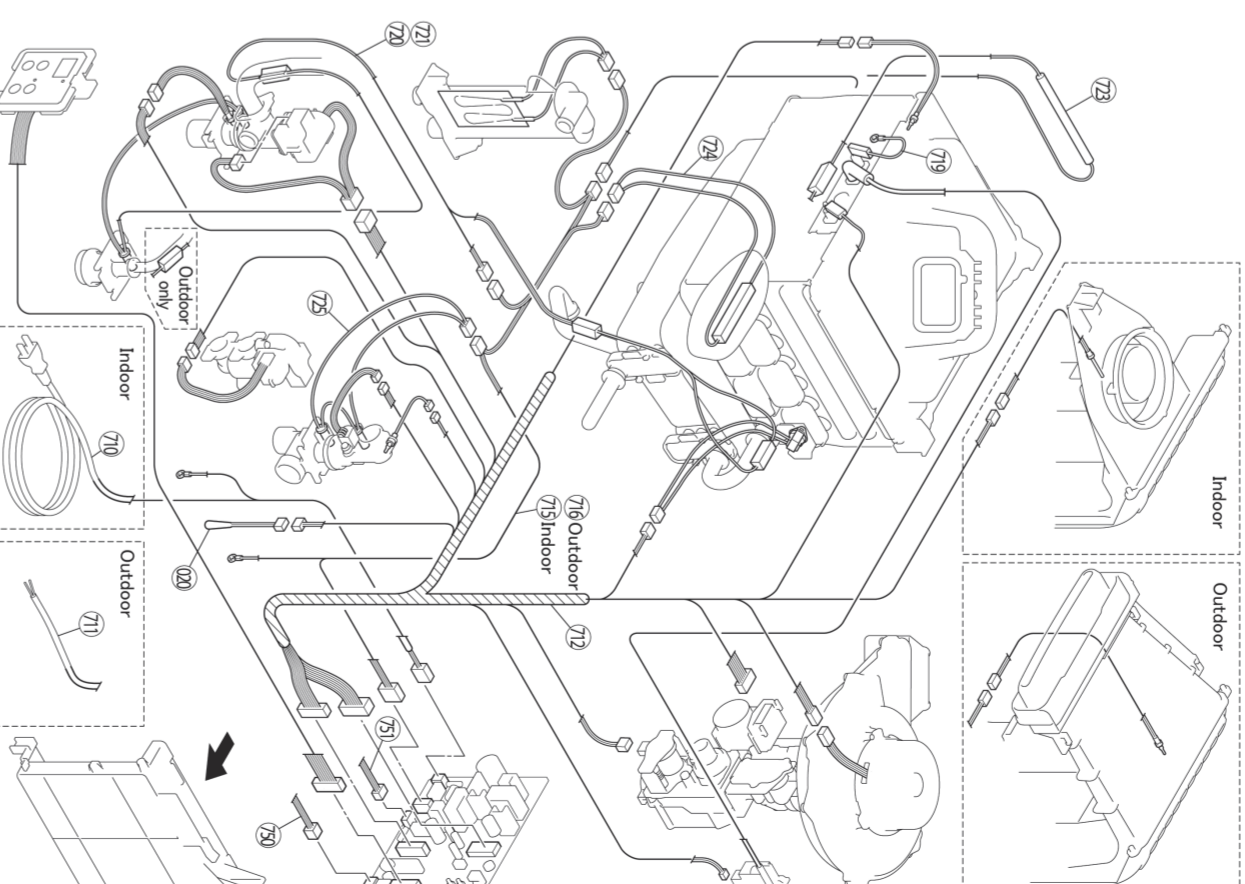
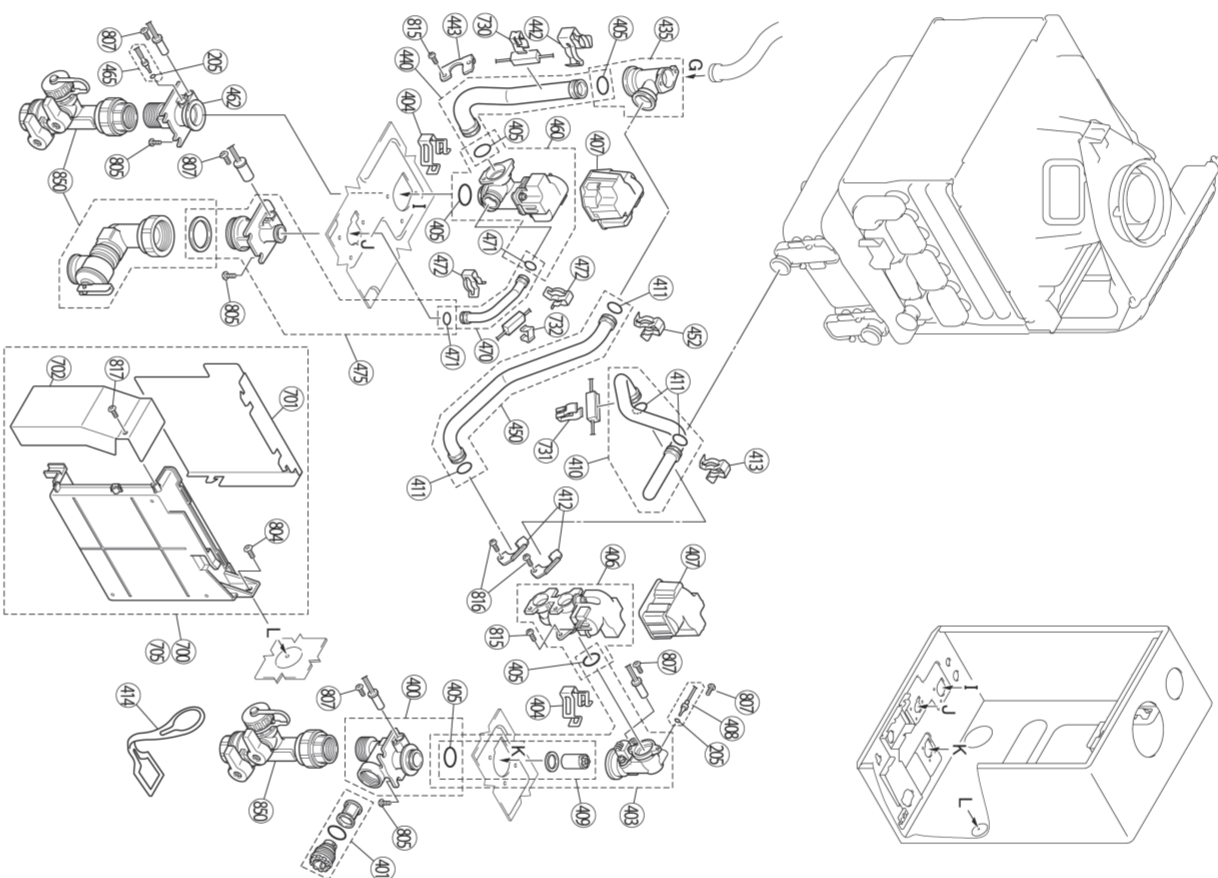
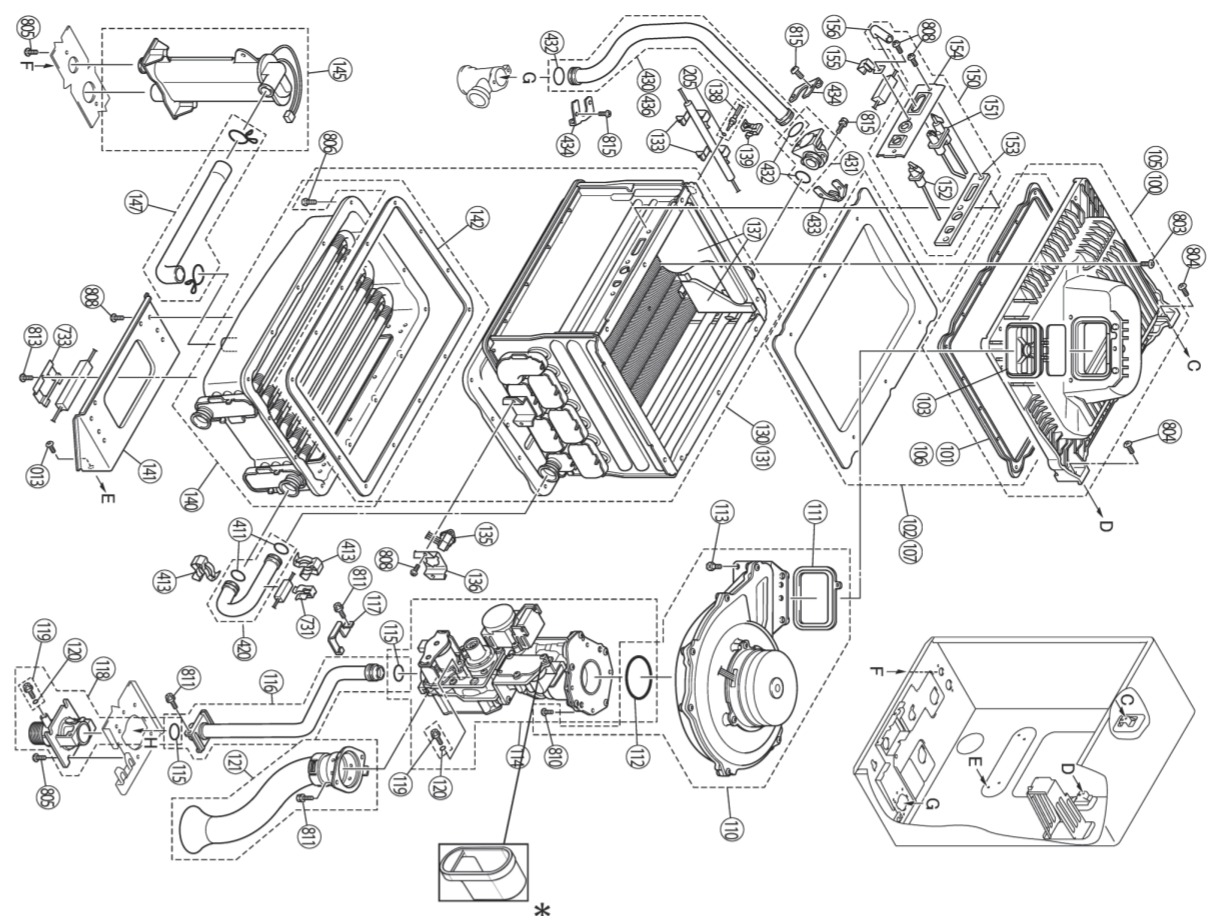
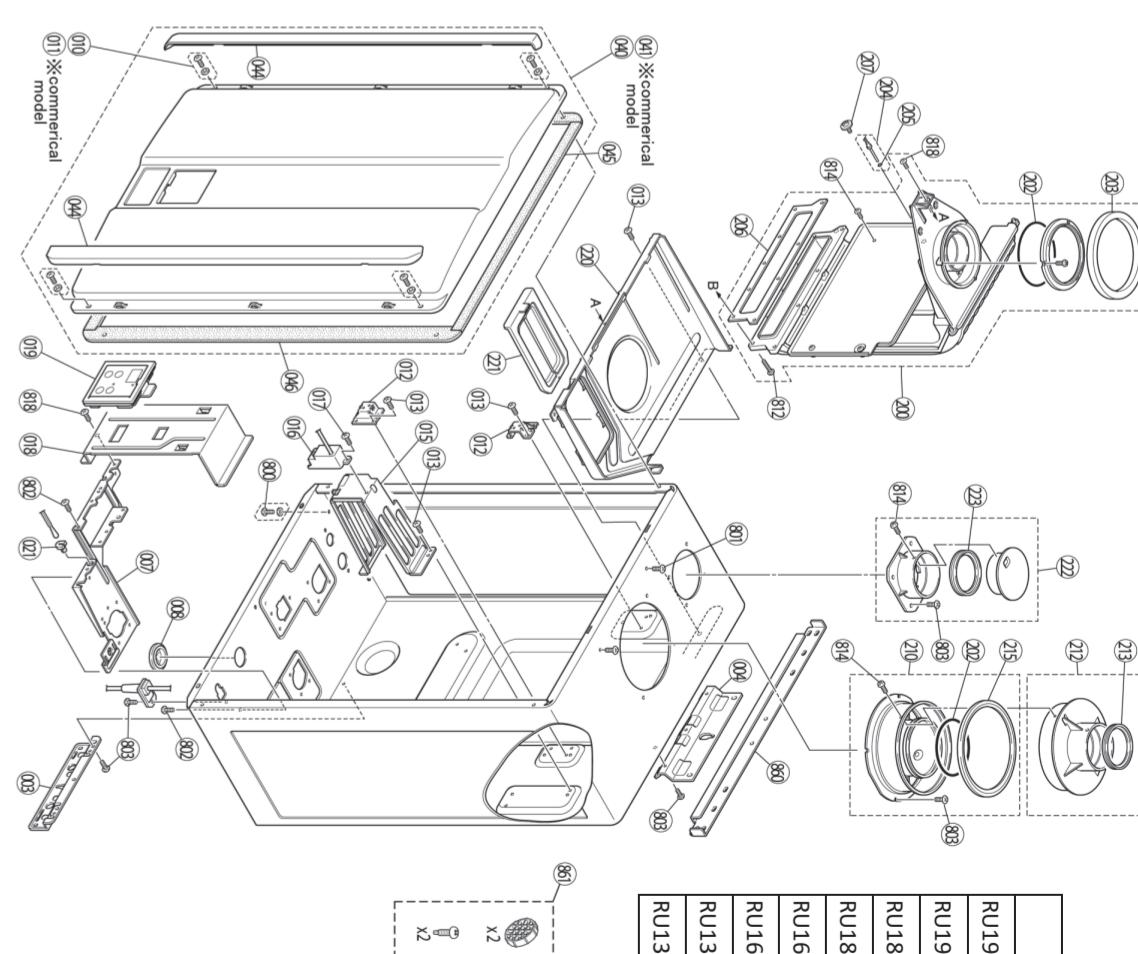
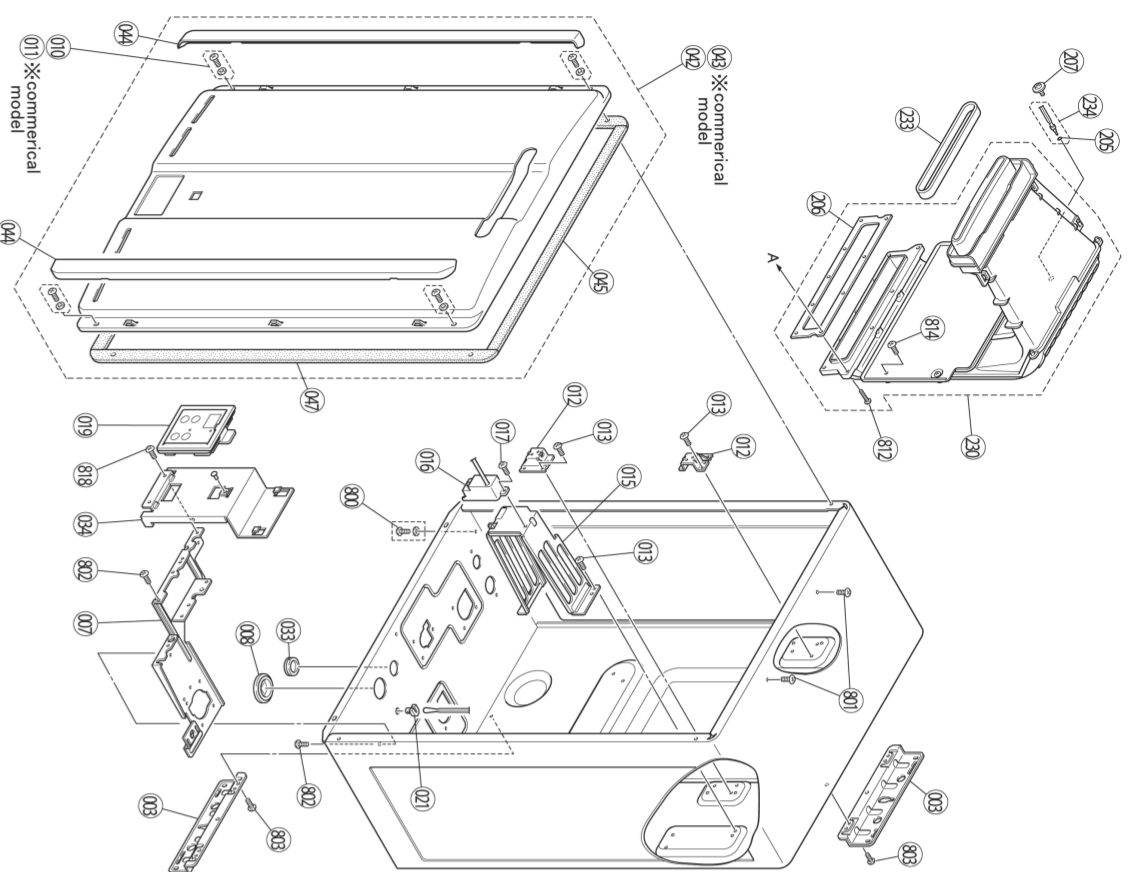

ITEM	DESCRIPTION	PART NUMBER	RU199i RU180i	RU199e RU180e	RU160i RU130i	RU160e RU130e	CU199i	CU199e	CU160i	CU160e
003	Lower Wall Mount Bracket	109000281	1	2	1	2	1	2	1	2
004	Upper Wall Mount Bracket	109000594	1	1	1	1	1	1	1	1
007	Connection Reinforcement Plate	109000595	1	1	1	1	1	1	1	1
008	Rubber Bushing	109000634	1	1	1	1	1	1	1	1
010	Residential Screw & Washer-Gray	106000645	4	4	4	4	4	4	4	4
011	Commercial Screw & Washer-Black	109000596	2	2	2	2	2	2	2	2
012	Combustion Chamber Support Plate	109000597	2	2	2	2	2	2	2	2
013	Truss Screw	109000598	14	12	14	12	14	12	14	12
015	Lighter Bracket	109000599	1	1	1	1	1	1	1	1
016	Igniter Assembly	105000230	1	1	1	1	1	1	1	1
017	Grounding Screw	CP-80452	1	1	1	1	1	1	1	1
018	Controller Bracket FF	109000600	1	1	1	1	1	1	1	1
019	Controller	105000260	1	1	1	1	1	1	1	1
020	Thermistor/ Sensor	105000261	1	1	1	1	1	1	1	1
021	Thermistor Grommet	109000490	1	1	1	1	1	1	1	1
023	Rubber Bushing	CF79-41020-A	1	1	1	1	1	1	1	1
034	Controller Bracket W	109000603	1	1	1	1	1	1	1	1
040	Residential Front Cover Panel FF	109000604	1	1	1	1	1	1	1	1
041	Commercial Front Cover Panel FF	109000605	1	1	1	1	1	1	1	1
042	Residential Front Cover Panel W	109000606	1	1	1	1	1	1	1	1
043	Commercial Front Cover Panel W	109000607	1	1	1	1	1	1	1	1
044	Screw Cover	109000120	2	2	2	2	2	2	2	2
045	Front Panel Packing - Top	109000120	2	2	2	2	2	2	2	2
046	Front Panel Packing - Side FF	109000608	2	2	2	2	2	2	2	2
047	Front Panel Packing - Side W	109000121	2	2	2	2	2	2	2	2
100	Burner Case - Large	109000113	1	1	1	1	1	1	1	1
101	Burner Gasket - Large	109000609	1	1	1	1	1	1	1	1
102	Burner Plate Assembly - Large	106000114	1	1	1	1	1	1	1	1
103	Combustion Check Valve Assembly	106000262	1	1	1	1	1	1	1	1
105	Burner Case - Small	106000115	1	1	1	1	1	1	1	1
106	Burner Gasket - Small	109000610	1	1	1	1	1	1	1	1
107	Burner Plate Assembly - Small	106000116	1	1	1	1	1	1	1	1
110	Combustion Fan Assembly	108000081	1	1	1	1	1	1	1	1
111	Fan Mounting Packing	109000611	1	1	1	1	1	1	1	1
112	O-Ring	109000612	3	3	3	3	3	3	3	3
113	Hexagon Head Screw	Z0AA0514UK	3	3	3	3	3	3	3	3
114	Gas Valve Assembly with Orifice	106000117	1	1	1	1	1	1	1	1
115	O-Ring	109000252	2	2	2	2	2	2	2	2
116	Gas Connection Pipe	106000118	1	1	1	1	1	1	1	1
117	Gas Tube Bracket	109000635	1	1	1	1	1	1	1	1
118	Inlet Gas Supply Connection	106000119	1	1	1	1	1	1	1	1
119	Inlet Gas Test Port Screw	M10B-13-4	2	2	2	2	2	2	2	2
120	O-Ring	106000120	1	1	1	1	1	1	1	1
121	Noise Filter	107000263	1	1	1	1	1	1	1	1
130	Heat Exchanger Assembly - Large	107000264	1	1	1	1	1	1	1	1
131	Heat Exchanger Assembly - Small	109000613	2	2	2	2	2	2	2	2
133	Heater Bracket	105000231	1	1	1	1	1	1	1	1
135	Over Heat Sensor (OHS)	109000614	1	1	1	1	1	1	1	1
136	OHS Bracket	107000265	1	1	1	1	1	1	1	1
137	Heat Exchanger Insulator	105000266	1	1	1	1	1	1	1	1
138	Thermistor	105000090	1	1	1	1	1	1	1	1
139	Clip	107000266	1	1	1	1	1	1	1	1
140	Secondary Heat Exchanger	109000615	1	1	1	1	1	1	1	1
141	Secondary Heat Exchanger Bracket	109000615	1	1	1	1	1	1	1	1

ITEM	DESCRIPTION	PART NUMBER	RU199i RU180i	RU199e RU180e	RU160i RU130i	RU160e RU130e	CU199i	CU199e	CU160i	CU160e
142	Secondary Heat Exchanger Gasket	109000616	1	1	1	1	1	1	1	1
145	Condensate Trap	107000267	1	1	1	1	1	1	1	1
147	Condensate Drain Tube	107000268	1	1	1	1	1	1	1	1
150	Electrode/Flame Rod Assembly	105000232	1	1	1	1	1	1	1	1
151	Electrode	105000233	1	1	1	1	1	1	1	1
152	Flame Rod	105000234	1	1	1	1	1	1	1	1
153	Electrode Packing	109000618	1	1	1	1	1	1	1	1
154	Electrode Plate	109000619	1	1	1	1	1	1	1	1
155	Electrode Heater Bracket	109000620	1	1	1	1	1	1	1	1
156	Electrode Sleeve	108000082	1	1	1	1	1	1	1	1
200	Exhaust Duct Assembly FF	108000082	1	1	1	1	1	1	1	1
202	O-Ring	108000018	2	2	2	2	2	2	2	2
203	Exhaust Duct Packing	109000621	1	1	1	1	1	1	1	1
204	Thermistor	105000235	1	1	1	1	1	1	1	1
205	O-Ring	107000323	4	4	4	4	4	4	4	4
206	Exhaust Packing	109000646	1	1	1	1	1	1	1	1
207	Thermistor Screw	109000622	1	1	1	1	1	1	1	1
210	File Connection Assembly	108000083	1	1	1	1	1	1	1	1
212	Exhaust Pipe Connection Port-2"	108000084	1	1	1	1	1	1	1	1
213	Exhaust Gasket- 2 inch	109000623	1	1	1	1	1	1	1	1
215	Air Supply Pipe Seal Ring	108000017	1	1	1	1	1	1	1	1
220	Air Supply Box	108000085	1	1	1	1	1	1	1	1
221	Air Supply Filter	108000086	1	1	1	1	1	1	1	1
222	Air Supply Connection	108000087	1	1	1	1	1	1	1	1
223	Air Supply Gasket - 2 inch	109000624	1	1	1	1	1	1	1	1
230	Exhaust Duct Assembly W	108000088	1	1	1	1	1	1	1	1
233	Front Exhaust Seal W	108000094	1	1	1	1	1	1	1	1
234	Thermistor	105000633	1	1	1	1	1	1	1	1
400	3/4 Water Supply Connection	107000316	1	1	1	1	1	1	1	1
401	Water Supply Filter Plug Assembly	107000317	1	1	1	1	1	1	1	1
403	Water Flow Sensor Assembly	109000636	2	2	2	2	2	2	2	2
404	Clip	107000324	6	6	6	6	6	6	6	6
405	O-Ring	107000270	1	1	1	1	1	1	1	1
406	Bypass Servo Assembly	107000093	1	1	1	1	1	1	1	1
407	Cover	107000093	1	1	1	1	1	1	1	1
408	Inlet Water Thermistor	107000318	1	1	1	1	1	1	1	1
409	Flow Turbine Assembly	107000319	1	1	1	1	1	1	1	1
410	Water Supply Connection Pipe	107000271	1	1	1	1	1	1	1	1
411	O-Ring	M10B-2-14	6	6	6	6	6	6	6	6
412	Retention Clip	AH69-310	2	2	2	2	2	2	2	2
413	Clip	109000244	3	3	3	3	3	3	3	3
414	Plug Band	109000272	1	1	1	1	1	1	1	1
420	Secondary Connecting Pipe	107000273	1	1	1	1	1	1	1	1
430	Connection Pipe Assembly - Large	107000274	1	1	1	1	1	1	1	1
431	Heat Exchanger Pipe Connection	107000275	4	4	4	4	4	4	4	4
432	O-Ring	109000637	1	1	1	1	1	1	1	1
433	Pipe Bracket	109000637	2	2	2	2	2	2	2	2
434	Retention Clip	109000496	1	1	1	1	1	1	1	1
435	Hot Water Connection fitting	107000275	1	1	1	1	1	1	1	1
436	Connection Pipe Assembly-Small	107000276	1	1	1	1	1	1	1	1
440	Hot Water Supply Connection Pipe	107000277	1	1	1	1	1	1	1	1
442	Clip	109000638	1	1	1	1	1	1	1	1
443	Retention Clip	U211-322X01	1	1	1	1	1	1	1	1
450	Bypass Pipe Assembly	107000278	1	1	1	1	1	1	1	1

Rinnai America Corporation continually updates materials, and as such, content is subject to change without notice. For further information, contact Rinnai at 1-800-621-9419 or visit www.rinnai.us