

Digital Adjustable Torque Wrench

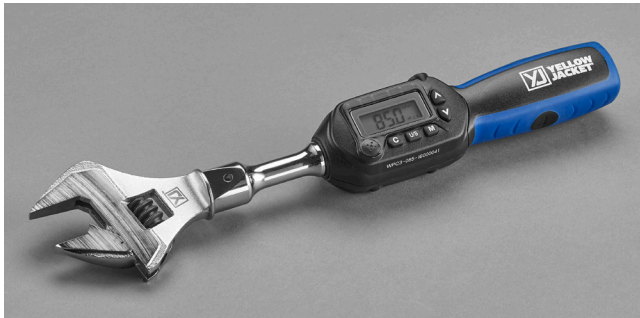

FEATURES & BENEFITS

- Adjustable spanner head
- Digital torque value readout
- +/- 2% accuracy
- CW and CCW operation
- Peak hold and track mode selectable
- Buzzer and LED indicator for the nine pre-set target torques
- Four user selectable units of measure (ft. lb., in. lb., N-m, kg-cm)
- 50 data memory for recall and joint torque auditing
- Auto sleep (after about five minutes idle)
- Water contact indicator



UPC#	Description
60648	Adjustable Digital Torque Wrench
60632	3/8" Drive Ratchet Head
60647	Adjustable Wrench Head 5-30mm

The YELLOW JACKET® Adjustable Digital Torque Wrench captures and displays torque measurement in real time mode, providing users with unprecedented levels of control and accuracy.

The YELLOW JACKET® Adjustable Digital Torque Wrench captures and displays torque measurement in real time mode, providing users with unprecedented levels of control and accuracy.

For convenience, the torque wrench has nine common preset torque values, which display on the digital screen as the flare nut is tightened. For added assurance, indicator lights increase as the torque value is approached.

The adjustable wrench head means you can leave your other wrenches at home, and the protective carrying case keeps it safe as you carry it from job site to job site.

SPECIFICATIONS

Square Drive:	3/8 in.
Length:	10.6 in. (270 mm)
Maximum Torque:	62.7 ft. lb. (85 N-m) 752 in. lb. (867 kg-cm)
Torque Measuring Range:	3.1 - 62.7 ft. lb. (4.2 to 85 N-m) 37 - 752 in. lb. (43 - 867 kg-cm)
Guaranteed Accuracy Range:	12.5 - 62.7 ft. lb. (17 - 85 N-m) 150 - 752 in. lb. (173 - 867 kg-cm)
Accuracy:	CW: ±2%; CCW: ±3%
Data Memory Size:	50
Pre-Sets:	9
LED Indicators:	6 (1 red, 5 green)
Operation Mode:	Peak hold/track
Unit Selection:	ft. lb., in. lb., N-m, kg-cm
Gear Teeth:	52
Head Open Size:	.2 - 1.18 inches (5 - 30 mm)
End Fitting Size (w x h):	.35 in. x .47 in. (9 x 12 mm)
Axial Distance:	17.5mm
Battery Type:	2 X AAA (Non-Rechargeable)
Operating Temperature:	14°F ~ 140°F (-10°C ~ 60°C)
Storage Temperature:	4°F ~ 158°F (-20°C ~ 70°C)
Humidity:	Up to 90% non-condensing
Drop Test:	1 m
Vibration Test:	10G

Solenoid Valve Service Magnet



YELLOW JACKET®



Solenoid Valve



4-Way Reversing Valve

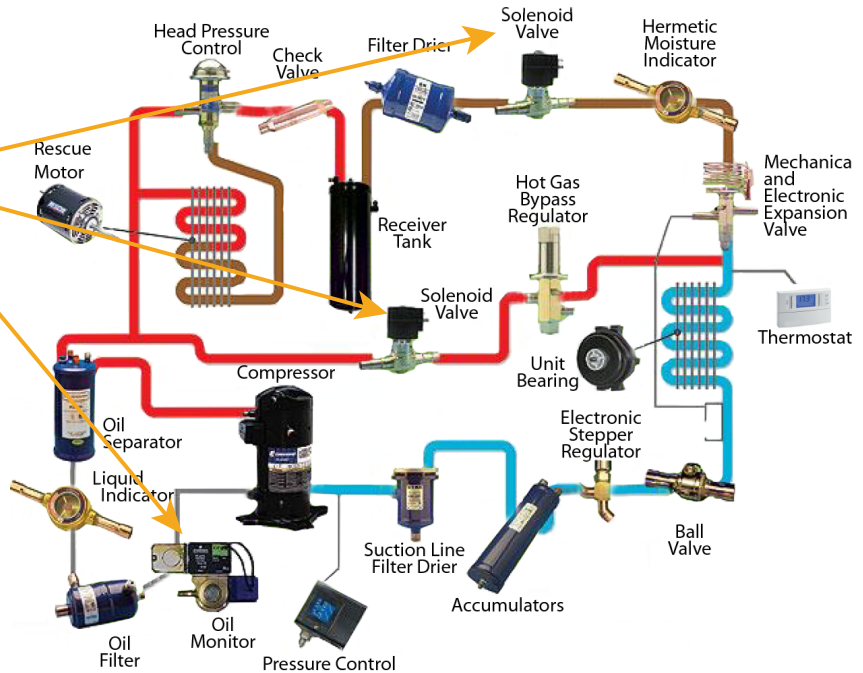

Fits most common solenoid and 4-way reversing valves.

To optimize recovery, simply remove the solenoid coil from all normally closed valves – refrigerant control valves, hot gas defrost valves, reversing valves, etc. Then apply the YELLOW JACKET® solenoid magnet to each valve to speed up recovery and evacuation.

To help isolate solenoid valve issues, remove the coil from the valve and apply the YELLOW JACKET® solenoid magnet. If the valve actuates, an electrical or solenoid coil issue is indicated. If the valve actuates but there is no flow, this indicates a plugged valve. No actuation indicates the problem is in the valve body itself.



The YELLOW JACKET® Solenoid Valve Service Magnet is the quickest and easiest way to manually operate solenoid valves. It works by magnetically lifting the stem assembly and plunger to actuate the valve during service.

Test and Control

Use this solenoid service magnet to test, troubleshoot, or manually activate and control a direct connected or pilot operated 2-way solenoid, 3-way reclaim or 4-way reversing valve typically found in a reverse cycle air conditioner or heat pump.

Recovery and Evacuation

This magnet can also be used to hold a solenoid valve open during recovery and evacuation so the entire system can be accessed.

Other Uses

- Use in place of the power head on a hot water oil shutoff valve to eliminate the need to wait for the delay on open
- Use it to temporarily replace a faulty coil to open the solenoid valve
- Use it to turn the power on or replace the solenoid if it is bad

Specifications

Opening: 0.75 in. (18 mm) fits most common manufactured valves including reversing valves.

Diameter: 1.5 in.

Length: 1.6 in.

UPC#	Description
61192	Solenoid Service Magnet