



Operation:

Flomatic 888 wafer check valves are normally installed downstream of a pump. Upon pump shut down the spring loaded valve is designed to close before reversal of flow. This will prevent flow reversal slam, which helps to eliminate water hammer and system surges associated with valve closure. On start-up, the water forces the poppet open and allows water to pass thru the valve. On shut-down the spring closes the poppet to prevent the flow reversal. The only moving parts are the poppet and spring, with the bushing guiding the poppet stem for even seating.

Installation:

Installation must be performed by qualified, licensed personnel only.

Remove all packing materials from the valve, including the tabs that stop seat from getting damaged during shipping.

The Flomatic 888 wafer check valve can be installed vertically (flow up) or horizontally. Consult factory for vertical flow down. The valve must be installed with the flow arrow on the tag pointing to the flow of water. Three diameters of straight pipe upstream of the valve are recommended to prevent turbulent flow thru the valve, which will cause vibration and wear. Valves must be mounted between ANSI B16.5 flat face flanges with 1/16 min thickness ring gaskets. Centering the valve properly is important to prevent damage to the valve and/or leakage. Never lift the valve by the bronze or stainless steel trim. Hand tighten, then torque the bolts using the cross-over flange bolt tightening method. This will load the bolts evenly and help eliminate concentrated stresses.

125# Flange			250# Flange		
Valve Size	Bolt Diameter	Bolt Torque	Valve Size	Bolt Diameter	Bolt Torque
2	5/8	25-75	2	5/8	25-75
2.5	5/8	25-75	2.5	3/4	25-75
3	5/8	25-75	3	3/4	35-75
4	3/4	30-90	4	3/4	50-150
5	3/4	30-90	5	3/4	70-150
6	3/4	30-90	6	3/4	70-150
8	3/4	40-120	8	7/8	90-200
10	7/8	45-150	10	1	110-300

Maintenance:

The Flomatic 888 wafer check valve should be serviced yearly by a qualified and licensed person only. The valve should be isolated, and the pressure in the line needs to be relieved on both sides of the valve. The outlet flange should be loosened first, then the inlet flange can be loosened to relieve line pressure. After the valve is removed, inspect the internal parts and valve body for wear or damage. Any worn or damage parts should be replaced.

Disassembly / Reassembly:

The Flomatic 888 wafer check valve can be disassembled by placing the valve arrow up on at least two 2 x 4 boards, making sure that the seat ring is not covered, so it can drop from the valve body freely. Make sure that the internals will drop on a surface that will not damage them. Hold a metal rod on the top of the stem. It should cover the stem only, not the bushing. Hit the rod with a hammer and the seat, poppet, spring and bushing will drop out of the valve. See illustration on the next page.

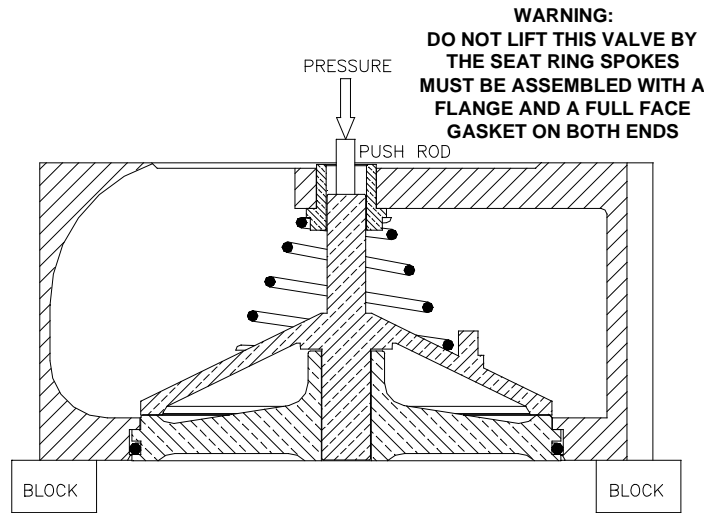

To reassemble the valve, place on a flat surface with the arrow facing down and the inlet side exposed. Place the bushing in the center hole of the spokes. Place the spring on the top of the bushing and the poppet stem thru the spring and bushing. Make sure to lubricate the seat ring o’ring (this is very important to prevent damage to the o’ring which will cause a leak, and not let the seat enter the valve). We recommend using Super Lube – which is NSF approved. Make sure to place the seat ring in valve, lining up the poppet stem thru the bushing and using both hands press on the seat ring to pop it back in. On the larger size valves a 2 x 4 can be places across the seat ring and hit with a hammer to pop it back in.

Trouble Shooting Guide	
Problem:	Possible Solutions:
Valve chatters or vibrates	Make sure the velocity is at least 4 feet per second. Noise that sounds like rocks in the line can be cavitation from high velocities, or low downstream pressure. Make sure there is at least 3 diameters of straight pipe upstream.
Valve leaks	If the seat ring is lifted above the flange face – the mating flange and gasket are not seated correctly. Re-align the valve and gaskets and tighten the bolts according to the torque chart. Also make sure that the correct size gaskets are being used.
Water does not flow thru valve	Check to make sure the arrow is in the direction of flow. Verify that the downstream isolation valve is open and there is no blockage preventing flow.
Valve Slams	Remove the valve from line and check the spring. Replace worn or damaged spring. If necessary consult the factory about purchasing a heavier spring for your conditions.

Information needed to order repair parts:

Valve Model Number

Valve Size

Valve working Pressure

Limited One Year Warranty: Flomatic valves are guaranteed against defects of material or workmanship when used for the services recommended. If, in any recommended service a defect develops due to material or workmanship, and the device is returned, freight prepaid, to Flomatic Corporation within 12 months from date of purchase, it will be repaired or replaced free of charge. Flomatic Corporations’ liability shall be limited to our agreement to repair or replacement of valve only.