

PRODUCT SPECIFICATIONS

Elkay Water Dispenser 1.5 GPH Hot Filtered Stainless Steel. Features shall include Cold Water, Filtered, Hot Water, Sparkling Water, UV Purification. Front Button activation with Dry Cooling technology. Product shall be Countertop mounted/Freestanding.

Special Features:	Cold Water, Filtered, Hot Water, Sparkling Water, UV Purification
Model Type:	Countertop
Material:	Stainless Steel
Dimensions (L x W x H):	19-3/16" x 10-1/4" x 16-7/16"
Approx. Shipping Weight:	80 lbs.
Cold Water Temperature Range:	42° F – 50° F
Cooling Capacity:	1.5 GPH (32.6 oz. cups/hour)
Cooling Technology:	Aluminum fusion block heat exchanger
Refrigerant Gas:	R134a
Condensation Control:	Forced ventilation (fan)
Hot Water Temperature:	185° F
Hot Water Tank Capacity:	0.265 gallons
Heater Rating:	1000 W
Inlet Water Line:	1/4 inch, PE plastic tubing
Electrical:	115V/60Hz
Power Consumption:	1200 W
Working Room Temperature:	Min 41° F – Max 107° F
Filter Capacity:	6000 gallons or 6 months
*Based on 68° F inlet water & 77° F ambient air temp for 50° F chilled drinking water.	

- Three water dispensing options: cold water, hot water, and sparkling water.
- Filter is certified to NSF 42 for particulate, chlorine, taste, and odor reduction.
- UV Purification system prevents growth of bacteria.
- Includes hot water safety latch.
- Drip tray: no drain line required.
- Fast fill rate 1.1 GPM.

INSTALLATION KIT

- Installation and Operating instructions
- CO₂ Regulator
- Water Pressure Regulator
- Elkay WaterSentry[®] Filter and Mounting Bracket
- Additional tubing for connection to water and CO₂
- Requires fittings for connection to water supply
- Shut-off Valve

PART: _____ QTY: _____

PROJECT: _____

CONTACT: _____

DATE: _____

NOTES: _____

APPROVAL: _____



AMERICAN PRIDE. A LIFETIME TRADITION. Like your family, the Elkay family has values and traditions that endure. For almost a century, Elkay has been a family-owned and operated company, providing thousands of jobs that support our families and communities.

Included with Product: Installation Kit

PRODUCT COMPLIANCE

CAN/CSA C22.2 No. 120
NSF/ANSI 42
UL 399



[Installation Instructions \(PDF\)](#)

[Warranty \(PDF\)](#)

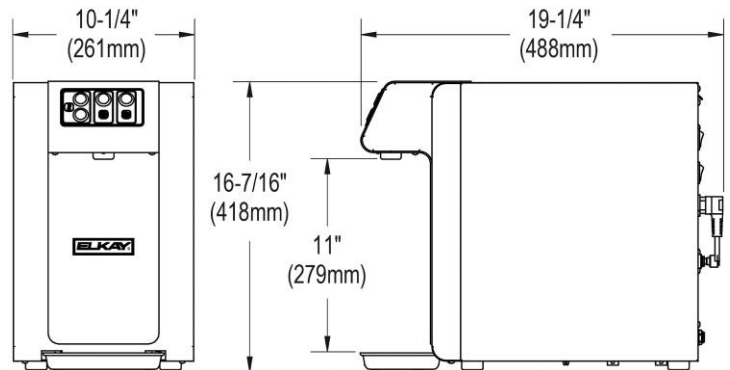

OPTIONAL ACCESSORIES

WSF6000R-2PK - WaterSentry Fresh 6000 CTO Filter - Replacement (2pack)
DSCABBSH - Elkay Water Dispenser Cabinet

In keeping with our policy of continuing product improvement, Elkay reserves the right to change product specifications without notice. Please visit elkay.com for the most current version of Elkay product specification sheets. This specification describes an Elkay product with design, quality, and functional benefits to the user. When making a comparison of other producers' offerings, be certain these features are not overlooked.