

# PresCal™

## Pre-adjustable pressure reducing valves



01265/19 NA

Replaces 01265/17 NA

### 535H series



ASSE 1003

NSF 61

#### Function

Pressure reducing valves are devices which, when installed on water systems, reduce and stabilize the pressure of the water entering from the water supply main. This pressure, in general, is too high and variable for domestic systems to operate correctly.

The 535H series pressure reducing valves, ideal for residential and commercial applications, feature a dial indicator with direct readout allowing easy pressure pre-adjustment. After installation, the valve will control at the pre-adjusted pressure setting.

The valve is constructed of DZR low-lead forged brass and incorporates a unique noise reducing and high flow seat design, is easily serviced with a replaceable cartridge and has an integral stainless steel filter (35 mesh), suitable for water systems that may contain sediment and debris.

The valve is ICC-ES certified to ASSE 1003, CSA B356, NSF 61, NSF 372, low lead laws and listed by ICC-ES. It meets codes IPC, IRC, UPC and NPC for use in accordance with the US and Canadian plumbing codes.

#### Product range

5353H series	Pre-adjustable pressure reducing valve with or without pressure gauge and NPT female threaded union connections..... sizes 1/2", 3/4", 1", 1 1/4", 1 1/2" & 2"
5355H series	Pre-adjustable pressure reducing valve with or without pressure gauge and union PEX expansion connections.....size 3/4"
5356H series	Pre-adjustable pressure reducing valve with or without pressure gauge and union press connections.....sizes 3/4" & 1"
5357H series	Pre-adjustable pressure reducing valve with or without pressure gauge and union PEX crimp connections.....sizes 3/4" & 1"
5359H series	Pre-adjustable pressure reducing valve with or without pressure gauge and union sweat connections..... sizes 1/2", 3/4", 1" & 1 1/4", 1 1/2" & 2"

#### Technical specifications

<b>Materials</b>	- body:	DZR low-lead forged brass EN 12165 CW724R
	- cover:	glass reinforced nylon PA66M40/11
	- control stem:	stainless steel EN 10088-3 (AISI 303)
	- moving parts:	DZR low-lead brass EN 12165 CW724R
	- diaphragm:	peroxide-cured EPDM
	- seals:	peroxide-cured EPDM
	- compensation piston rings:	PTFE
	- filter:	stainless steel EN 10088-2 (AISI 304)
	- seat:	stainless steel EN 10088-3 (AISI 303)
	- shuttle:	PPSG40

#### Performance

Suitable fluids:	water
Max. working pressure:	300 psi (20 bar)
Downstream pressure setting range:	15 - 90 psi (1 - 6 bar)
Factory setting:	45 psi (3 bar)
Maximum working temperature:	180°F (80°C)
Flow rates at 6 fps (gpm):	1/2": 7.3; 3/4": 12.5; 1": 19.0; 1 1/4": 34.0; 1 1/2": 44.0; 2": 70.0
Pressure gauge scale:	0 - 100 psi (0 - 7 bar)
Filter mesh size:	0.51 mm (35 mesh)

#### Certifications

1. Complies with codes IPC, IRC, UPC and NPC. ICC-ES certified to ASSE 1003, CSA B356 (R2015), and NSF/ANSI 61, file PMG-1356.
2. NSF/ANSI 372, Drinking Water System Components-Lead Content Reduction of Lead in Drinking Water Act, California Health and Safety Code 116875 S.3874, Reduction in Drinking Water Act, Vermont Act 193 - The Lead in Plumbing Supplies Law and Maryland's Lead Free Law HB.372, certified by ICC-ES, file PMG-1360.
3. PEX crimp fittings certified to ASTM F 1807.
4. PEX expansion fittings certified to ASTM F 1960.

#### Connections

Main connections:	1/2", 3/4", 1", 1 1/4", 1 1/2" & 2" NPT female and sweat union 3/4" PEX expansion union 3/4" & 1" press and PEX crimp union
-------------------	---

**Dimensions**

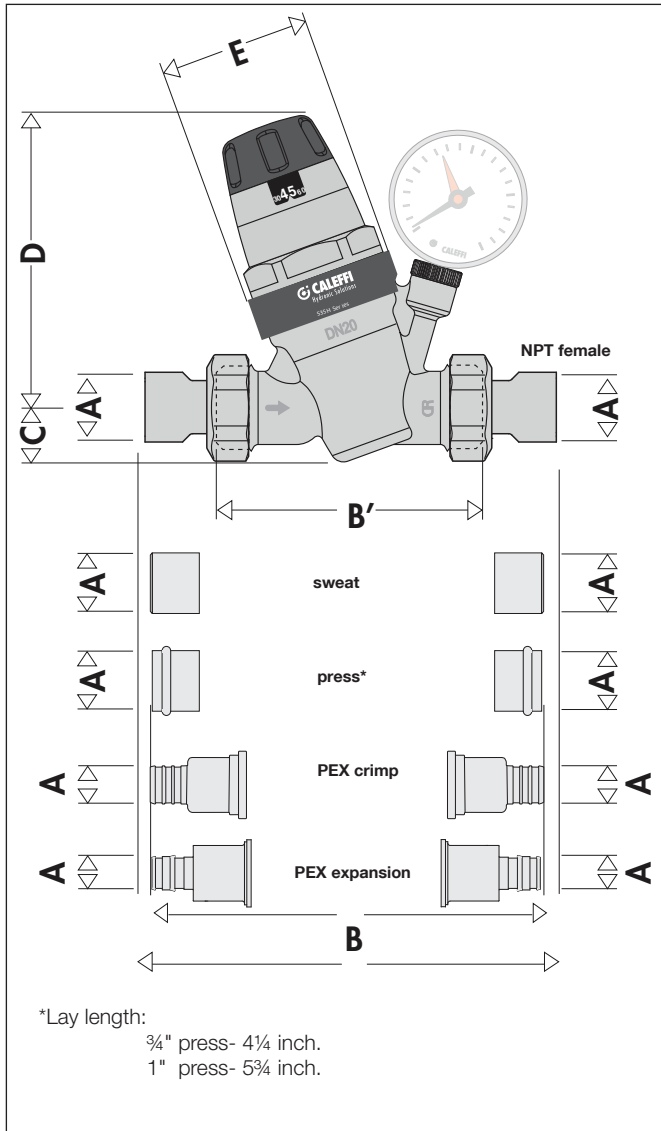

**PVC jumper nipple**



PVC jumper nipple with male union thread. The length of the jumper nipple matches the 535HA series valve body face-to-face dimension (B'), allowing the piping to be completed prior to the installation of valve and permitting quick change out from the jumper to the valve.

Code	Description	Wt (lbs)
NA11304	Jumper nipple for 535HA 1/2" series	0.1
NA11305	Jumper nipple for 535HA 3/4" series	0.1
NA11306	Jumper nipple for 535HA 1" series	0.2
NA11307	Jumper nipple for 535HA 1 1/4" series	0.3
NA11308	Jumper nipple for 535HA 1 1/2" series	0.3
NA11309	Jumper nipple for 535HA 1 3/4" series	0.5

Code	A	B	B'	C	D	E	Wt (lb)
535940HA	1/2" swt	5 5/8"	3"	13/16"	4 1/2"	2 3/8"	1.9
535941HA	1/2" swt*	5 5/8"	3"	13/16"	4 1/2"	2 3/8"	2.0
535340HA	1/2" nptf	5 3/4"	3"	13/16"	4 1/2"	2 3/8"	2.0
535341HA	1/2" nptf*	5 3/4"	3"	13/16"	4 1/2"	2 3/8"	2.1
535950HA	3/4" swt	5 5/8"	3 9/16"	13/16"	4 1/2"	2 3/8"	2.2
535951HA	3/4" swt*	5 5/8"	3 9/16"	13/16"	4 1/2"	2 3/8"	2.3
535350HA	3/4" nptf	6 5/16"	3 9/16"	13/16"	4 1/2"	2 3/8"	2.3
535351HA	3/4" nptf*	6 5/16"	3 9/16"	13/16"	4 1/2"	2 3/8"	2.4
535650HA	3/4" press	6 1/4"	3 9/16"	13/16"	4 1/2"	2 3/8"	2.3
535651HA	3/4" press*	6 1/4"	3 9/16"	13/16"	4 1/2"	2 3/8"	2.4
535750HA	3/4" PEX crimp	7"	3 9/16"	13/16"	4 1/2"	2 3/8"	2.3
535751HA	3/4" PEX crimp*	7"	3 9/16"	13/16"	4 1/2"	2 3/8"	2.4
535550HA	3/4" PEX expansion	7 3/4"	3 9/16"	13/16"	4 1/2"	2 3/8"	2.3
535551HA	3/4" PEX expansion*	7 3/4"	3 9/16"	13/16"	4 1/2"	2 3/8"	2.4
535960HA	1" swt	6 7/8"	3 3/4"	13/16"	4 1/2"	2 3/8"	2.9
535961HA	1" swt*	6 7/8"	3 3/4"	13/16"	4 1/2"	2 3/8"	3.0
535360HA	1" nptf	7 1/16"	3 3/4"	13/16"	4 1/2"	2 3/8"	3.0
535361HA	1" nptf*	7 1/16"	3 3/4"	13/16"	4 1/2"	2 3/8"	3.1
535660HA	1" press	7 3/4"	3 3/4"	13/16"	4 1/2"	2 3/8"	3.0
535661HA	1" press*	7 3/4"	3 3/4"	13/16"	4 1/2"	2 3/8"	3.1
535760HA	1" Pex crimp	6 1/4"	3 3/4"	13/16"	4 1/2"	2 3/8"	3.0
535761HA	1" Pex crimp*	6 1/4"	3 3/4"	13/16"	4 1/2"	2 3/8"	3.1
535970HA	1 1/4"swt	7 7/8"	4 5/16"	1-9/16"	7"	3-1/16"	5.6
535971HA	1 1/4"swt*	7 7/8"	4 5/16"	1-9/16"	7"	3-1/16"	5.7
535370HA	1 1/4"nptf	7 7/8"	4 5/16"	1-9/16"	7"	3-1/16"	5.7
535371HA	1 1/4" nptf*	7 7/8"	4 5/16"	1-9/16"	7"	3-1/16"	5.8
535980HA	1 1/2"swt	7 9/16"	4 3/4"	1 1/2"	7"	3-1/16"	7.3
535981HA	1 1/2"swt*	7 9/16"	4 3/4"	1 1/2"	7"	3-1/16"	7.4
535380HA	1 1/2"nptf	7 7/8"	4 3/4"	1 1/2"	7"	3-1/16"	7.3
535381HA	1 1/2" nptf*	7 7/8"	4 3/4"	1 1/2"	7"	3-1/16"	7.4

NOTE:

\*configuration includes factory supplied outlet pressure gauge.

## Operating principle

Operation of the pressure reducing valve is based on the balance between two opposing forces:

1 The force of the spring towards the opening of the valve.

2 The force of the diaphragm towards the closure of the valve.

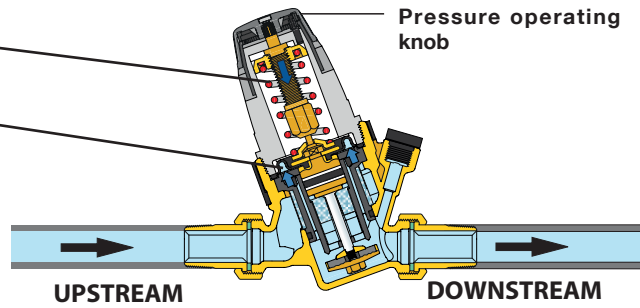

### Operation with water flow

When a faucet is opened on the water system, the force of the spring becomes greater than that of the diaphragm; the shuttle moves downwards opening the valve to the flow of water. The greater the demand for water the lower the pressure under the diaphragm with a resulting greater flow of water through the valve.

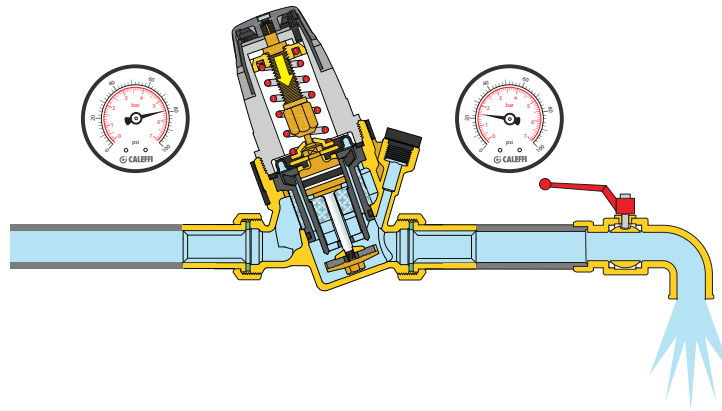

### Operation without water flow

When the faucet is closed, the downstream pressure rises and pushes the diaphragm upwards. As a result the shuttle closes the valve to the flow of water and maintains the pressure at the pressure setting. The slight difference between the force of the diaphragm compared to that of the spring causes the valve to close.

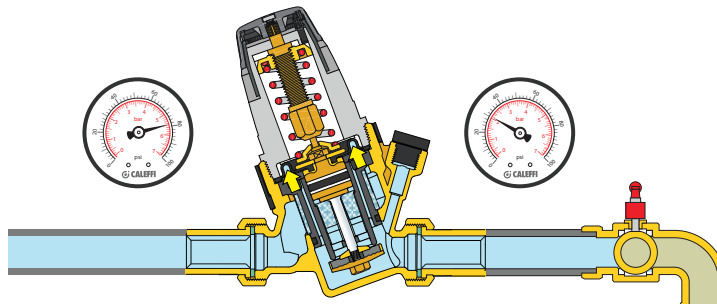

## Construction details

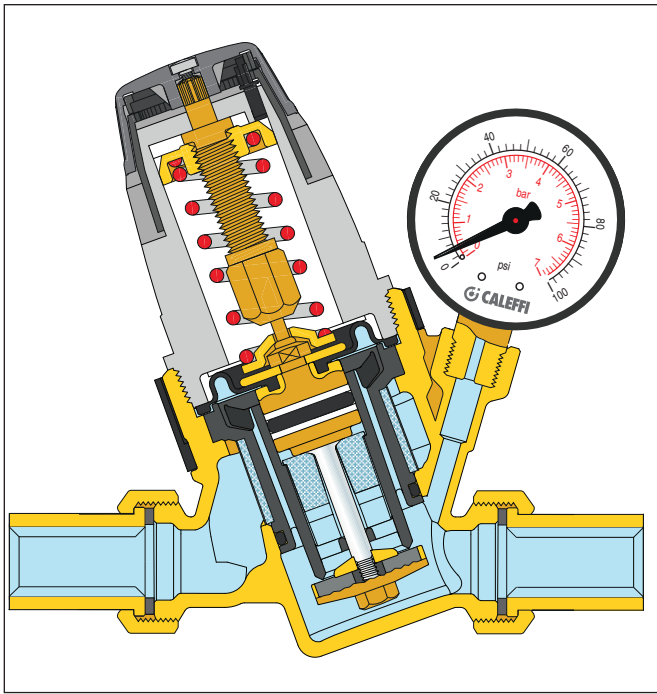

### Pre-adjustment

Caleffi 535H series pressure reducing valves have an operating knob and a pressure setting indicator which is visible on both sides. This pressure indicator features incremental step operation, where the pressure can be adjusted continuously with the value displayed at 15 psi increments. The pressure can be pre-set to the desired value, even before the pressure reducing valve is installed.

### Adjustment lock

Tighten the screw in the top of the set point knob to prevent tampering.

### Pressure balanced seat

Caleffi 535H series pressure reducing valves are designed with pressure balanced seats. This means the setting pressure value remains constant, regardless of variations in the upstream pressure value. In the figure, the thrust towards the opening is counterbalanced by the force created by the closing pressure acting on the compensating piston. Since the piston has a surface area equal to that of the shuttle, the two forces cancel out each other.

The special cross-section of the flow path between the seat and shuttle seal stabilizes upstream pressure fluctuations and high flow rates, reducing noise levels caused by the flowing water.

### Low head losses

The large cross-section flow chamber of the 535H series pressure reducing valve minimizes pressure drop within the valve which results in superior falloff pressure, enabling more flow capacity to fixtures.

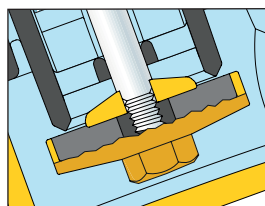
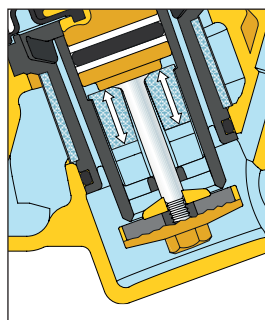
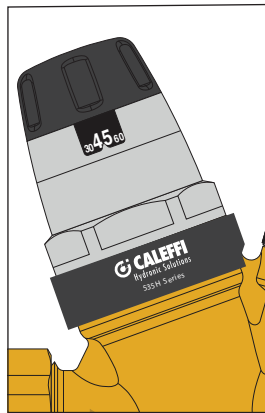

## Working pressures

The zone exposed to upstream pressure is constructed so that it can operate at high pressure. The PTFE heavy duty rings on the compensating piston make it possible for the valve to be used continuously at upstream pressures up to 300 psi.

## Non-sticking materials

The central support assembly, containing moving parts, is made of plastic material with a low adherence coefficient. This minimizes the formation of lime scale, a common cause of flow inconsistencies.

## Stainless steel stem

The stainless steel stem minimizes the harmful affects associated with the use of hard and aggressive water.

## Contoured diaphragm

The diaphragm is designed with a special shape to assure more accurate pressure regulation in accordance with downstream pressure fluctuations.

This feature also extends the life of the valve, since the diaphragm is more resistant to sudden pressure fluctuations and to normal wear.

## Compact dimensions

The "inclined" configuration makes the 535HA series pressure reducing valves compact for easy installation, especially in domestic water systems.

## Removable self-contained cartridge

The cartridge containing the diaphragm, filter, seat, shuttle and compensating piston is a pre-assembled self-contained unit with a cover, and can be removed to facilitate inspection and maintenance procedures.

The special construction of the regulating element does not require any modification of the setting pressure value, which may be left unchanged.

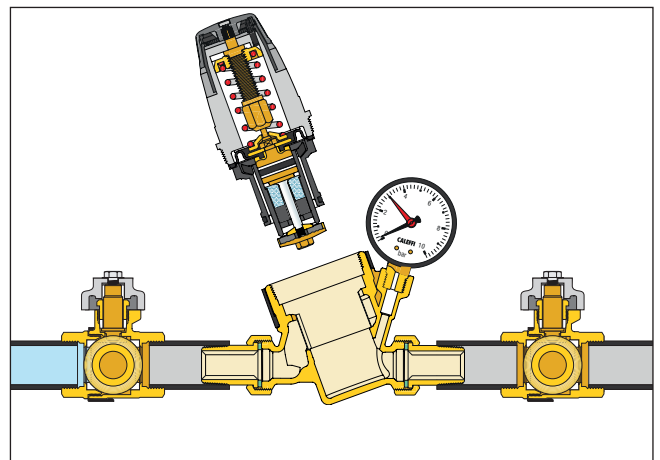

## High temperatures

The materials used for the construction of the 535H series pressure reducing valves allow installation also on hot water booster circuits with temperatures up to 180°F (80°C).

## Pressure gauge

The pressure gauge (optional) shows the exact downstream pressure value regardless of the adjusted knob pressure setting. For special conditions, e.g. in the presence of a downstream water heater, the pressure may rise above the set value.

## Certification

1. ICC-ES certified to ASSE 1003, CSA B356, NSF 61 and NSF 372.
2. NSF/ANSI 372-2011, Drinking Water System Components-Lead Content Reduction of Lead in Drinking Water Act, California Health and Safety Code 116875 S.3874, Reduction in Drinking Water Act, certified by ICC-ES, file PMG-1360.

Graph 1 (Circulation speed)

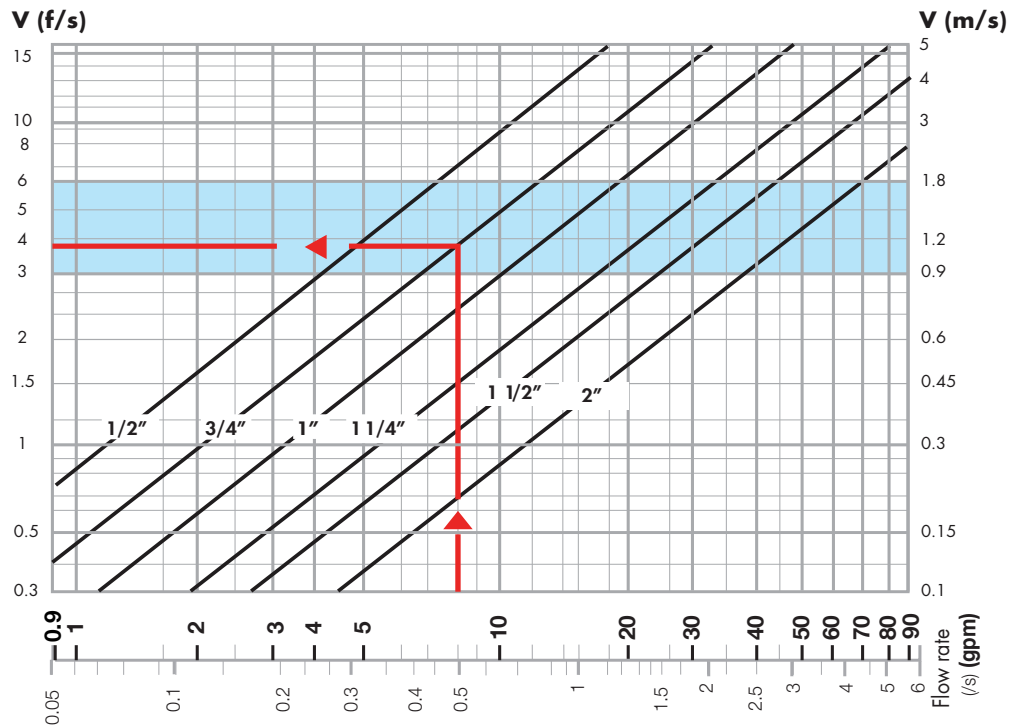

Graph 2 (Pressure drop)

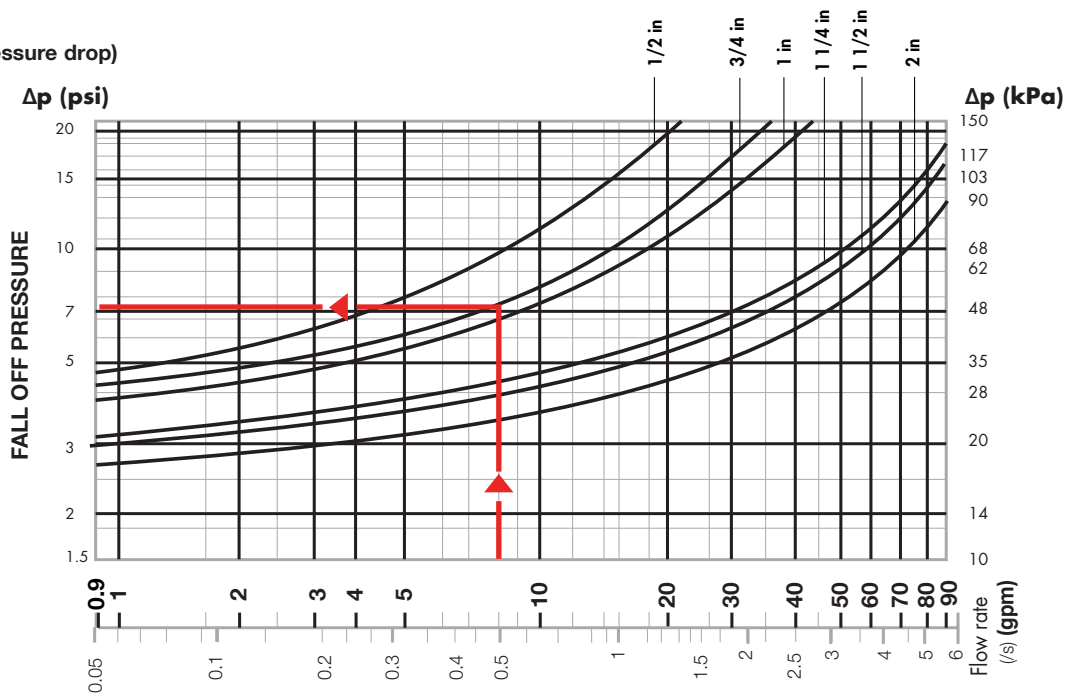

Reference values: Upstream pressure = 116 psi (800 kPa)  
Downstream pressure = 43 psi (300 kPa)

**Sizing procedure**

Flow velocity is recommended to be kept within 3 to 6 feet per second when calculating the correct pressure reducing valve size. This will prevent noise in the pipes and rapid wear of appliances.

The correct diameter of the pressure reducing valve is taken from graph 1 on the basis of the design flow rate taking into account an ideal flow velocity in the valve body of between 3 and 6 f/s (blue band).

The pressure drop is taken from graph 2 also on the basis of where the design flow rate intersects the curve for the valve size already selected (the downstream pressure falls by an amount equal to the pressure drop, with respect to the set pressure at no flow condition).

Example:  
For 8 gpm the  $\Delta p = 7.3$  psi (see arrow on graph 2).

Example:  
For 8 gpm, select the 3/4" size valve (see arrow on graph 1).

	Design Flow Rate					
Size	1/2"	3/4"	1"	1 1/4"	1 1/2"	2"
gpm	4 to 7.3	7 to 12.5	10 to 19	17 to 34	24 to 44	37 to 70

## Installation

- 1) Turn all the faucets on before installing the pressure reducing valve, to flush the system and expel any air remaining in the pipes.
- 2) Install shut-off valves upstream and downstream to facilitate maintenance operations.
- 3) The pressure reducing valve may be installed on either vertical or horizontal pipe. However, it must not be installed upside down.

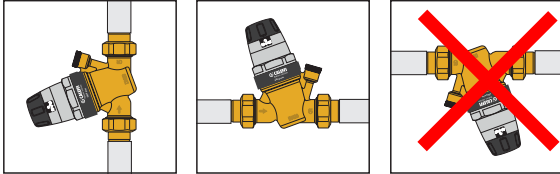

- 4) Close the downstream shut-off valve.
- 5) This mechanical pre-adjustment system, with the operating knob and pressure indicator visible from both sides, allows the pressure reducing valve to be set to the required value in the system prior to installation. The pressure indicator features incremental step operation, where the pressure can be adjusted continuously with the value displayed at 15 psi increments.
- 6) Set the pressure using the operating knob on the upper part of the valve. The pressure reducing valves are factory set to a pressure of 45 psi.
- 7) Because the pre-adjustment dial displays in 15 psi increments, the optional downstream outlet pressure gauge can be used to show the exact outlet pressure, which is especially useful for applications requiring this precision.
- 8) After installation, the internal mechanism will automatically control the pressure, until the set value has been reached.
- 9) Slowly reopen the downstream shut-off valve.

## Installation recommendations

### 1. Installation below ground

Installation below the ground is not advisable.

### 2. Outdoor installation

Pressure reducing valves should not be installed outside the building unless properly protected from freezing and the weather.

### 3. Water hammer

Water hammer is a common reason for pressure reducing valve failures. Specific devices should be installed to absorb water hammer for systems with this risk.

## Troubleshooting

System failures are not always caused by the pressure reducing valve. Most frequently:

### 1. Increased downstream pressure in the presence of a water heater

If the downstream pressure increases beyond the desired setting due to an inline water heater, install an expansion tank between the pressure reducing valve and the water heater to absorb the increased pressure, caused by water expansion from heating.

### 2. The pressure reducing valve does not maintain downstream setting value

If the pressure reducing valve does not maintain the downstream setting, it most likely is due to impurities accumulating on the valve seat, causing unnecessary flow to pass-through, increasing the downstream pressure. Proper maintenance and cleaning of the removable cartridge is recommended.

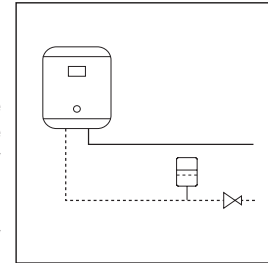

## Application diagrams

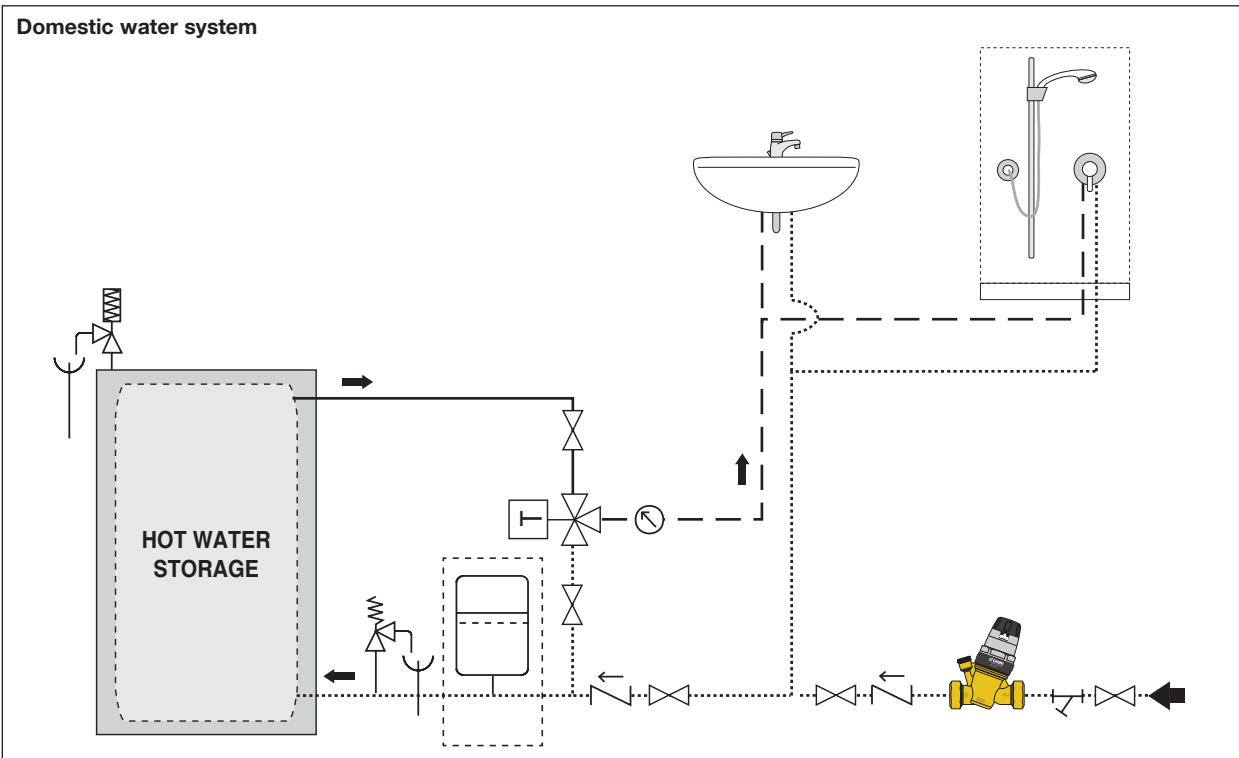

Distribution circuit with booster pump

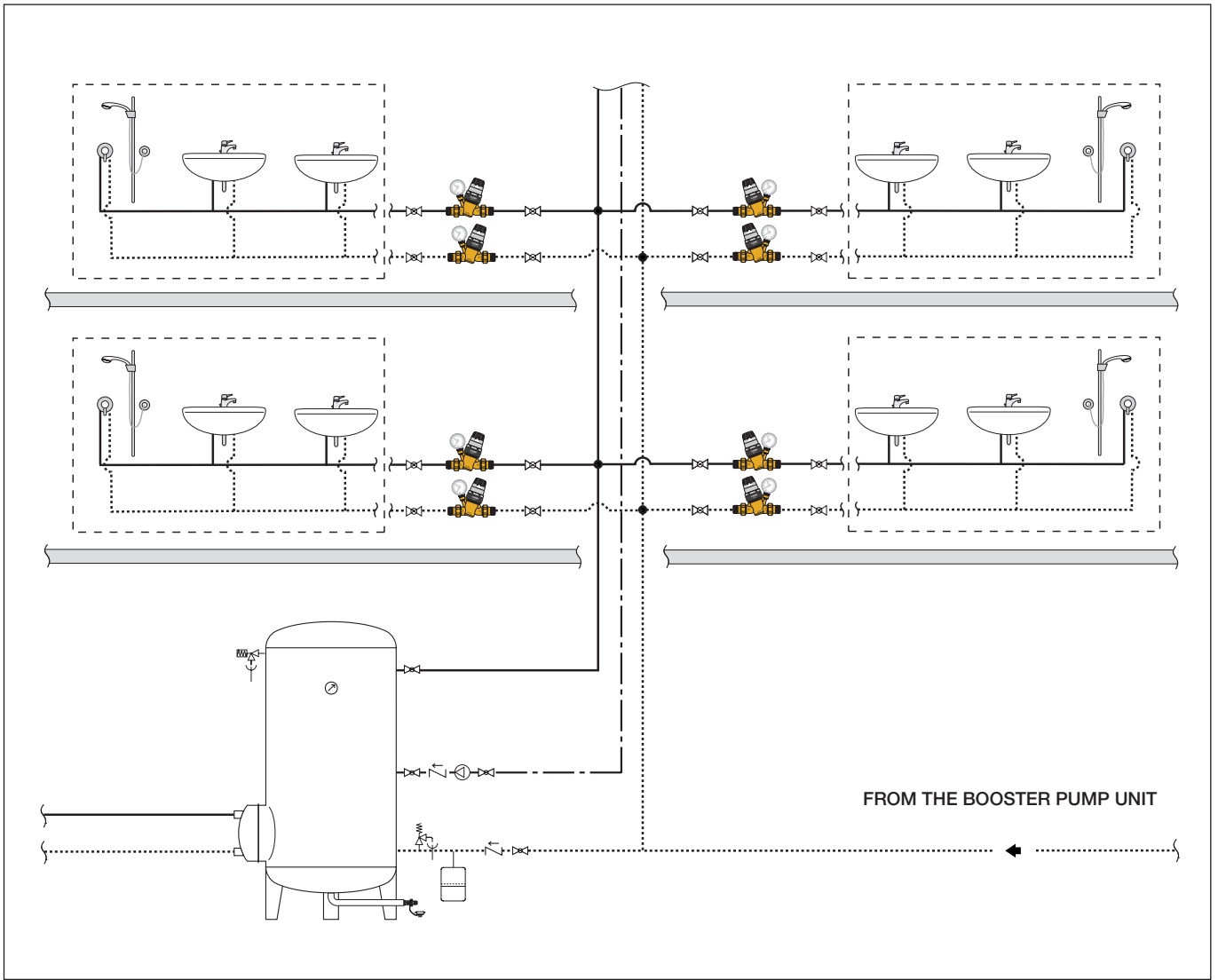

## Replacement parts



Replacement cartridge for PresCal 535H series pressure reducing valve.

535006HA .....fits 535H 1/2", 3/4" 1"

535007HA.....fits 535H 1 1/4", 1 1/2", 2"

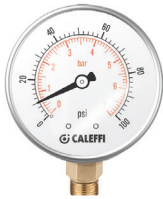

Pressure gauge fits 535H series pressure reducing valves. Pressure range 0 to 100 psi (0 to 7 bar).

NA10273.....1/8" NPT male

## SPECIFICATION SUMMARY

### 535H series

Pre-adjustable pressure reducing valve with pressure balanced seat and self-contained cartridge, certified by ICC-ES to ASSE 1003, CSA B356, NSF 61 and NSF 372. Meets codes IPC, IRC and UPC for use in accordance with the US and Canadian plumbing codes. Sizes 1/2" to 2" with NPT female union or sweat union connections, sizes 3/4" to 1" press union connections, sizes 3/4" to 1" PEX crimp union connections and size 3/4" PEX expansion union connections. PEX crimp fittings must comply with ASTM F 1807. PEX expansion fittings must comply with ASTM F 1960. Dezincification resistant low-lead forged brass body (<0.25% Lead content) certified by and listed by ICC-ES. DZR low-lead brass internal moving parts. Cover in glass reinforced nylon PA66M40/1. Stainless steel filter, mesh size 0.51 mm (35 mesh). Peroxide-cured EPDM membrane and sealing gaskets. PTFE compensating piston rings. Maximum working temperature 180 degrees F (80 degrees C). Maximum upstream pressure 300 psi (20 bar). Downstream pressure setting range from 15 psi to 90 psi (1 bar to 6 bar). Self-contained cartridge removable for maintenance purposes. Equipped with: operating knob with downstream pressure adjustment scale for manual setting and tamper-proof adjustment locking screw, pressure gauge with 0 psi to 100 psi (0 bar–10 bar) pressure scale (version with pressure gauge). Pressure gauge connection 1/8" NPT female (version without pressure gauge).

We reserve the right to make changes and improvements to the products and related data in this publication, at any time and without prior notice.



Caleffi North America, Inc.  
3883 W. Milwaukee Road  
Milwaukee, WI 53208  
Tel: 414-238-2360 · Fax: 414-238-2366  
sales@caleffi.com · www.caleffi.com  
© Copyright 2019 Caleffi North America, Inc.