

Definitions: Safety Alert Symbols and Words

This instruction manual uses the following safety alert symbols and words to alert you to hazardous situations and your risk of personal injury or property damage.



DANGER: Indicates an imminently hazardous situation which, if not avoided, **will** result in **death or serious injury**.



WARNING: Indicates a potentially hazardous situation which, if not avoided, **could** result in **death or serious injury**.



CAUTION: Indicates a potentially hazardous situation which, if not avoided, **may** result in **minor or moderate injury**.



(Used without word) Indicates a safety related message.

NOTICE: Indicates a practice **not related to personal injury** which, if not avoided, **may** result in **property damage**.

Fig. A

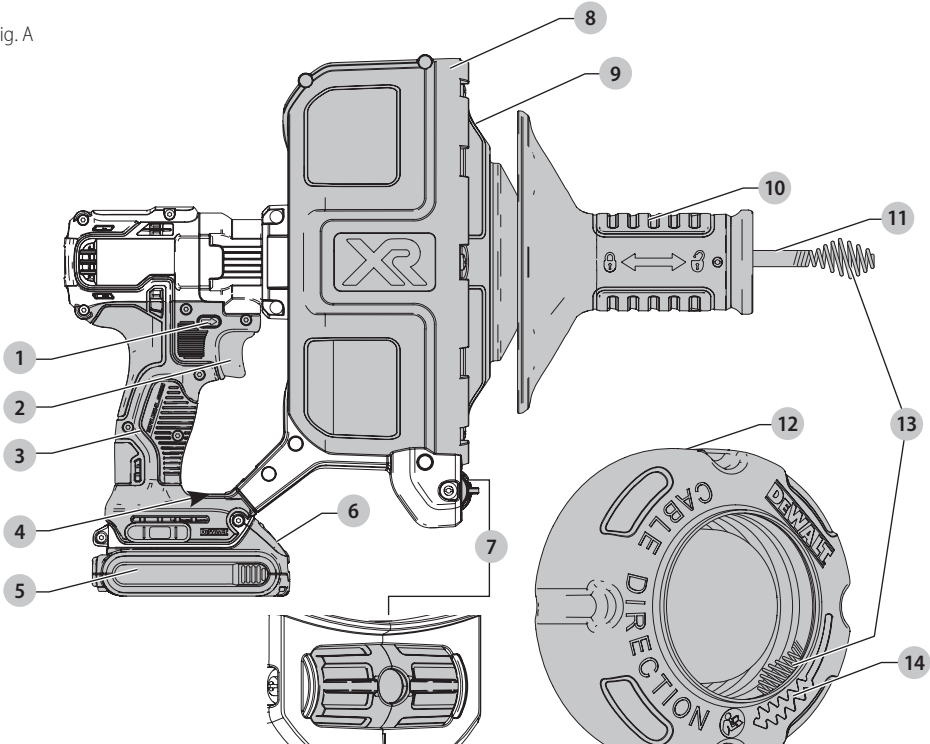

- 1 Forward/reverse control button
- 2 Variable speed trigger switch
- 3 Main handle
- 4 Worklight switch
- 5 Battery pack
- 6 Battery release button
- 7 Adjustable LED Worklight
- 8 Fixed drum shield
- 9 Drum cover
- 10 Front hand grip
- 11 Cable
- 12 Inner drum
- 13 Cable bulb end
- 14 Cable direction symbol



WARNING! Read all safety warnings and all instructions. Failure to follow the warnings and instructions may result in electric shock, fire and/or serious injury.



WARNING: To reduce the risk of injury, read the instruction manual.

If you have any questions or comments about this or any DeWALT tool, call us toll free at: 1-800-4-DeWALT (1-800-433-9258).

GENERAL POWER TOOL SAFETY WARNINGS



WARNING! Read all safety warnings and all instructions. Failure to follow the warnings and instructions may result in electric shock, fire and/or serious injury.

SAVE ALL WARNINGS AND INSTRUCTIONS FOR FUTURE REFERENCE

The term "power tool" in the warnings refers to your mains-operated (corded) power tool or battery-operated (cordless) power tool.

1) Work Area Safety

- a) **Keep work area clean and well lit.** Cluttered or dark areas invite accidents.
- b) **Do not operate power tools in explosive atmospheres, such as in the presence of flammable liquids, gases or dust.** Power tools create sparks which may ignite the dust or fumes.
- c) **Keep children and bystanders away while operating a power tool.** Distractions can cause you to lose control.

2) Electrical Safety

- a) **Power tool plugs must match the outlet. Never modify the plug in any way. Do not use any adapter plugs with earthed (grounded) power tools.** Unmodified plugs and matching outlets will reduce risk of electric shock.
- b) **Avoid body contact with earthed or grounded surfaces such as pipes, radiators, ranges and refrigerators.** There is an increased risk of electric shock if your body is earthed or grounded.
- c) **Do not expose power tools to rain or wet conditions.** Water entering a power tool will increase the risk of electric shock.
- d) **Do not abuse the cord. Never use the cord for carrying, pulling or unplugging the power tool. Keep cord away from heat, oil, sharp edges or moving parts.** Damaged or entangled cords increase the risk of electric shock.
- e) **When operating a power tool outdoors, use an extension cord suitable for outdoor use.** Use of a cord suitable for outdoor use reduces the risk of electric shock.
- f) **If operating a power tool in a damp location is unavoidable, use a ground fault circuit interrupter (GFCI) protected supply.** Use of a GFCI reduces the risk of electric shock.

3) Personal Safety

- a) **Stay alert, watch what you are doing and use common sense when operating a power tool. Do not use a power tool while you are tired or under the influence of drugs, alcohol or medication.** A moment of inattention while operating power tools may result in serious personal injury.

- b) **Use personal protective equipment. Always wear eye protection.** Protective equipment such as dust mask, non-skid safety shoes, hard hat, or hearing protection used for appropriate conditions will reduce personal injuries.
- c) **Prevent unintentional starting. Ensure the switch is in the off position before connecting to power source and/or battery pack, picking up or carrying the tool.** Carrying power tools with your finger on the switch or energizing power tools that have the switch on invites accidents.
- d) **Remove any adjusting key or wrench before turning the power tool on.** A wrench or a key left attached to a rotating part of the power tool may result in personal injury.
- e) **Do not overreach. Keep proper footing and balance at all times.** This enables better control of the power tool in unexpected situations.
- f) **Dress properly. Do not wear loose clothing or jewelry. Keep your hair, clothing and gloves away from moving parts.** Loose clothes, jewelry or long hair can be caught in moving parts.
- g) **If devices are provided for the connection of dust extraction and collection facilities, ensure these are connected and properly used.** Use of dust collection can reduce dust-related hazards.

4) Power Tool Use and Care

- a) **Do not force the power tool. Use the correct power tool for your application.** The correct power tool will do the job better and safer at the rate for which it was designed.
- b) **Do not use the power tool if the switch does not turn it on and off.** Any power tool that cannot be controlled with the switch is dangerous and must be repaired.
- c) **Disconnect the plug from the power source and/or the battery pack from the power tool before making any adjustments, changing accessories, or storing power tools.** Such preventive safety measures reduce the risk of starting the power tool accidentally.
- d) **Store idle power tools out of the reach of children and do not allow persons unfamiliar with the power tool or these instructions to operate the power tool.** Power tools are dangerous in the hands of untrained users.
- e) **Maintain power tools. Check for misalignment or binding of moving parts, breakage of parts and any other condition that may affect the power tool's operation. If damaged, have the power tool repaired before use.** Many accidents are caused by poorly maintained power tools.
- f) **Keep cutting tools sharp and clean.** Properly maintained cutting tools with sharp cutting edges are less likely to bind and are easier to control.
- g) **Use the power tool, accessories and tool bits, etc. in accordance with these instructions, taking**

into account the working conditions and the work to be performed. Use of the power tool for operations different from those intended could result in a hazardous situation.

5) Battery Tool Use and Care

- a) **Recharge only with the charger specified by the manufacturer.** A charger that is suitable for one type of battery pack may create a risk of fire when used with another battery pack.
- b) **Use power tools only with specifically designated battery packs.** Use of any other battery packs may create a risk of injury and fire.
- c) **When battery pack is not in use, keep it away from other metal objects, like paper clips, coins, keys, nails, screws, or other small metal objects, that can make a connection from one terminal to another.** Shorting the battery terminals together may cause burns or a fire.
- d) **Under abusive conditions, liquid may be ejected from the battery; avoid contact. If contact accidentally occurs, flush with water. If liquid contacts eyes, additionally seek medical help.** Liquid ejected from the battery may cause irritation or burns.

6) Service

- a) **Have your power tool serviced by a qualified repair person using only identical replacement parts.** This will ensure that the safety of the power tool is maintained.

Additional Safety Rules for Drain Snake

- Only grasp the cable with snug fitting leather work gloves with latex gloves inside. Latex or loose fitting gloves or rags can become wrapped around the cable and may result in serious personal injury.
- Stop the tool immediately if the cable binds and stops. The cable can twist, kink or break if overstressed.
- Before starting work, know what is in the drain. Wear safety equipment appropriate for the job (goggles, face shields, protective clothing, respirator, etc.). Drains may contain hazardous chemicals or infectious substances that could cause serious injury. Contact the chemical manufacturers to get safety information.
- Do not eat or smoke while handling or operating the drain snake. After handling or operating drain snake, use hot, soapy water to wash hands and other body parts exposed to drain contents. This will help reduce the risk of health hazards due to exposure to hazardous chemicals or infectious substances.
- Inspect cable for wear and damage before use.
- If the cable is worn or damaged, replace the cable before using the drain snake.
- Do not twist, kink or over bend cables. A broken cable may result in serious personal injury.
- Refer to the **Cable Application Chart** to identify the appropriate size cable for the application. An incorrect cable can twist, kink or break if overstressed.

- The drain cleaning process can damage floors and other surfaces and can be messy. Use appropriate protective covers to prevent damage and hazards to surrounding area.
- The front of the drain snake should be no farther than 6" (15 cm) from drain opening. If not possible, use additional pipe and fittings to extend the drain. Exposing more than 6" (15 cm) of cable can cause twisting, kinking, breaking or whipping of the cable.
- This tool is intended to be used by a single operator, so that they alone are able to control feed and rotation of the cable. If the cable stops rotating, the user must immediately release the trigger to prevent twisting, kinking, breaking or whipping of the cable.
- Operate the drain snake in reverse rotation only as described in this manual. Running the tool in reverse for extended periods can cause damage to the cable.
- Do not pull the trigger with the end of the cable outside of the pipe.

Additional Safety Information



WARNING: ALWAYS use safety glasses. Everyday eyeglasses are NOT safety glasses. Also use face or dust mask if cutting operation is dusty. **ALWAYS WEAR CERTIFIED SAFETY EQUIPMENT:**

- ANSI Z87.1 eye protection (CAN/CSA Z94.3),
- ANSI S12.6 (S3.19) hearing protection,
- NIOSH/OSHA/MSHA respiratory protection.



WARNING: Some dust created by power sanding, sawing, grinding, drilling, and other construction activities contains chemicals known to the State of California to cause cancer, birth defects or other reproductive harm. Some examples of these chemicals are:

- lead from lead-based paints,
- crystalline silica from bricks and cement and other masonry products, and
- arsenic and chromium from chemically-treated lumber.

Your risk from these exposures varies, depending on how often you do this type of work. To reduce your exposure to these chemicals: work in a well ventilated area, and work with approved safety equipment, such as those dust masks that are specially designed to filter out microscopic particles.

- **Avoid prolonged contact with dust from power sanding, sawing, grinding, drilling, and other construction activities. Wear protective clothing and wash exposed areas with soap and water.** Allowing dust to get into your mouth, eyes, or lay on the skin may promote absorption of harmful chemicals.



WARNING: Use of this tool can generate and/or disperse dust, which may cause serious and permanent respiratory or other injury. Always use NIOSH/OSHA approved respiratory protection appropriate for the dust exposure. Direct particles away from face and body.

ENGLISH

WARNING: Always wear proper personal hearing protection that conforms to ANSI S12.6 (S3.19) during use. Under some conditions and duration of use, noise from this product may contribute to hearing loss.

CAUTION: When not in use, place tool on its side on a stable surface where it will not cause a tripping or falling hazard. Some tools with large battery packs will stand upright on the battery pack but may be easily knocked over.

- Air vents often cover moving parts and should be avoided. Loose clothes, jewelry or long hair can be caught in moving parts.

The label on your tool may include the following symbols. The symbols and their definitions are as follows:

Table with 2 columns: Symbol and Definition. Symbols include V, Hz, min, DC, Class I, n0, n, earthing terminal, safety alert, visible radiation, wear respiratory, wear eye, wear hearing, read all, and cable direction.

BATTERIES AND CHARGERS

The battery pack is not fully charged out of the carton. Before using the battery pack and charger, read the safety instructions below and then follow charging procedures outlined. When ordering replacement battery packs, be sure to include the catalog number and voltage. Your tool uses a DeWALT charger. Be sure to read all safety instructions before using your charger. Consult the chart at the end of this manual for compatibility of chargers and battery packs.

READ ALL INSTRUCTIONS

Important Safety Instructions for All Battery Packs

WARNING: Read all safety warnings and all instructions for the battery pack, charger and power tool. Failure to follow the warnings and instructions may result in electric shock, fire and/or serious injury.

- Do not charge or use the battery pack in explosive atmospheres, such as in the presence of flammable

liquids, gases or dust. Inserting or removing the battery pack from the charger may ignite the dust or fumes.

- NEVER force the battery pack into the charger. DO NOT modify the battery pack in any way to fit into a non-compatible charger as battery pack may rupture causing serious personal injury. Consult the chart at the end of this manual for compatibility of batteries and chargers.
Charge the battery packs only in designated DeWALT chargers.
DO NOT splash or immerse in water or other liquids.
Do not store or use the tool and battery pack in locations where the temperature may reach or exceed 104 °F (40 °C) (such as outside sheds or metal buildings in summer). For best life store battery packs in a cool, dry location.
NOTE: Do not store the battery packs in a tool with the trigger switch locked on. Never tape the trigger switch in the ON position.
Do not incinerate the battery pack even if it is severely damaged or is completely worn out. The battery pack can explode in a fire. Toxic fumes and materials are created when lithium ion battery packs are burned.
If battery contents come into contact with the skin, immediately wash area with mild soap and water. If battery liquid gets into the eye, rinse water over the open eye for 15 minutes or until irritation ceases. If medical attention is needed, the battery electrolyte is composed of a mixture of liquid organic carbonates and lithium salts.
Contents of opened battery cells may cause respiratory irritation. Provide fresh air. If symptoms persist, seek medical attention.

WARNING: Burn hazard. Battery liquid may be flammable if exposed to spark or flame.

WARNING: Fire hazard. Never attempt to open the battery pack for any reason. If the battery pack case is cracked or damaged, do not insert into the charger. Do not crush, drop or damage the battery pack. Do not use a battery pack or charger that has received a sharp blow, been dropped, run over or damaged in any way (e.g., pierced with a nail, hit with a hammer, stepped on). Damaged battery packs should be returned to the service center for recycling.

Transportation

WARNING: Fire hazard. Do not store or carry the battery pack so that metal objects can contact exposed battery terminals. For example, do not place the battery pack in aprons, pockets, tool boxes, product kit boxes, drawers, etc., with loose nails, screws, keys, etc. Transporting batteries can possibly cause fires if the battery terminals inadvertently come in contact with conductive materials such as keys, coins, hand tools and the like. The US Department of Transportation Hazardous Material Regulations (HMR) actually prohibit

transporting batteries in commerce or on airplanes in carry-on baggage **UNLESS** they are properly protected from short circuits. So when transporting individual battery packs, make sure that the battery terminals are protected and well insulated from materials that could contact them and cause a short circuit.

Shipping the DeWALT FLEXVOLT™ Battery

The DeWALT FLEXVOLT™ battery has two modes: **Use** and **Shipping**.

Use Mode: When the FLEXVOLT™ battery stands alone or is in a DeWALT 20V Max* product, it will operate as a 20V Max* battery. When the FLEXVOLT™ battery is in a 60V Max* or a 120V Max* (two 60V Max* batteries) product, it will operate as a 60V Max* battery.

Shipping Mode: When the cap is attached to the FLEXVOLT™ battery, the battery is in Shipping Mode.

Strings of cells are electrically disconnected within the pack resulting in three batteries with a lower Watt hour (Wh) rating as compared to one battery with a higher Watt hour rating. This increased quantity of three batteries with the lower Watt hour rating can exempt the pack from certain shipping regulations that are imposed upon the higher Watt hour batteries.

The battery label indicates two Watt hour ratings (see example). Depending on how the battery is shipped, the appropriate Watt hour rating must be used to determine the applicable shipping requirements. If utilizing the shipping cap, the pack will be considered 3 batteries at the Watt hour rating indicated for "Shipping". If shipping without the cap or in a tool, the pack will be considered one battery at the Watt hour rating indicated next to "Use".

Example of Use and Shipping Label Marking

USE: 120 Wh Shipping: 3 x 40 Wh

For example, Shipping Wh rating might indicate 3 x 40 Wh, meaning 3 batteries of 40 Watt hours each. The Use Wh rating might indicate 120 Wh (1 battery implied).

Fuel Gauge Battery Packs (Fig. B)

Some DeWALT battery packs include a fuel gauge which consists of three green LED lights that indicate the level of charge remaining in the battery pack.

The fuel gauge is an indication of approximate levels of charge remaining in the battery pack according to the following indicators:

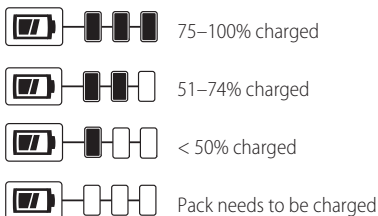

To actuate the fuel gauge, press and hold the fuel gauge button. A combination of the three green LED lights will illuminate designating the level of charge left. When the

level of charge in the battery is below the usable limit, the fuel gauge will not illuminate and the battery will need to be recharged.

Fig. B



NOTE: The fuel gauge is only an indication of the charge left on the battery pack. It does not indicate tool functionality and is subject to variation based on product components, temperature and end-user application.

For more information regarding fuel gauge battery packs, please contact call 1-800-4-DeWALT (1-800-433-9258) or visit our website www.dewalt.com.

The RBRC® Seal

The RBRC® (Rechargeable Battery Recycling Corporation) Seal on the nickel cadmium, nickel metal hydride or lithium-ion batteries (or battery packs) indicates that the costs to recycle these batteries (or battery packs) at the end of their useful life have already been paid by DeWALT. In some areas, it is illegal to place spent nickel cadmium, nickel metal hydride or lithium-ion batteries in the trash or municipal solid waste stream and the Call 2 Recycle® program provides an environmentally conscious alternative.

Call 2 Recycle, Inc., in cooperation with DeWALT and other battery users, has established the program in the United States and Canada to facilitate the collection of spent nickel cadmium, nickel metal hydride or lithium-ion batteries. Help protect our environment and conserve natural resources by returning the spent nickel cadmium, nickel metal hydride or lithium-ion batteries to an authorized DeWALT service center or to your local retailer for recycling. You may also contact your local recycling center for information on where to drop off the spent battery. RBRC® is a registered trademark of Call 2 Recycle, Inc.



Important Safety Instructions for All Battery Chargers



WARNING: Read all safety warnings and all instructions for the battery pack, charger and power tool. Failure to follow the warnings and instructions may result in electric shock, fire and/or serious injury.

- **DO NOT attempt to charge the battery pack with any chargers other than the ones in this manual.** The charger and battery pack are specifically designed to work together.
- **These chargers are not intended for any uses other than charging DeWALT rechargeable batteries.** Any other uses may result in risk of fire, electric shock or electrocution.
- **Do not expose the charger to rain or snow.**
- **Pull by the plug rather than the cord when disconnecting the charger.** This will reduce the risk of damage to the electric plug and cord.

ENGLISH

- **Make sure that the cord is located so that it will not be stepped on, tripped over or otherwise subjected to damage or stress.**
- **Do not use an extension cord unless it is absolutely necessary.** Use of improper extension cord could result in risk of fire, electric shock or electrocution.
- **When operating a charger outdoors, always provide a dry location and use an extension cord suitable for outdoor use.** Use of a cord suitable for outdoor use reduces the risk of electric shock.
- **An extension cord must have adequate wire size (AWG or American Wire Gauge) for safety.** The smaller the gauge number of the wire, the greater the capacity of the cable, that is, 16 gauge has more capacity than 18 gauge. An undersized cord will cause a drop in line voltage resulting in loss of power and overheating. When using more than one extension to make up the total length, be sure each individual extension contains at least the minimum wire size. The following table shows the correct size to use depending on cord length and nameplate ampere rating. If in doubt, use the next heavier gauge. The lower the gauge number, the heavier the cord.

Minimum Gauge for Cord Sets

Volts	Total Length of Cord in Feet (meters)				
	120 V	25 (7.6)	50 (15.2)	100 (30.5)	150 (45.7)
240 V	50 (15.2)	100 (30.5)	200 (61.0)	300 (91.4)	
Ampere Rating More Than		Not More Than		American Wire Gauge	
0	6	18	16	16	14
6	10	18	16	14	12
10	12	16	16	14	12
12	16	14	12	Not Recommended	

- **Do not place any object on top of the charger or place the charger on a soft surface that might block the ventilation slots and result in excessive internal heat.** Place the charger in a position away from any heat source. The charger is ventilated through slots in the top and the bottom of the housing.
- **Do not operate the charger with a damaged cord or plug.**
- **Do not operate the charger if it has received a sharp blow, been dropped or otherwise damaged in any way.** Take it to an authorized service center.
- **Do not disassemble the charger; take it to an authorized service center when service or repair is required.** Incorrect reassembly may result in a risk of electric shock, electrocution or fire.
- **Disconnect the charger from the outlet before attempting any cleaning. This will reduce the risk of electric shock.** Removing the battery pack will not reduce this risk.
- **NEVER** attempt to connect 2 chargers together.
- **The charger is designed to operate on standard 120V household electrical power. Do not attempt to**

use it on any other voltage. This does not apply to the vehicular charger.



WARNING: Shock hazard. Do not allow any liquid to get inside the charger. Electric shock may result.



WARNING: Burn hazard. Do not submerge the battery pack in any liquid or allow any liquid to enter the battery pack. Never attempt to open the battery pack for any reason. If the plastic housing of the battery pack breaks or cracks, return to a service center for recycling.



CAUTION: Burn hazard. To reduce the risk of injury, charge only DeWALT rechargeable battery packs. Other types of batteries may overheat and burst resulting in personal injury and property damage.

NOTICE: Under certain conditions, with the charger plugged into the power supply, the charger can be shorted by foreign material. Foreign materials of a conductive nature, such as, but not limited to, grinding dust, metal chips, steel wool, aluminum foil or any buildup of metallic particles should be kept away from the charger cavities. Always unplug the charger from the power supply when there is no battery pack in the cavity. Unplug the charger before attempting to clean.

Charging a Battery (Fig. C)

1. Plug the charger into an appropriate outlet before inserting battery pack.

Fig. C

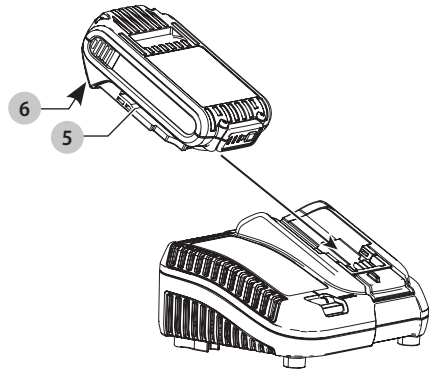

2. Insert the battery pack **5** into the charger, making sure the battery pack is fully seated in the charger. The red (charging) light will blink continuously indicating that the charging process has started.
3. The completion of charge will be indicated by the red light remaining ON continuously. The battery pack is fully charged and may be used at this time or left in the charger. To remove the battery pack from the charger, push the battery release button **6** on the battery pack.

NOTE: To ensure maximum performance and life of lithium-ion battery packs, charge the battery pack fully before first use.

Charger Operation

Refer to the indicators below for the charge status of the battery pack.

DCB107, DCB112, DCB113, DCB115, DCB118, DCB132



*DCB107, DCB112, DCB113, DCB115, DCB118, DCB132:

The red light will continue to blink, but a yellow indicator light will be illuminated during this operation. Once the battery pack has reached an appropriate temperature, the yellow light will turn off and the charger will resume the charging procedure.

The compatible charger(s) will not charge a faulty battery pack. The charger will indicate faulty battery pack by refusing to light or by displaying a problem pack or charger blink pattern.

NOTE: This could also mean a problem with a charger.

If the charger indicates a problem, take the charger and battery pack to be tested at an authorized service center.

Hot/Cold Pack Delay

When the charger detects a battery pack that is too hot or too cold, it automatically starts a Hot/Cold Pack Delay, suspending charging until the battery pack has reached an appropriate temperature. The charger then automatically switches to the pack charging mode. This feature ensures maximum battery pack life.

A cold battery pack will charge at a slower rate than a warm battery pack. The battery pack will charge at that slower rate throughout the entire charging cycle and will not return to maximum charge rate even if the battery pack warms.

The DCB118 charger is equipped with an internal fan designed to cool the battery pack. The fan will turn on automatically when the battery pack needs to be cooled.

Never operate the charger if the fan does not operate properly or if ventilation slots are blocked. Do not permit foreign objects to enter the interior of the charger.

Electronic Protection System

Li-Ion tools are designed with an Electronic Protection System that will protect the battery pack against overloading, overheating or deep discharge.

The tool will automatically turn off if the Electronic Protection System engages. If this occurs, place the lithium-ion battery pack on the charger until it is fully charged.

Wall Mounting

DCB107, DCB112, DCB113, DCB115, DCB118, DCB132

These chargers are designed to be wall mountable or to sit upright on a table or work surface. If wall mounting, locate the charger within reach of an electrical outlet, and away from a corner or other obstructions which may impede air flow. Use the back of the charger as a template for the location of the mounting screws on the wall. Mount the charger securely using drywall screws (purchased

separately) at least 1" (25.4 mm) long, with a screw head diameter of 0.28–0.35" (7–9 mm), screwed into wood to an optimal depth leaving approximately 7/32" (5.5 mm) of the screw exposed. Align the slots on the back of the charger with the exposed screws and fully engage them in the slots.

Charger Cleaning Instructions



WARNING: Shock hazard. Disconnect the charger from the AC outlet before cleaning. Dirt and grease may be removed from the exterior of the charger using a cloth or soft non-metallic brush. Do not use water or any cleaning solutions.

Important Charging Notes

- Longest life and best performance can be obtained if the battery pack is charged when the air temperature is between 65 °F and 75 °F (18 ° – 24 °C). DO NOT charge the battery pack in an air temperature below +40 °F (+4.5 °C), or above +104 °F (+40 °C). This is important and will prevent serious damage to the battery pack.
- The charger and battery pack may become warm to the touch while charging. This is a normal condition, and does not indicate a problem. To facilitate the cooling of the battery pack after use, avoid placing the charger or battery pack in a warm environment such as in a metal shed or an uninsulated trailer.
- If the battery pack does not charge properly:
 - Check operation of receptacle by plugging in a lamp or other appliance;
 - Check to see if receptacle is connected to a light switch which turns power off when you turn out the lights;
 - Move the charger and battery pack to a location where the surrounding air temperature is approximately 65 °F – 75 °F (18 ° – 24 °C);
 - If charging problems persist, take the tool, battery pack and charger to your local service center.
- The battery pack should be recharged when it fails to produce sufficient power on jobs which were easily done previously. DO NOT CONTINUE to use under these conditions. Follow the charging procedure. You may also charge a partially used pack whenever you desire with no adverse effect on the battery pack.
- Foreign materials of a conductive nature such as, but not limited to, grinding dust, metal chips, steel wool, aluminum foil, or any buildup of metallic particles should be kept away from charger cavities. Always unplug the charger from the power supply when there is no battery pack in the cavity. Unplug the charger before attempting to clean.
- Do not freeze or immerse the charger in water or any other liquid.

Storage Recommendations

- The best storage place is one that is cool and dry, away from direct sunlight and excess heat or cold.

ENGLISH

- For long storage, it is recommended to store a fully charged battery pack in a cool dry place out of the charger for optimal results.

NOTE: Battery packs should not be stored completely depleted of charge. The battery pack will need to be recharged before use.

SAVE THESE INSTRUCTIONS FOR FUTURE USE

COMPONENTS (FIG. A)

WARNING: Never modify the power tool or any part of it. Damage or personal injury could result.

Refer to Figure A at the beginning of this manual for a complete list of components.

INTENDED USE

This drain snake is designed for professional drain cleaning applications.

DO NOT use under excessively wet conditions or in presence of flammable liquids or gases.

This drain snake is a professional power tool. **DO NOT** let children come into contact with the tool. Supervision is required when inexperienced operators use this tool.

Variable Speed Trigger Switch (Fig. A)

To turn the tool on, squeeze the trigger switch 2. To turn the tool off, release the trigger switch. The tool speed is controlled by varying the trigger position.

NOTE: Continuous use in variable speed range is not recommended. It may damage the switch and should be avoided.

Forward/Reverse Control Button (Fig. A)

A forward/reverse control button 11 determines the spin direction of the cable and also serves as a lock-off button. To select forward rotation, release the trigger switch and depress the forward/reverse control button on the right side of the tool.

To select reverse, release the trigger switch and depress the forward/reverse control button on the left side of the tool.

The center position of the control button locks the tool in the off position. When changing the position of the control button, be sure the trigger is released.

NOTE: The first time the tool is run after changing the direction of rotation, you may hear a click on start up. This is normal and does not indicate a problem.

NOTE: The tool must come to a complete stop before changing the tool's direction or running the tool in the opposite direction.

Front Handle/Cable Lock (Fig. A)

The front handle 10 has a lock position and unlock position. When pulled forward, the front handle will unlock allowing the cable to be pulled out of or pushed into the drum. When pulled backward, the front handle locks the cable into position.

Adjustable LED Worklight (Fig. A, D)

The adjustable LED worklight 7 (Fig. A) is located on the base of the fixed drum shield 8. The worklight switch 4 is located on the foot of the tool's main handle 3. The worklight is activated when the trigger switch is depressed. The low, medium and spotlight modes can be changed by moving the switch 4. If the trigger switch remains depressed, the worklight will remain on in all modes.

In low and medium settings, the beam will automatically turn off 20 seconds after the trigger switch is released.

Fig. D

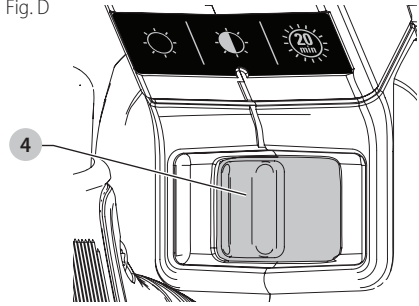

Spotlight Mode

The high setting is the spotlight mode. The spotlight will run for 20 minutes after the trigger switch is released. Two minutes before the spotlight will shut off, it will flash twice and then dim. To avoid the spotlight shutting off, lightly tap the trigger switch.

WARNING: While using the worklight in medium or spotlight mode, do not stare at the light or place the tool in a position which may cause anyone to stare into the light. Serious eye injury could result.

CAUTION: When using the tool as a spotlight, be sure it is secured on a stable surface where it will not cause a tripping or falling hazard.

CAUTION: Fully retract the cable into the drum before using the tool as a spotlight. Personal injury or property damage could result.

Low Battery Warning

When in spotlight mode and the battery is nearing complete discharge, the spotlight will flash twice and then dim. After two minutes, the battery will be completely discharged and the tool will immediately shut down. At this point, replace with a fresh battery.

WARNING: To reduce the risk of injury, always have a back-up battery or secondary lighting available if the situation warrants it.

ASSEMBLY AND ADJUSTMENTS

WARNING: To reduce the risk of serious personal injury, turn unit off and remove the battery pack before making any adjustments or removing/installing attachments or accessories. An accidental start-up can cause injury.

Cable Removal from the Drain Snake and Cable Drum Installation

! WARNING: To reduce the risk of injury, wear safety goggles or glasses with side shields. Always wear leather gloves with latex gloves inside. The cable is under stress and can unwind unexpectedly. Cable end feature may be sharp.

Remove the cable for cleaning after each use.

To remove the cable:

1. Remove the battery pack from the tool.
2. Pull the front handle **10** out away from the tool to the unlocked position.
3. With the tool supported vertically, remove the four screws from the drum cover **9**.

! WARNING: The cable is under stress and can uncoil unexpectedly. Keep pressure on the drum cover so it does not uncoil.

4. Carefully lift the drum cover up, reach underneath to hold the cable firmly while pulling off the drum cover **9** and front handle **10** to expose the inner drum **12**.
5. Remove the cable from the drum cover and front handle and tuck it into the inner drum. Set the drum cover aside.
6. Carefully remove the inner drum with cable from the drain snake.
7. When cleaning the cable, carefully uncoil the cable from the inner drum. Refer to **Cleaning** under **Maintenance**.

To install the cable:

1. Remove the battery pack from the tool.
2. Pull the front handle **10** out away from the tool to the unlocked position.
3. Remove the four screws from the drum cover **9**.
4. Fully wind the clean, dry cable into the inner drum **12** following the cable direction symbol **14** (Fig. A).

! WARNING: Winding the cable in the wrong direction could cause the tool to apply excessive torque causing the cable to kink during bind up.

! WARNING: Never install a new cable by threading it through the front handle on the tool. Always disassemble the drum cover so you can be sure the cable is wound in the proper direction.

5. Place the inner drum with cable back into the tool.
6. Carefully pull the cable bulb end **13** out of the inner drum and feed it through the front handle.

! WARNING: The cable is under stress and can unwind unexpectedly. Keep pressure on the cable so it does not unwind.

7. Place the drum cover and front handle over the inner drum and reinstall the four screws. Tighten securely.

NOTE: If the unit is unbalanced and/or vibrates unnecessarily, the cable may be wound poorly.

OPERATION

! WARNING: To reduce the risk of serious personal injury, turn unit off and remove the battery pack before making any adjustments or removing/installing attachments or accessories. An accidental start-up can cause injury.

! WARNING: Always wear eye and other protective equipment appropriate to the task.

! WARNING: Always wear leather work gloves with latex gloves inside.

! WARNING: Do not operate if more than 6" (15 cm) of cable is outside of pipe or drum.

! WARNING: The cable can whip or tangle.

! WARNING: Do not hold cable while it is turning.

! WARNING: Cable end feature may be sharp.

Installing and Removing the Battery Pack (Fig. D)

NOTE: For best results, make sure your battery pack is fully charged.

To install the battery pack **5** into the tool handle, align the battery pack with the rails inside the tool's handle and slide it into the handle until the battery pack is firmly seated in the tool and ensure that it does not disengage.

To remove the battery pack from the tool, press the release button **6** and firmly pull the battery pack out of the tool handle. Insert it into the charger as described in the charger section of this manual.

Fig. D

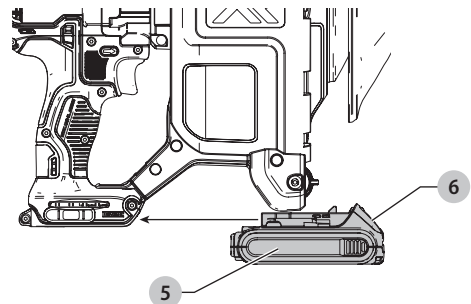

Proper Hand Position (Fig. E)

! WARNING: To reduce the risk of serious personal injury, ALWAYS use proper hand position as shown.

! WARNING: To reduce the risk of serious personal injury, ALWAYS hold securely in anticipation of a sudden reaction.

Proper hand position requires one hand on the main handle **3** and one hand on the front handle grip **10**.

ENGLISH

Fig. E

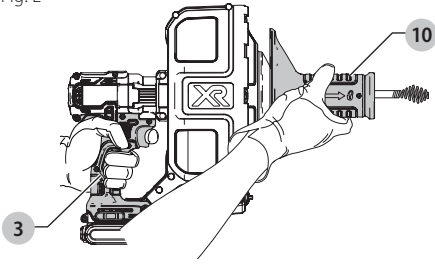

Clearing a Drain

1. Put forward/reverse control button ① in the center position.
2. Install the battery pack into the handle.
3. Move the forward/reverse control button ① to the forward position.
4. Pull the front handle ⑩ out into the unlock position.
5. Pull at least 18" (46 cm) of the cable from the tool. Insert at least 12" (30 cm) of cable into the drain, leaving no more than 6" (15 cm) of the cable exposed.

WARNING: Do not operate if more than 6" (15 cm) of cable is exposed. Greater distance can cause twisting, kinking, breaking or whipping of the cable.

WARNING: Always wear leather work gloves with latex gloves inside when operating the drain snake.

WARNING: If the cable is stopped either by the blockage or the pipe so that the cable will not rotate, refer to the **To Unbind Drain Snake** section.

WARNING: If the cable is stopped from rotating due to a blockage or the pipe, release the trigger immediately.

WARNING: Only operate in reverse to remove the cable from an obstruction.

6. Continue to feed the cable out by hand into the pipe until it becomes difficult.
7. As feeding the cable becomes more difficult, move the front handle back to lock the cable with only 6" (15 cm) of cable exposed. With hands clear of the cable, pull the trigger to begin rotating the cable, and move the drain snake towards the drain opening to push the cable down the drain.
8. Release the trigger, move the front handle forward to unlock the cable, grip the cable with your gloved hand to prevent it from pulling out of the drain and pull the drain snake back so that no more than 6" (15 cm) of cable is exposed.

NOTE: The cable is not attached to the inner drum. Use care when feeding out the last 5 to 7 feet (1.5 m to 2.13 m) of the cable, to ensure that it does not come out of the machine.

9. Repeat the steps 6–8 to continue advancing the cable.

To Unbind Drain Snake

WARNING: Be sure the cable has come to a complete stop before setting to reverse position.

1. Set the front handle to the locked position and the forward/reverse switch to the reverse position.
2. Withdraw the tool a few inches while running slowly in reverse to free cable.
3. Stop the tool.
4. After the tool has come to a complete stop, switch back to the forward position.

CAUTION: Running the tool in reverse for extended periods can cause damage to the cable and accessories. Only operate in reverse to remove the cable from an obstruction.

Removing Cable From Drain

1. Set the front handle to the locked position.
2. Set the forward/reverse switch to the forward position.
3. Pull the trigger slightly and pull the tool back to remove about 6" (15 cm) of cable from the drain.
4. Release the trigger and lock the forward/reverse button in the center position.
5. Wipe the exposed cable with a rag, unlock the front handle and feed it back into the tool.
6. Repeat steps 1–5 until the cable is near the drain opening. Then feed the remaining cable back into the drum by hand.

WARNING: Never retract the cable bulb end from the drain opening while the cable is rotating. The cable could whip and cause serious injury.

NOTE: Before storing the tool, wash the cable and drum (refer to **Cleaning**).

HINT: It's useful to have a stream of water running through the line to wash fragments away while the machine is in operation and after. Avoid getting the motor, handle and battery wet.

Cable Application Chart

Cable Size	Pipe Size	Typical Applications
1/4" (6.35 mm)	3/4" to 1-1/2" (19 mm to 38 mm)	Sinks and bathtub drains
5/16" (8 mm)	1-1/4" to 2" (32 mm to 50 mm)	Sinks, wash tubs, small drains
3/8" (9.5 mm)	2" to 3" (50 mm to 76 mm)	Floor drains, stacks, toilets

The 1/4" (6.35 mm) and 5/16" (8 mm) diameter cables with a bulb end can be rotated through most strainer crossbars and work well in lines blocked by soft stoppages such as hair, soap, fats, etc.

Maximum Capacity: 50 ft. (15.2 m) of 1/4" (6.35 mm) and 5/16" (8 mm) cable and 35 ft. (10.7 m) of 3/8" (9.5 mm) cable.

MAINTENANCE

WARNING: To reduce the risk of serious personal injury, turn unit off and remove the battery pack before making any adjustments or removing/installing attachments or accessories. An accidental start-up can cause injury.

Cleaning

 **WARNING:** Remove battery before cleaning tool.

 **WARNING:** Blow dirt and dust out of all air vents with clean, dry air at least once a week. To minimize the risk of eye injury, always wear ANSI Z87.1 approved eye protection when performing this.

 **WARNING:** Never use solvents or other harsh chemicals for cleaning the non-metallic parts of the tool. These chemicals may weaken the plastic materials used in these parts. Use a cloth dampened only with water and mild soap. Never let any liquid get inside motor and handle of the tool; never immerse any part of the tool into a liquid.

Rinse, dry and lightly oil the cable after each use to prevent damage from sediment and drain cleaning chemicals. Remove the cable and inner drum before rinsing. Refer to **Cable Removal from the Drain Snake and Cable Drum Installation**.

NOTE: The cable can twist, kink or break if overstressed.

 **WARNING:** Wear leather gloves with latex gloves inside.

Accessories

 **WARNING:** Since accessories, other than those offered or recommended by DeWALT, have not been tested with this product, use of such accessories with this tool could be hazardous. To reduce the risk of injury, only DeWALT recommended accessories should be used with this product.

Recommended accessories for use with your tool are available at extra cost from your local dealer or authorized service center. If you need assistance in locating any accessory, please contact DeWALT Industrial Tool Co., 701 East Joppa Road, Towson, MD 21286, call 1-800-4-DeWALT (1-800-433-9258) or visit our website: www.dewalt.com.

DeWALT Accessories Available for Purchase

DCD2000	Inner Drum
DCD2005	25' (7.6 m) 5/16" (8 mm) Bulb Head Cable

Repairs

The charger and battery pack are not serviceable.

 **WARNING:** To assure product SAFETY and RELIABILITY, repairs, maintenance and adjustment (including brush inspection and replacement, when applicable) should be performed by a DeWALT factory service center or a DeWALT authorized service center. Always use identical replacement parts.

Register Online

Thank you for your purchase. Register your product now for:

- **WARRANTY SERVICE:** Registering your product will help you obtain more efficient warranty service in case there is a problem with your product.

- **CONFIRMATION OF OWNERSHIP:** In case of an insurance loss, such as fire, flood or theft, your registration of ownership will serve as your proof of purchase.
- **FOR YOUR SAFETY:** Registering your product will allow us to contact you in the unlikely event a safety notification is required under the Federal Consumer Safety Act.

Register online at www.dewalt.com/register.

Three Year Limited Warranty

DeWALT will repair, without charge, any defects due to faulty materials or workmanship for three years from the date of purchase. This warranty does not cover part failure due to normal wear or tool abuse. For further detail of warranty coverage and warranty repair information, visit www.dewalt.com or call 1-800-4-DeWALT (1-800-433-9258). This warranty does not apply to accessories or damage caused where repairs have been made or attempted by others. THIS LIMITED WARRANTY IS GIVEN IN LIEU OF ALL OTHERS, INCLUDING THE IMPLIED WARRANTY OF MERCHANTABILITY AND FITNESS FOR A PARTICULAR PURPOSE, AND EXCLUDES ALL INCIDENTAL OR CONSEQUENTIAL DAMAGES. Some states do not allow limitations on how long an implied warranty lasts or the exclusion or limitation of incidental or consequential damages, so these limitations may not apply to you. This warranty gives you specific legal rights and you may have other rights which vary in certain states or provinces.

In addition to the warranty, DeWALT tools are covered by our:

1 YEAR FREE SERVICE

DeWALT will maintain the tool and replace worn parts caused by normal use, for free, any time during the first year after purchase.

2 YEARS FREE SERVICE ON DEWALT BATTERY PACKS

DC9071, DC9091, DC9096, DC9182, DC9280, DC9360, DCB120, DCB127, DCB201, DCB203, DCB203BT, DCB207, DCB361

3 YEARS FREE SERVICE ON DEWALT BATTERY PACKS

DCB200, DCB204, DCB204BT, DCB205, DCB606

NOTE: Battery warranty voided if the battery pack is tampered with in any way. DeWALT is not responsible for any injury caused by tampering and may prosecute warranty fraud to the fullest extent permitted by law.

90 DAY MONEY BACK GUARANTEE





If you are not completely satisfied with the performance of your DeWALT Power Tool, Laser, or Nailer for any reason, you can return it within 90 days from the date of purchase with a receipt for a full refund – no questions asked.

LATIN AMERICA: This warranty does not apply to products sold in Latin America. For products sold in Latin America, see country specific warranty information contained in the packaging, call the local company or see website for warranty information.

FREE WARNING LABEL REPLACEMENT: If your warning labels become illegible or are missing, call 1-800-4-DeWALT (1-800-433-9258) for a free replacement.

Définitions : symboles et termes d'alarmes sécurité

Ces guides d'utilisation utilisent les symboles et termes d'alarmes sécurité suivants pour vous prévenir de situations dangereuses et de risques de dommages corporels ou matériels.

-  **DANGER** : indique une situation dangereuse imminente qui, si elle n'est pas évitée, **entraînera la mort ou des blessures graves**.
-  **AVERTISSEMENT** : indique une situation potentiellement dangereuse qui, si elle n'est pas évitée, **pourrait entraîner la mort ou des blessures graves**.
-  **ATTENTION** : indique une situation potentiellement dangereuse qui, si elle n'est pas évitée, **pourrait entraîner des blessures légères ou modérées**.
-  (Si utilisé sans aucun terme) Indique un message propre à la sécurité.

AVIS : indique une pratique ne posant **aucun risque de dommages corporels** mais qui par contre, si rien n'est fait pour l'éviter, **pourrait poser des risques de dommages matériels**.

Fig. A

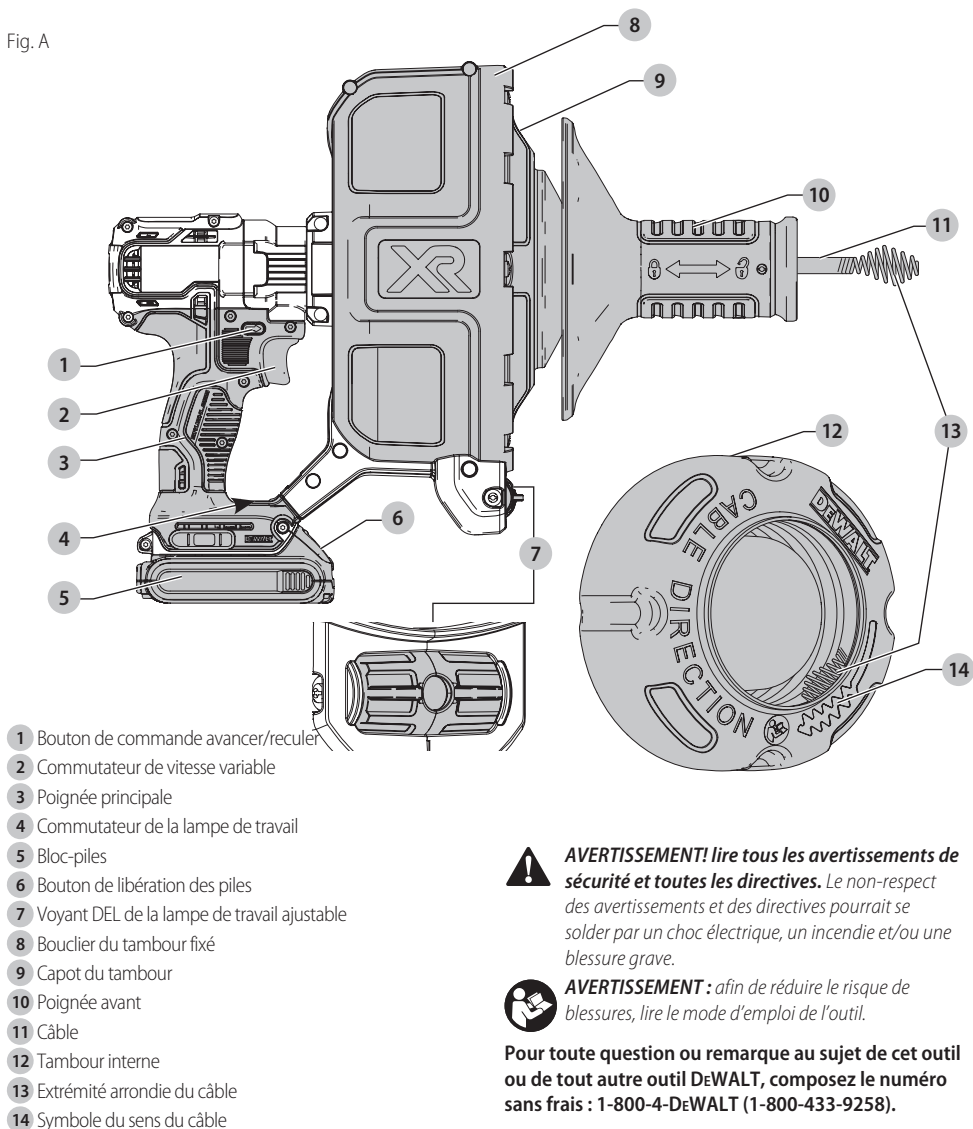

- 1 Bouton de commande avancer/reculer
- 2 Commutateur de vitesse variable
- 3 Poignée principale
- 4 Commutateur de la lampe de travail
- 5 Bloc-piles
- 6 Bouton de libération des piles
- 7 Voyant DEL de la lampe de travail ajustable
- 8 Bouclier du tambour fixé
- 9 Capot du tambour
- 10 Poignée avant
- 11 Câble
- 12 Tambour interne
- 13 Extrémité arrondie du câble
- 14 Symbole du sens du câble

 **AVERTISSEMENT!** lire tous les avertissements de sécurité et toutes les directives. Le non-respect des avertissements et des directives pourrait se solder par un choc électrique, un incendie et/ou une blessure grave.

 **AVERTISSEMENT** : afin de réduire le risque de blessures, lire le mode d'emploi de l'outil.

Pour toute question ou remarque au sujet de cet outil ou de tout autre outil DeWALT, composez le numéro sans frais : 1-800-4-DeWALT (1-800-433-9258).