



Installation Support • Soporte de instalación • Support d'installation

**Personal Assistance, Product Specs, & "How-to" Questions:**

Asistencia personal, especificaciones del producto y preguntas sobre "cómo hacerlo":

Aide personnelle, spécifications du produit et questions « pratico-pratiques » :

**1-800-PFAUCET (732-8238)**

**[pfisterfaucets.com/support](http://pfisterfaucets.com/support)**

Installation Videos Available  
Videos de instalación a disposición  
Vidéos d'installation disponibles



[pfisterfaucets.com/videos](http://pfisterfaucets.com/videos)

**▲ WARNING / AVERTENCIA / AVERTISSEMENT**

To reduce the risk of injury or property damage, read all instructions before installing product. Wear safety goggles. Product must be installed in accordance with all state & local plumbing & building codes. Call a professional if you are uncertain about installing this product.

Para disminuir el riesgo de lesiones o daños a la propiedad, lea todas las instrucciones antes de instalar el producto. Utilice gafas de seguridad. El producto deberá instalarse de acuerdo con la normativa de plomería y construcción estatal y local. Llame a un profesional si no está seguro sobre cómo instalar este producto.

Pour réduire le risque de blessures ou de dommages, lisez toutes les instructions avant d'installer l'appareil. Porter des lunettes de sécurité. Il faut installer l'appareil en respectant tous les codes de construction et de plomberie locaux et d'État. Appelez un professionnel si vous n'êtes pas certain de la façon d'installer cet appareil.

**Required Tools  
Herramientas necesarias  
Outils nécessaires**



Plumber's Putty  
Masilla para plomería  
Mastic de plombier



Adjustable Wrench  
Llave ajustable  
Clé réglable



Safety Goggles  
Anteojos de seguridad  
Lunettes de sûreté

**Additional Helpful Tools  
Otras herramientas útiles  
Outils supplémentaires utiles**

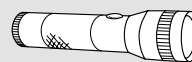

Flashlight  
Linterna  
Lampe De Poche

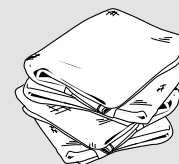

Cloth  
Paño de limpieza  
Chiffon

**Parts in the Box • Piezas en la caja • Pièces dans la boîte**

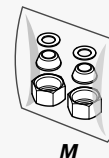
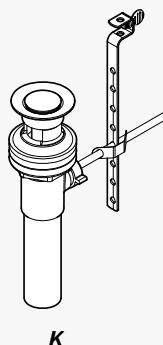
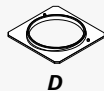
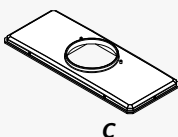
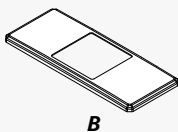
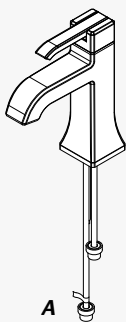

Aerator Tool  
Herramienta para el aireador  
Outil d'aérateur

**1 Turn Off Water Supply • Cierre el suministro de agua • Couper l'alimentation en eau**



Locate water supply inlets and shut off the water supply valves. These are usually found under the sink or near the water meter. If you are replacing an existing faucet, remove the old faucet from the sink and clean the sink surface thoroughly.

Ubique las entradas del suministro de agua y cierre las válvulas de suministro de agua. Generalmente se encuentran debajo del fregadero o cerca del medidor de agua. Si se trata de un reemplazo de grifo, quite el grifo viejo y limpie completamente la superficie del fregadero.

Repérer les arrivées d'eau et fermer leurs robinets. Ces robinets se trouvent généralement sous le lavabo ou à côté du compteur d'eau. En cas de remplacement d'un robinet existant, le déposer du lavabo et nettoyer soigneusement la surface de ce dernier.

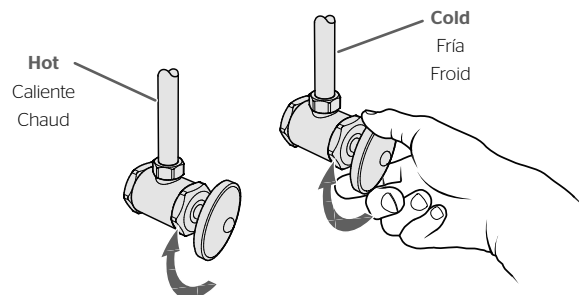

**2** **OPTION 1: Install Faucet *without Deckplate***  
**OPCIÓN 1: Instale el grifo sin la placa de cubierta**  
**OPTION 1: Installer le robinet sans le plate-forme**

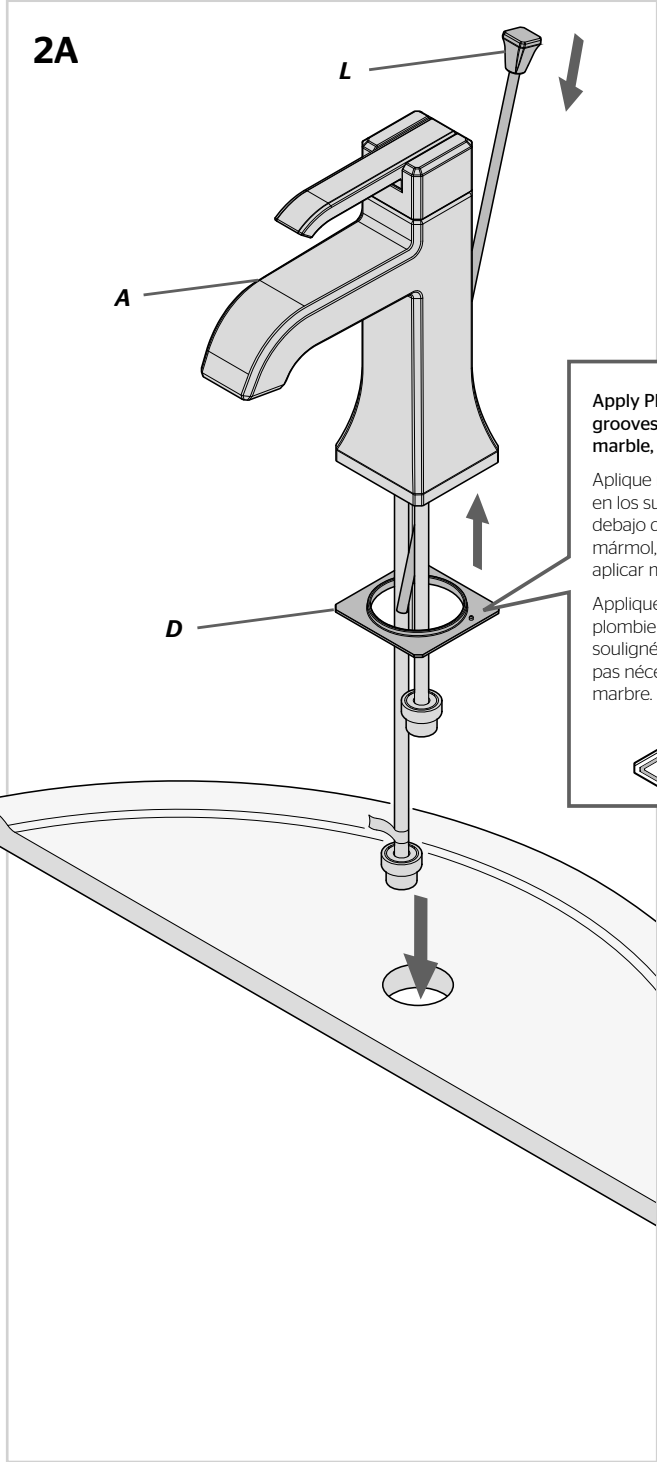
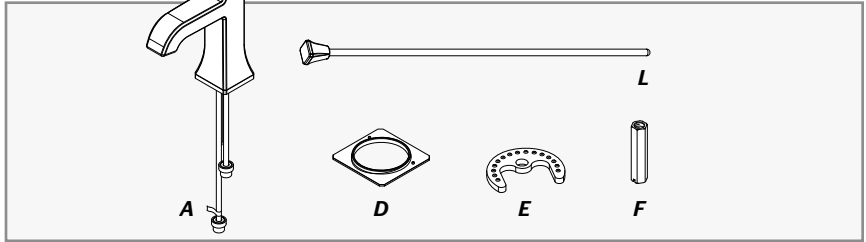
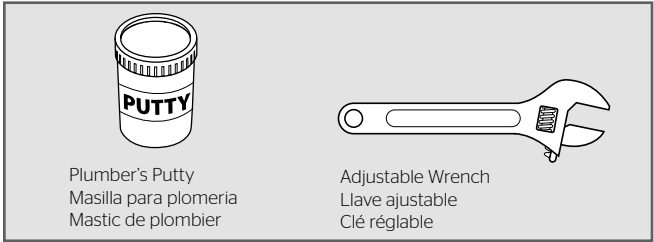
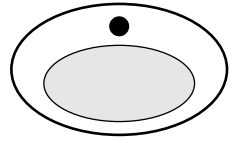

**Apply Plumber's Putty in highlighted grooves beneath D. If installing on marble, no putty needed.**

Aplique masilla de plomero en los surcos destacados debajo de D. Si instala en mármol, no es necesario aplicar masilla.

Appliquez le mastic de plombier dans les rainures soulignées sous D. Le mastic n'est pas nécessaire si vous installez sur du marbre.



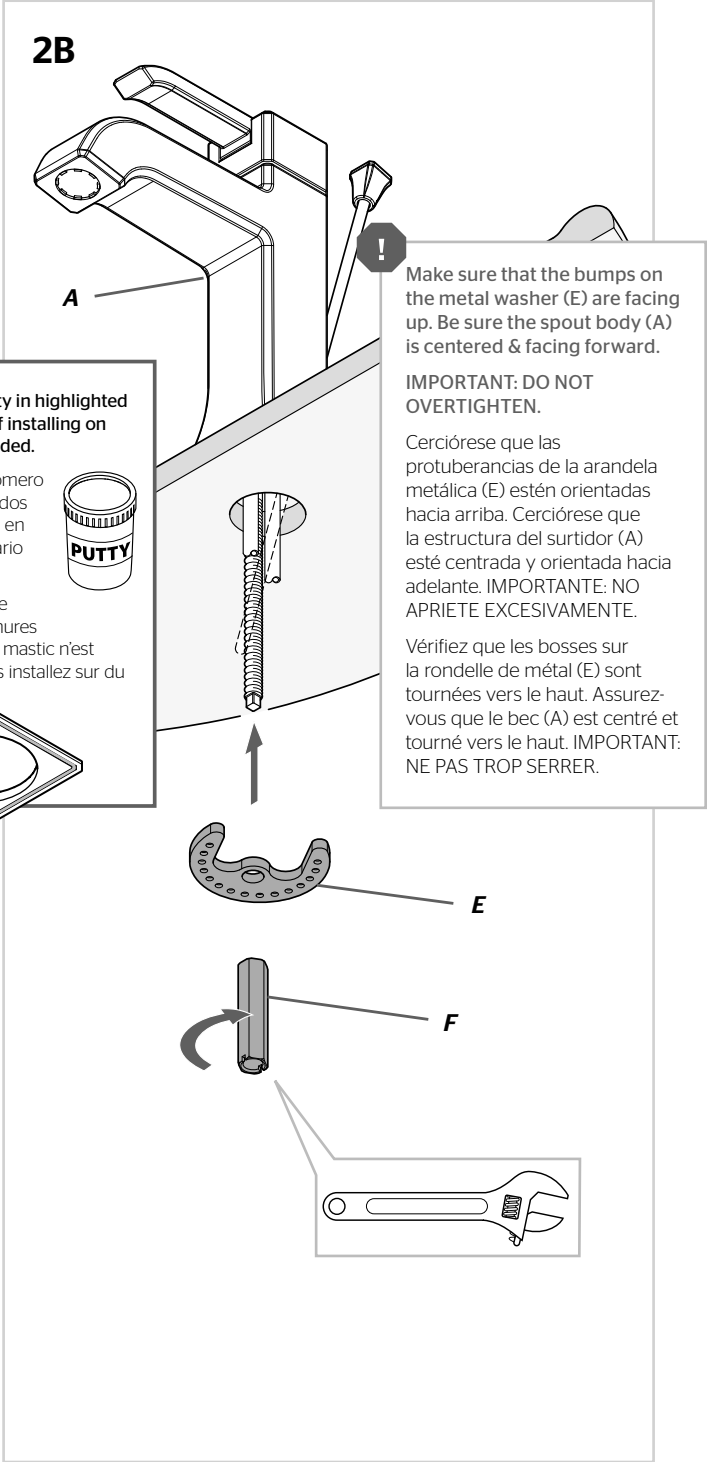

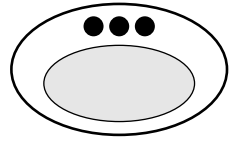

**2** **OPTION 2: Install Faucet *with Deckplate***  
**OPCIÓN 2: Instale el grifo con la placa de cubierta**  
**OPTION 2: Installer le robinet avec le plate-forme**



Plumber's Putty  
 Masilla para plomería  
 Mastic de plombier

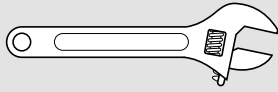

Adjustable Wrench  
 Llave ajustable  
 Clé réglable

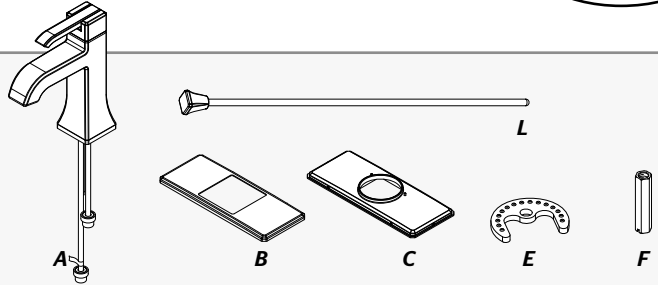

**2A**

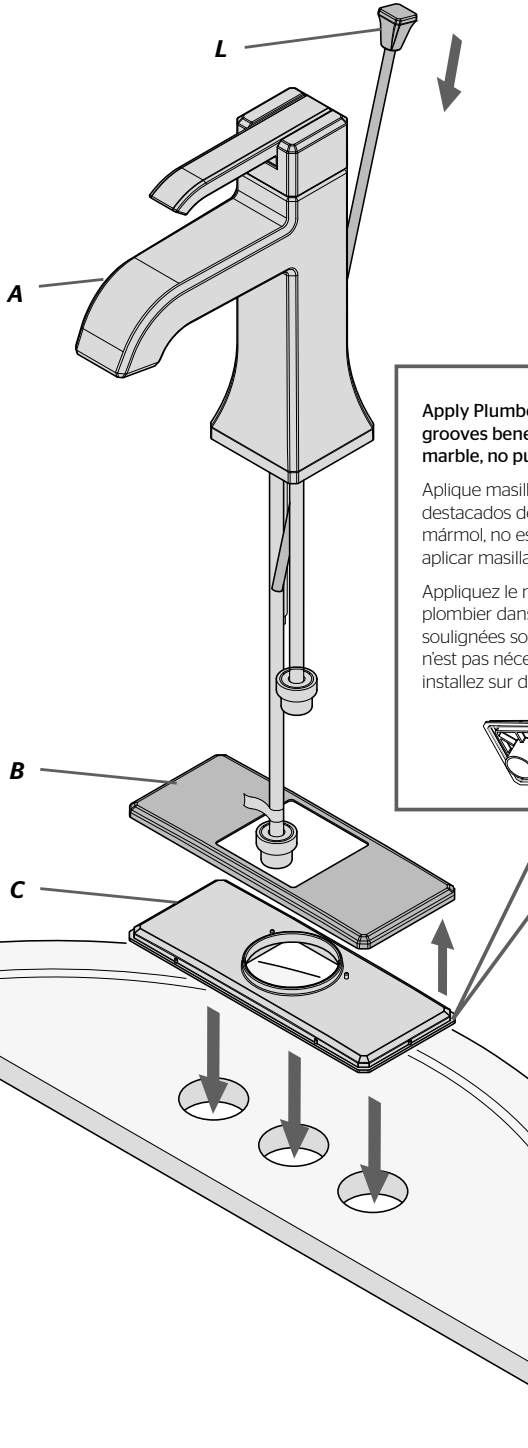

**Apply Plumber's Putty in highlighted grooves beneath C. If installing on marble, no putty needed.**

Aplique masilla de plomero en los surcos destacados debajo de C. Si instala en mármol, no es necesario aplicar masilla.

Appliquez le mastic de plombier dans les rainures soulignées sous C. Le mastic n'est pas nécessaire si vous installez sur du marbre.

**2B**

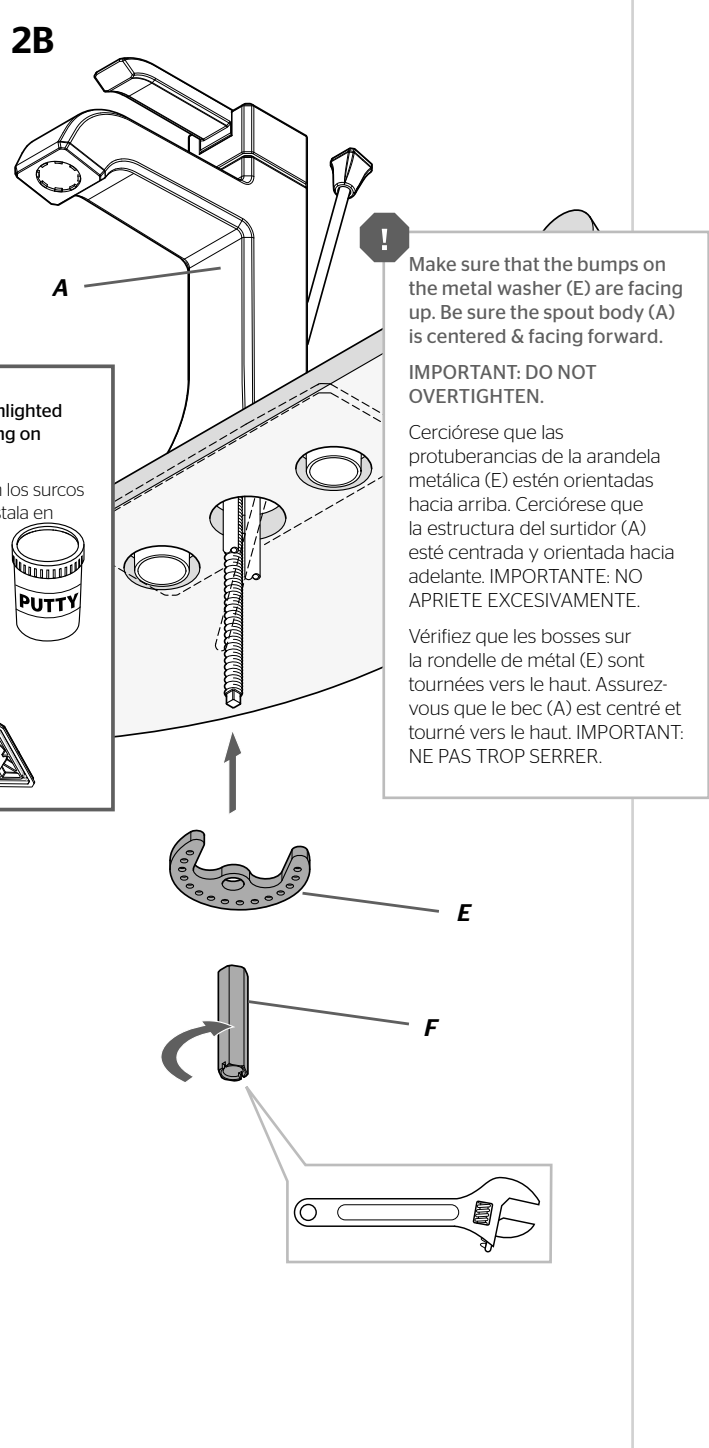

**!** Make sure that the bumps on the metal washer (E) are facing up. Be sure the spout body (A) is centered & facing forward.

**IMPORTANT: DO NOT OVERTIGHTEN.**

Cerciórese que las protuberancias de la arandela metálica (E) estén orientadas hacia arriba. Cerciórese que la estructura del surtidor (A) esté centrada y orientada hacia adelante. **IMPORTANTE: NO APRIETE EXCESIVAMENTE.**

Vérifiez que les bosses sur la rondelle de métal (E) sont tournées vers le haut. Assurez-vous que le bec (A) est centré et tourné vers le haut. **IMPORTANT: NE PAS TROP SERRER.**

### 3 Connect Water Supply Lines

Conecte las tuberías de suministro de agua

Raccorder les conduites d'alimentation en eau

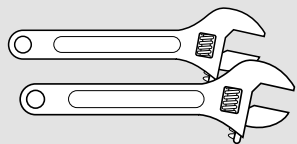

Adjustable Wrench (x2)  
Llave ajustable (x2)  
Clé réglable (x2)



G (x2)



H (x2)

3A

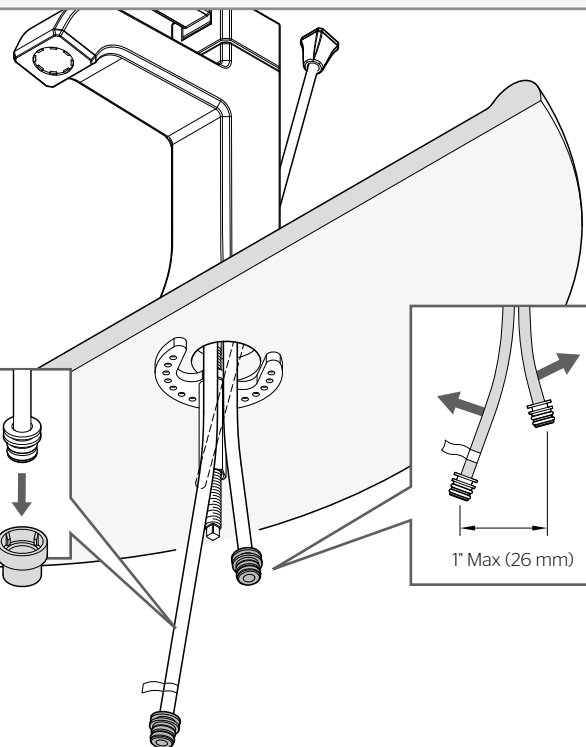

x2

Remove protective caps.

Retire la cubiertas protectoras.

Enlevez le capuchons protecteurs.

1" Max (26 mm)



**Water Supply Lines not included.** Please consult manufacturer and/or its instructions for the correct method of installation of supply lines & fittings.

**IMPORTANT:** Incorrect application of supply lines and fittings may result in the failure or leak of the supply lines and fitting.

**Las tuberías de suministro de agua no están incluidas.** Consulte por favor el fabricante y/o sus instrucciones para el método correcto de instalación de líneas de suministro y de guarniciones.

**PRECAUCIÓN:** El uso incorrecto de líneas de suministro y de guarniciones puede dar lugar a la falta o al escape de las líneas de suministro y de la guarnición.

**Les tuyaux d'arrivée d'eau ne sont pas fournis.** Veuillez consulter le fabricant et/ou ses instructions pour la méthode correcte d'installation des canalisations et des garnitures d'alimentation.

**ATTENTION:** L'application incorrecte des canalisations et des garnitures d'alimentation peut avoir comme conséquence l'échec ou la fuite des canalisations et de l'ajustage de précision d'alimentation.

3B

x2

Hot & Cold  
Caliente y fría  
Chaud et froid

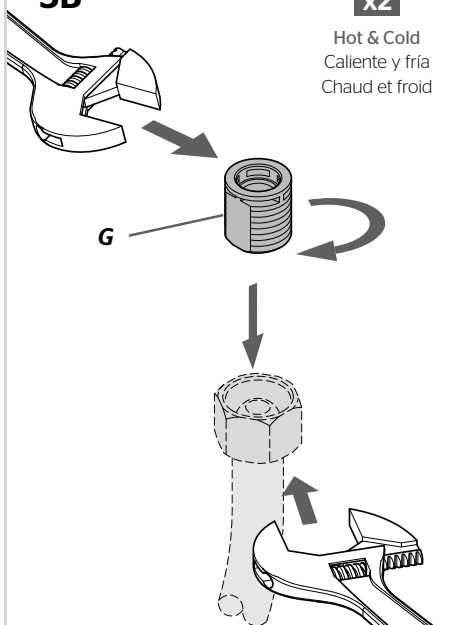

G

3C

Hot  
Caliente  
Chaud

Cold  
Fría  
Froid

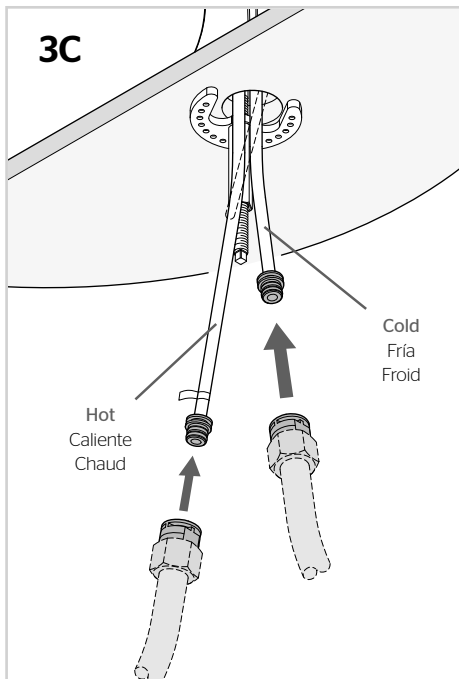

3D

x2

Hot & Cold  
Caliente y fría  
Chaud et froid

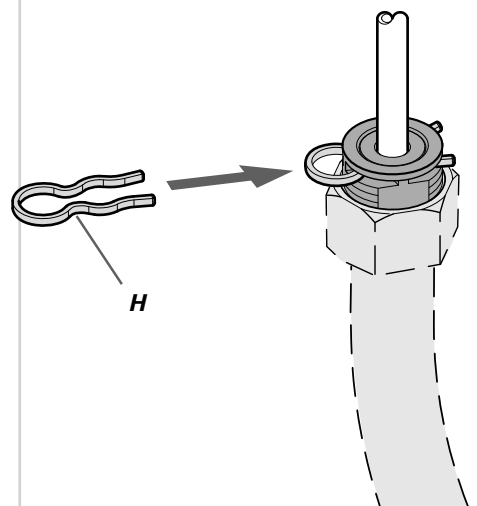

H

# 4

## Prepare & Install Pop-Up

Prepare e instale el tapón retráctil

Préparez & installez le bouchon à clapet

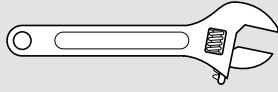

Adjustable Wrench  
Llave ajustable  
Clé réglable

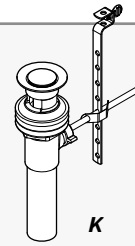

### 4A

#### Disassemble Pop-up Assembly

Desensamble el ensamble del tapón retráctil

Démontez l'ensemble bouchon à clapet

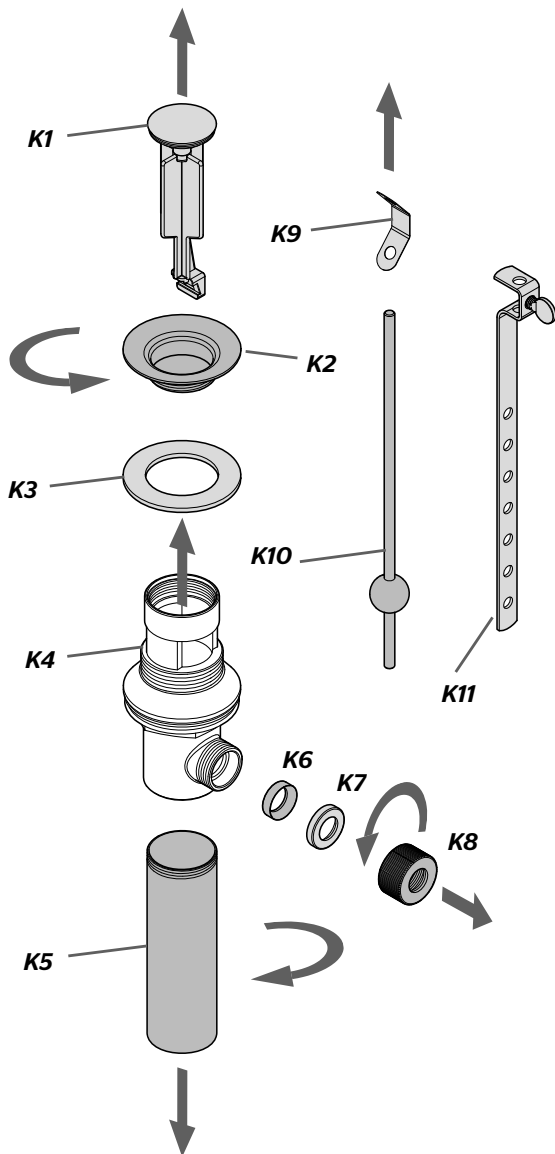

### 4B

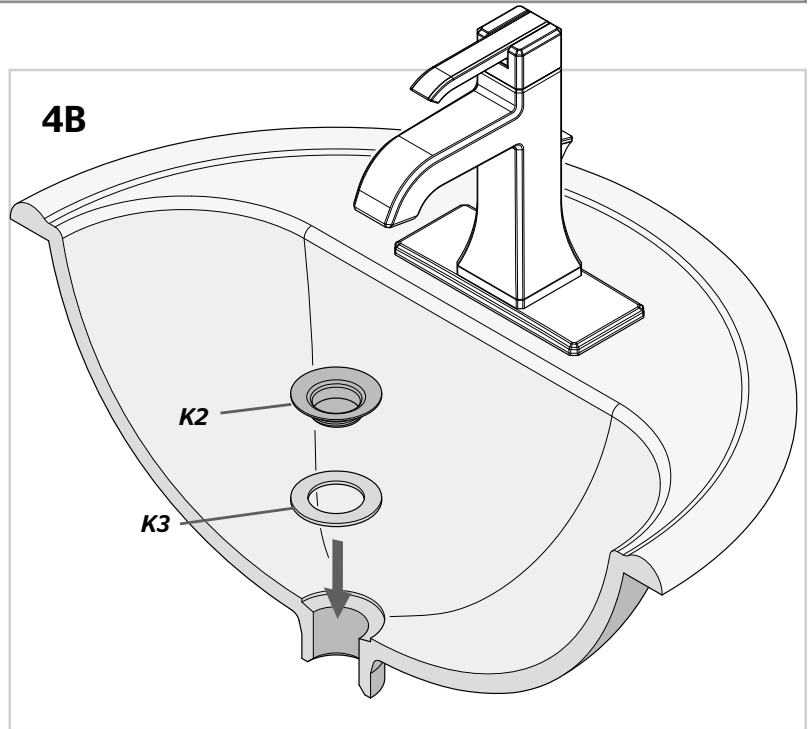

### 4C

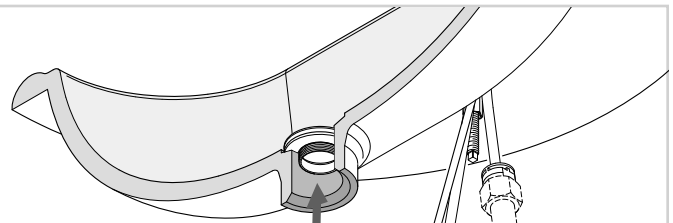

Thread Drain Body (K4) to bottom of Flange (K2) and adjust so that Ball Rod opening faces rear.

Enrosque la estructura de desagüe (K4) a la parte inferior de la pestaña (K2) y ajuste de modo que la abertura de la varilla con glóbulo esté orientada hacia la parte posterior.

Vissez le corps du renvoi (K4) au bas de la bride (K2) et réglez de façon à ce que l'ouverture de la tige soit tournée vers l'arrière.

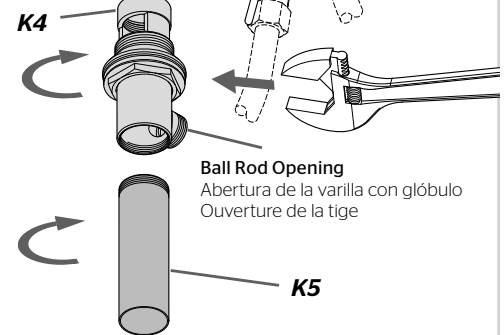

Ball Rod Opening  
Abertura de la varilla con glóbulo  
Ouverture de la tige

Connect to Drain  
Conexión al desagüe  
Branchez au renvoi

## 5 Prepare & Connect Lift Rod

Prepare y conecte la varilla de elevación

Préparez & connectez la tige levier

No Tools Required for This Step  
No se necesitan herramientas para este paso  
Aucun outil n'est nécessaire pour cette étape

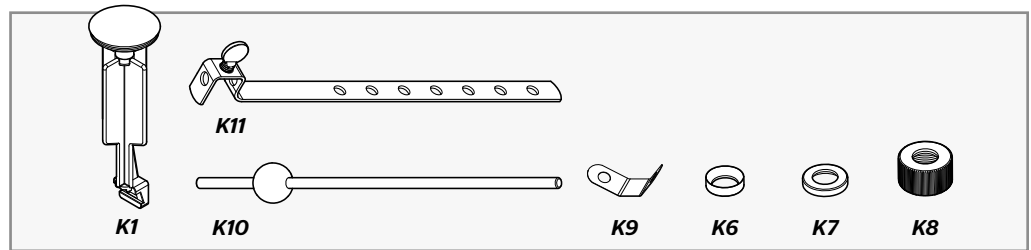

### 5A

Option 1  
Opción 1  
Option 1

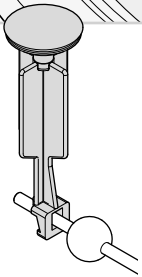

Option 2  
Opción 2  
Option 2

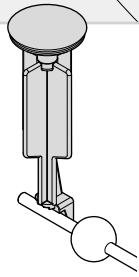

K1 can be installed in two ways: Fixed Position (Option 1) or a Removable Position (Option 2)

K1 puede instalarse de dos formas: posición fija (Opción 1) o posición removable (Opción 2).

On peut installer K1 de deux façons : Position fixe (Option 1) ou position amovible (Option 2).

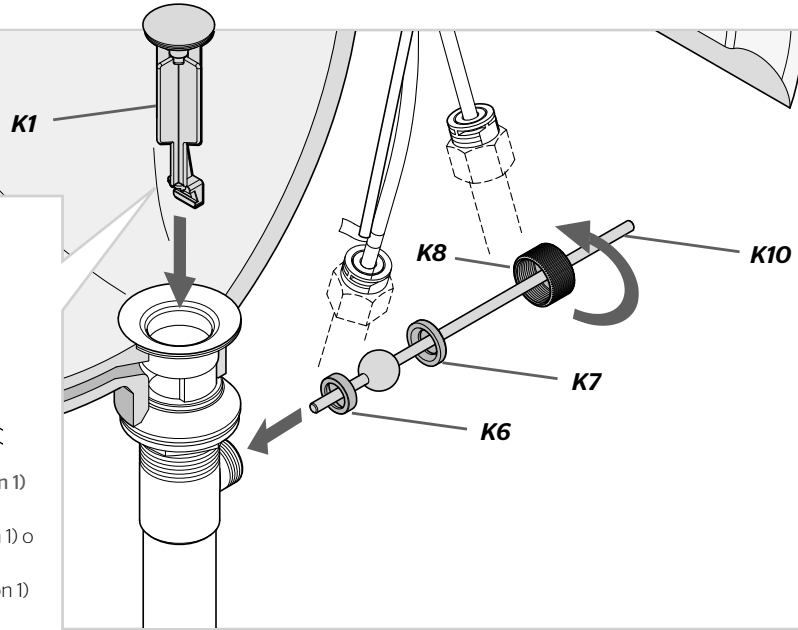

### 5B Assemble Lift Rod Connection

Ensamble de la conexión de varilla de elevación

Assemblez la connexion de la tige levier

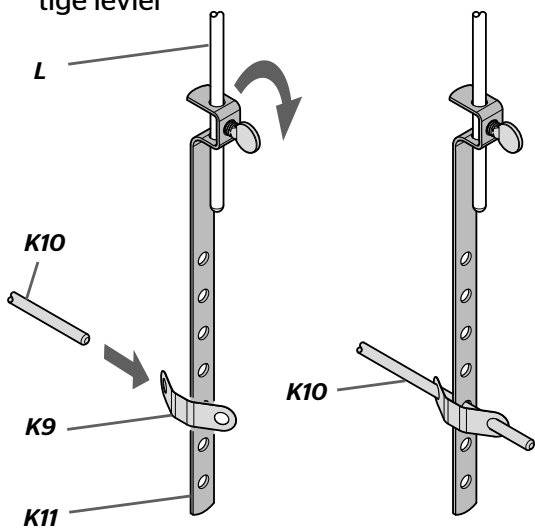

### 5C Pop-Up Completion

Terminer le bouchon à clapet

Finalización de la instalación del tapón retráctil

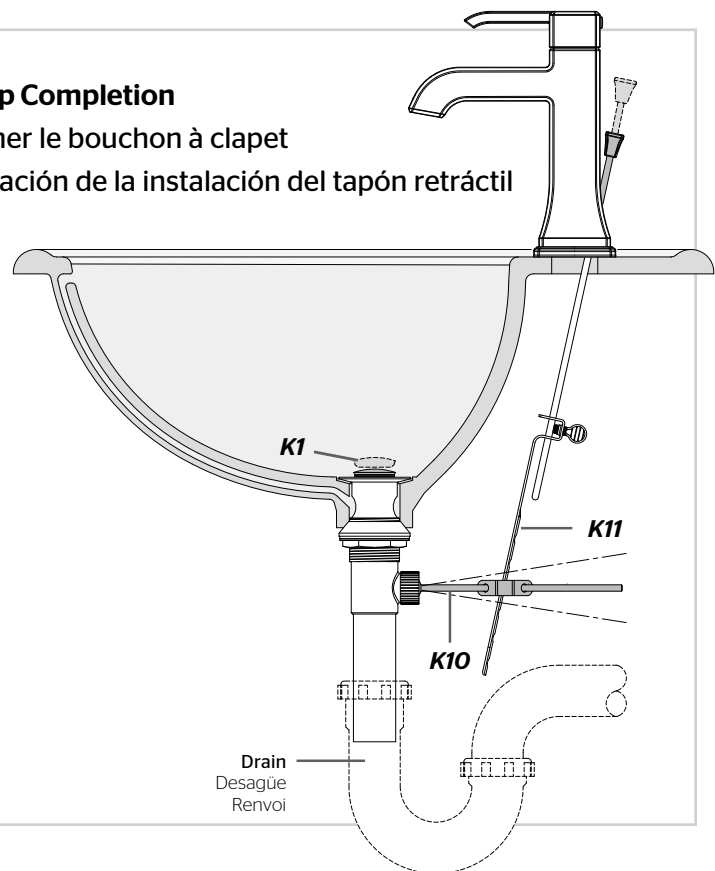

## 6 Turn On Water & Confirm Proper Installation

Active el suministro de agua y confirme que la instalación está adecuadamente efectuada

Ouvrez l'eau et confirmez que l'installation est adéquate

### 6A

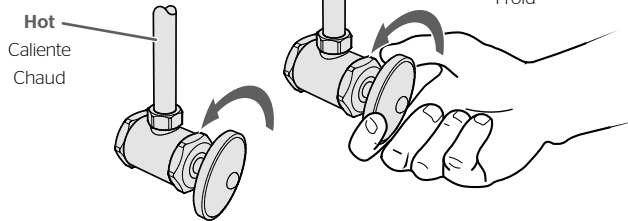

### Faucet Functions • Funciones del grifo • Fonctions du robinet

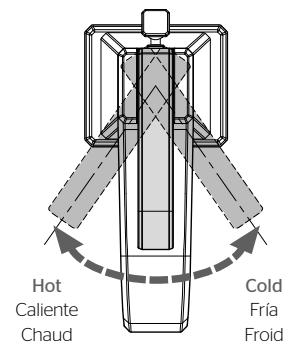
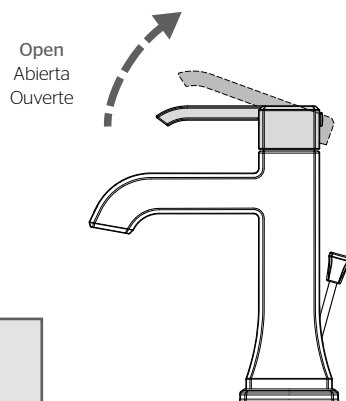

Check for leaks above and below the sink.

Revise si hay fugas encima y debajo del fregadero

Assurez-vous qu'il n'y a pas de fuite au dessus ou au dessous du lavabo

## 7 Flush the Faucet

Enjuague el grifo

Vidanger l'robinet

### 7A

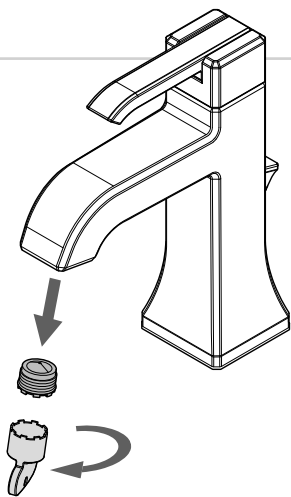

Use aerator tool to remove aerator.

Utilice la herramienta del aireador para retirarlo.

Utilisez l'outil d'aérateur pour enlever l'aérateur.

### 7B

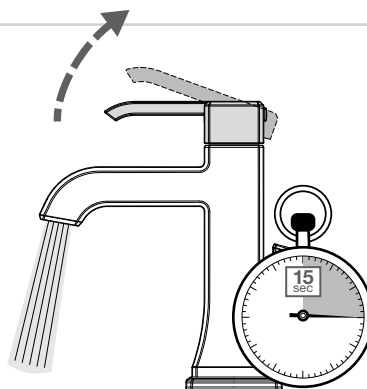

Allow hot & cold water to run for at least 15 seconds each.

Deje correr el agua caliente y fría durante al menos 15 segundos cada una.

Laissez couler de l'eau chaude et de l'eau froide pendant au moins 15 secondes chacune.

### 7C

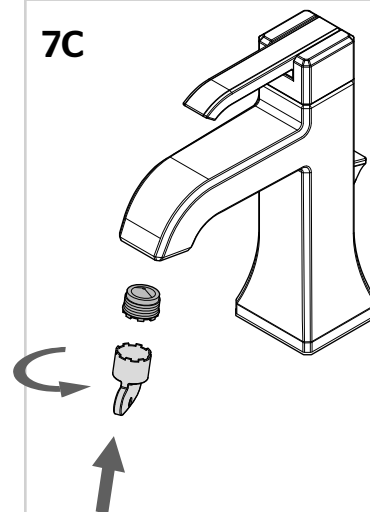

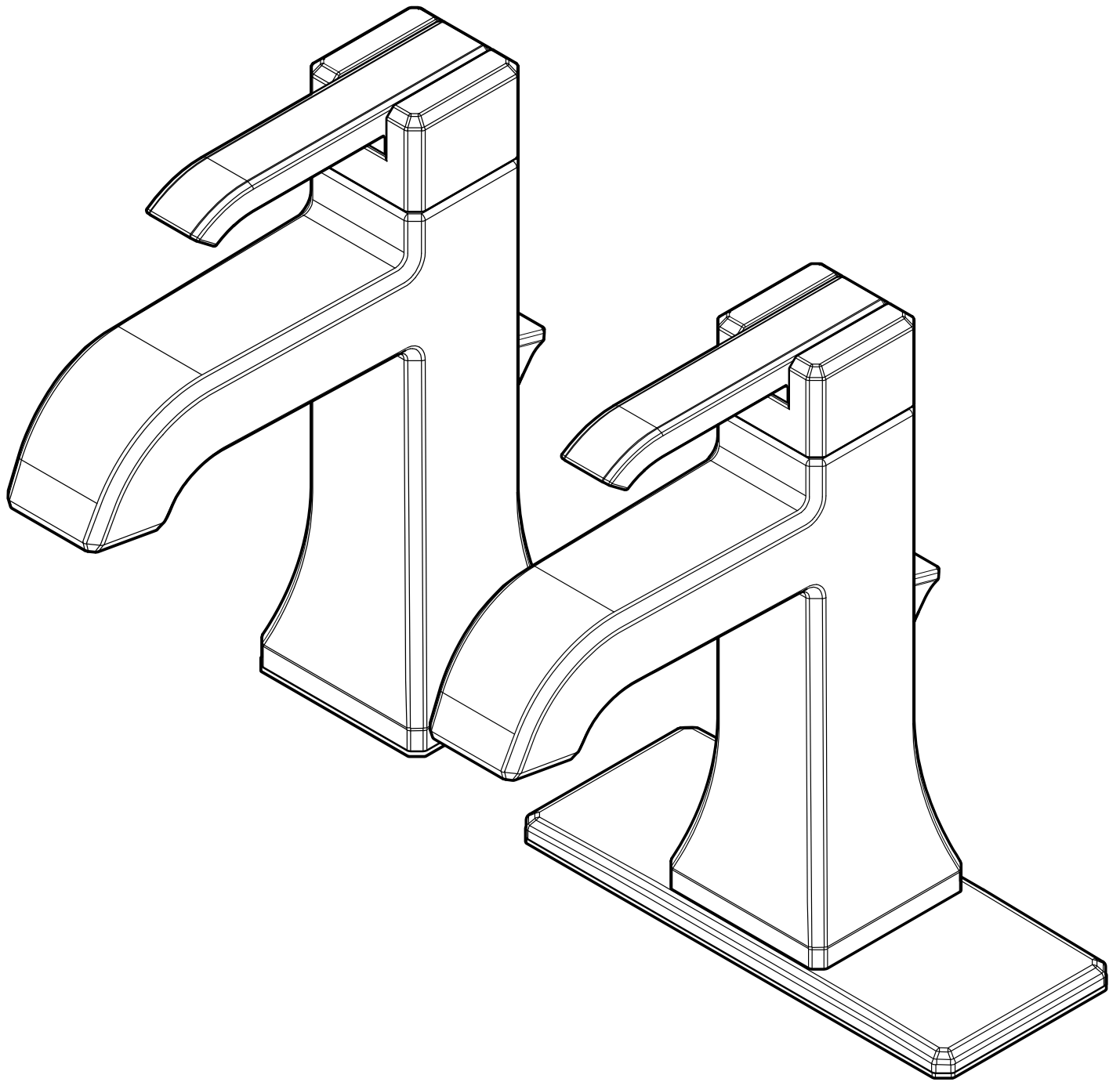

**For Additional Installation Help:**

Para la instalación adicionales de ayuda:

Pour aider à l'installation supplémentaires:

**Pfister**<sup>®</sup>

1-800-PFAUCET (732-8238)

[pfisterfaucets.com](http://pfisterfaucets.com)