

# LED Wrap Fixture

Models: 65-1081, 60-1082, 60-1083, 60-1084, 65-1091, 65-1092, 65-1095, 65-1096, 65-1097, 65-1098



## INSTALLATION AND SAFETY INSTRUCTIONS

**IMPORTANT: Read before installing fixture. Retain for future reference.**

**CAUTION:** Read the instruction carefully and save them. Failure to install and wire fixture or Install In accordance with the National Electrical Codes (NEC), all applicable Federal, State and Local electrical codes, as well as specific U.L. safety standards for the intended working environment (location/application), may cause serious personal injury, death and/or property damage. This product must be installed by a person familiar with the construction and operation of the product and the hazards involved.

**SAFETY INFORMATION**  
**100~277V 50/60Hz. FOR INDOOR OR DAMP LOCATION.**

**WARNING:** LED module are integrated to the fixture and are not removable or replaceable. Ensure the electricity to the wires you are working on is shut off. Either remove the fuse or turn off the circuit breaker. Only the electrician or electrical engineer who has the qualified certification can be allowed to install this product.

### ASSEMBLY PART LIST

Part	Description	Quantity
①	Screw	2
②	Fixture Housing	1
③	Wire nuts	3
④	Diffuser	1
⑤	Wire Compartment Cover	1
⑥	Wire Compartment Cover Screw	1
⑦	Reflector	1
⑧	Drywall Anchor	2
⑨	Wood Screw	2

## INSTALLATION

### External Wiring Method\*

**STEP 1:** Remove diffuser ④ from housing ②: Near one end of housing, grasp edge of diffuser and carefully squeeze to release diffuser from housing. Continue down length of diffuser to fully disengage.

**STEP 2:** Remove fixture components and parts pack(s). Check that all parts are included.

**STEP 3:** To remove knockouts: Place standard screwdriver on center of slot and gently strike with hammer. Grip edge with pliers and flex back and forth until removed. Romex or other connector not supplied.

**STEP 4:** With the power turned off, thread two Screws ① into junction box (Note: screws must be the same distance apart as keyholes in back of housing assembly).

**STEP 5:** Hold the Fixture Housing ② firmly and connect the green ground wire from the fixture to the bare copper ground wire from the junction box using a Wire nut ③. (If house wiring does not include a ground wire, consult your local electrical code for approved grounding methods).

**STEP 6:** Use Wire nuts ③ to connect the black fixture wire to the black power supply wire and the white (neutral) fixture wire to the white power supply wire (See Figure 1).

**STEP 7:** Hold Fixture Housing ② in one hand and with the other hand position wires up into junction box.

**STEP 8:** Align keyholes on back of Fixture Housing with screws previously installed in junction box. Lift fixture up, rotate clockwise and tighten screws to secure Housing Assembly against ceiling.

**STEP 9:** To install diffuser ④: Starting at one end of housing, insert diffuser slot onto edge of housing (See Figure 2). Carefully squeeze diffuser to engage opposite side with housing. Continue this action down length of diffuser until fully installed onto housing.

**STEP 10:** Turn on electricity at fuse or circuit breaker box and verify success of installation.

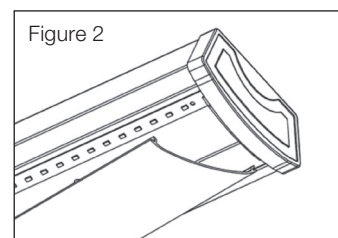
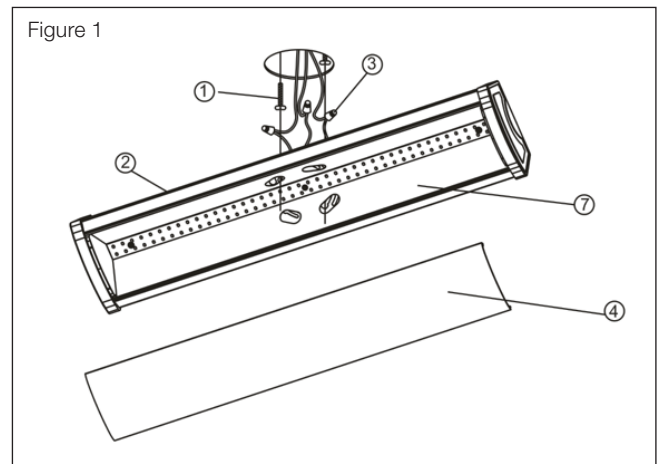

Specifications Model	WRA-20-***/Q121	WRA-40-***/Q151
Rated Wattage	20	40
Rated Voltage	120~277V, 50/60Hz	120~277V, 50/60Hz
Rated life (hrs)	50000 hrs	50000 hrs
Length L	622mm	1204mm
Breadth B	140mm	140mm
Height H	66mm	66mm

\* See back for Internal Wiring Method

## INSTALLATION

### Internal Wiring Method

**STEP 1:** Remove diffuser ④ from housing ②: Near one end of housing, grasp edge of diffuser and carefully squeeze to release diffuser from housing. Continue down length of diffuser to fully disengage.

**STEP 2:** Remove fixture components and parts pack(s). Check that all parts are included.

**STEP 3:** Pull the reflector ⑦ from one side to the middle. Note: Only the side of the reflector near the knockout can be pulled. (See Fig 4.)

**STEP 4:** Remove the wire compartment cover screw ⑥ from Wire Compartment Cover ⑤. Put the screw and Wire Compartment Cover in a place to avoid missing.

**STEP 5:** Remove the knockout on the back of the fixture in relationship to incoming power supply. Place standard screwdriver on center of slot and gently strike with hammer. Grip edge with pliers and flex back and forth until removed.

**STEP 6:** Pull the fixture wires (including the ground wire) of the fixture into the housing.

**STEP 7:** With the power turned off, pull the supply wires through the knockout of the fixture. Pull the wires through on the other side as much as you can without pulling them tight.

**STEP 8:** Position the Housing 2 against the Mounting surface and with a pencil, mark the screw hole locations to be located at the narrow section of the keyholes. (See Fig 5.)

**STEP 9:** Using a drill with a 1/16" drill bit, make two small pilot holes at the marked screw hole locations. If the fixture is being mounted to drywall, the drywall anchors ⑧ will need to be installed. To install the drywall anchors, drill two 3/16-in. pilot holes into the drywall. Insert the drywall anchors into the proper holes and tap the min to place so they are flush with the surface of the drywall.

**STEP 10: CEILING JOIST MOUNTING:** While holding the fixture in line with the pilot holes, screw the wood screws ⑨ into the wooden studs. Tighten until the fixture has been secured to the mounting surface.

**DRYWALL MOUNTING:** For mounting into drywall, hold your fixture in line with the drywall anchors that were installed, and screw all wood screws into the drywall anchors. Tighten until the fixture has been secured to the mounting surface.

**STEP 11:** Connect the green ground wire from the fixture to the bare copper ground wire from tube using a Wire nut ③. (If house wiring does not include a ground wire, consult your local electrical code for approved grounding methods).

**STEP 12:** Use Wire nuts ③ to connect the black fixture wire to the black power supply wire, the white (neutral) fixture wire to the white power supply wire. (See Fig 3.)

**STEP 13:** Attach the wire compartment cover ⑤ to the fixture using the wire compartment cover screw ⑥. Make sure none of the wires are protruding out of the wire compartment cover before fully tightening the screw.

**STEP 14:** Put the side of the reflector ⑦ back to its original position.

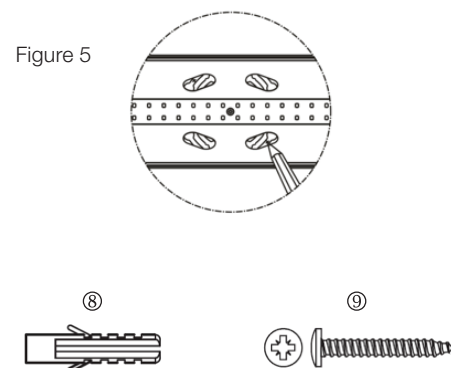
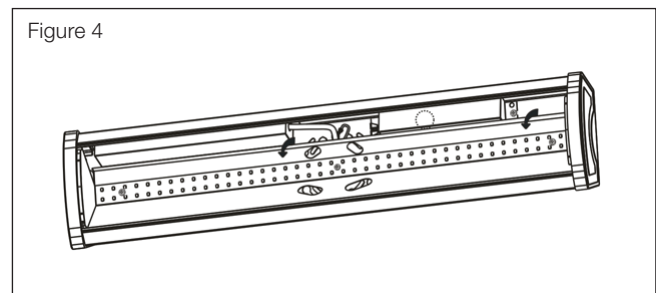
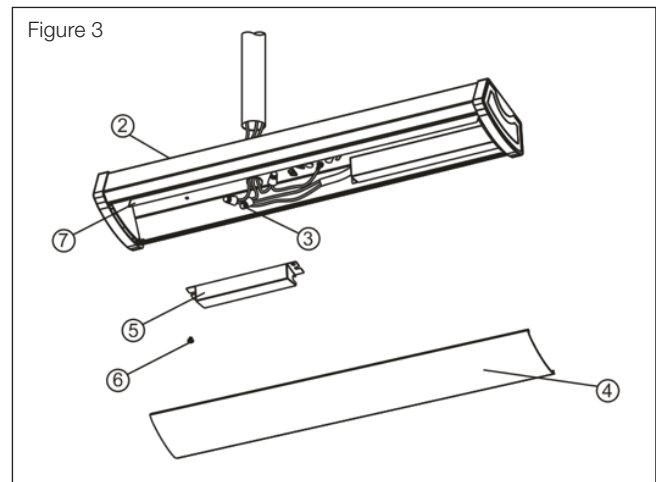

**STEP 15:** To install diffuser ④ – starting at one end of housing, insert diffuser slot onto edge of housing (See Fig. 2). Carefully squeeze diffuser to engage opposite side with housing. Continue this action down length of diffuser until fully installed onto housing.

**STEP 16:** Turn on electricity at fuse or circuit breaker box and verify success of installation.