

Installation Support • Soporte de instalación • Support d'installation

Personal Assistance, Product Specs, & "How-to" Questions:

Asistencia personal, especificaciones del producto y preguntas sobre "cómo hacerlo":
Aide personnelle, spécifications du produit et questions « pratico-pratiques » :

1-800-PFAUCET (732-8238)
pfisterfaucets.com/support

Installation Videos Available
Videos de instalación a disposición
Vidéos d'installation disponibles



pfisterfaucets.com/videos

▲ WARNING / AVERTENCIA / AVERTISSEMENT

To reduce the risk of injury or property damage, read all instructions before installing product. Wear safety goggles. Product must be installed in accordance with all state & local plumbing & building codes. Call a professional if you are uncertain about installing this product.

Para disminuir el riesgo de lesiones o daños a la propiedad, lea todas las instrucciones antes de instalar el producto. Utilice gafas de seguridad. El producto deberá instalarse de acuerdo con la normativa de plomería y construcción estatal y local. Llame a un profesional si no está seguro sobre cómo instalar este producto.

Pour réduire le risque de blessures ou de dommages, lisez toutes les instructions avant d'installer l'appareil. Porter des lunettes de sécurité. Il faut installer l'appareil en respectant tous les codes de construction et de plomberie locaux et d'État. Appelez un professionnel si vous n'êtes pas certain de la façon d'installer cet appareil.

Required Tools
Herramientas necesarias
Outils nécessaires



Plumber's Putty
Masilla para plomería
Mastic de plombier



Adjustable Wrench
Llave ajustable
Clé réglable



Safety Goggles
Anteojos de seguridad
Lunettes de sûreté

Additional Helpful Tools
Otras herramientas útiles
Outils supplémentaires utiles

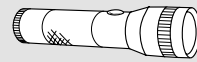

Flashlight
Linterna
Lampe De Poche



Cloth
Paño de limpieza
Chiffon

Parts in the Box • Piezas en la caja • Pièces dans la boîte

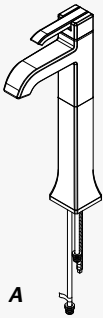

A



B



C



D



E (x2)



F (x2)

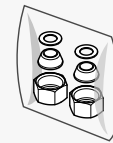

G



Aerator Tool
Herramienta para el aireador
Outil d'aérateur

1 Turn Off Water Supply • Cierre el suministro de agua • Couper l'alimentation en eau



Locate water supply inlets and shut off the water supply valves. These are usually found under the sink or near the water meter. If you are replacing an existing faucet, remove the old faucet from the sink and clean the sink surface thoroughly.

Ubique las entradas del suministro de agua y cierre las válvulas de suministro de agua. Generalmente se encuentran debajo del fregadero o cerca del medidor de agua. Si se trata de un reemplazo de grifo, quite el grifo viejo y limpie completamente la superficie del fregadero.

Repérer les arrivées d'eau et fermer leurs robinets. Ces robinets se trouvent généralement sous le lavabo ou à côté du compteur d'eau. En cas de remplacement d'un robinet existant, le déposer du lavabo et nettoyer soigneusement la surface de ce dernier.

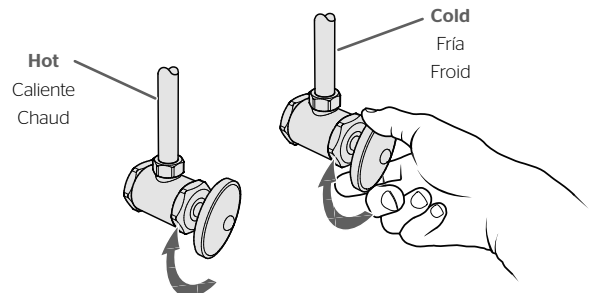

2 Install Spout Body

Instale la estructura del surtidor

Installez le corps du bec



Plumber's Putty
Masilla para plomería
Mastic de plombier

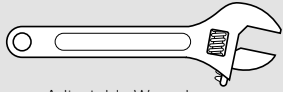

Adjustable Wrench
Llave ajustable
Clé réglable

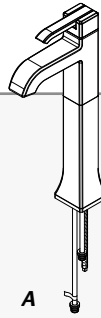

A



B



C



D

2A

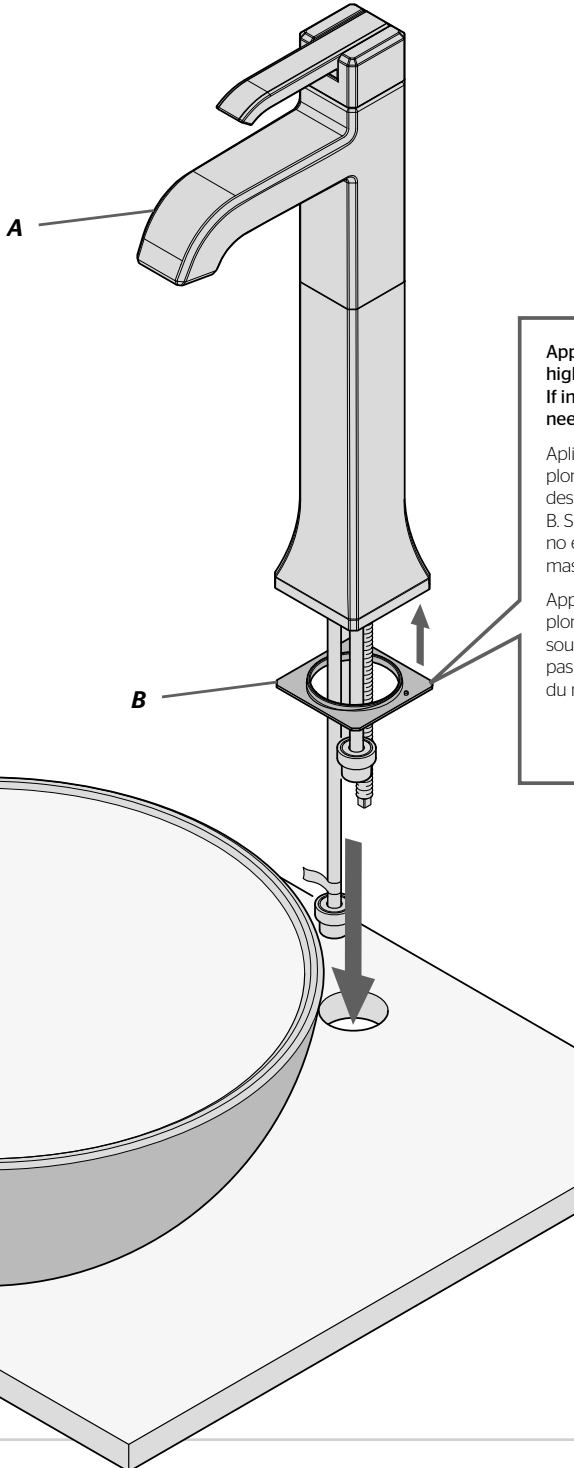

2B

Apply Plumber's Putty in highlighted grooves beneath B. If installing on marble, no putty needed.

Aplique masilla de plomero en los surcos destacados debajo de B. Si instala en mármol, no es necesario aplicar masilla.

Appliquez le mastic de plombier dans les rainures soulignées sous B. Le mastic n'est pas nécessaire si vous installez sur du marbre.

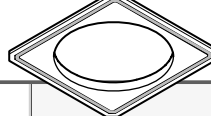

Make sure that the bumps on the metal washer (C) are facing up. Be sure the spout body (A) is centered & facing forward.

IMPORTANT: DO NOT OVERTIGHTEN.

Cerciórese que las protuberancias de la arandela metálica (C) estén orientadas hacia arriba. Cerciórese que la estructura del surtidor (A) esté centrada y orientada hacia adelante. **IMPORTANTE: NO APRIETE EXCESIVAMENTE.**

Vérifiez que les bosses sur la rondelle de métal (C) sont tournées vers le haut. Assurez-vous que le bec (A) est centré et tourné vers le haut. **IMPORTANT: NE PAS TROP SERRER.**

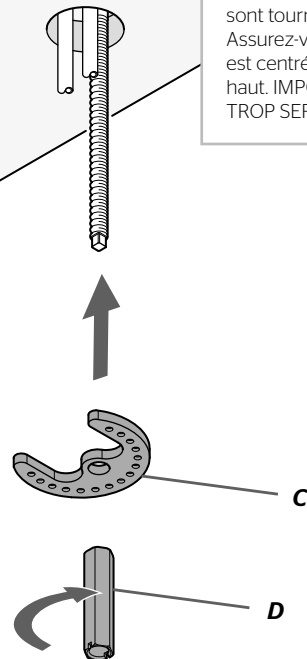

3

Connect Water Supply Lines

Conecte las tuberías de suministro de agua

Raccorder les conduites d'alimentation en eau

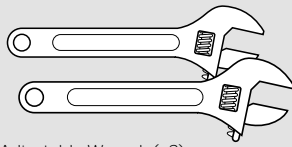

Adjustable Wrench (x2)
Llave ajustable (x2)
Clé réglable (x2)



G (x2) H (x2)

3A



Water Supply Lines not included. Please consult manufacturer and/or its instructions for the correct method of installation of supply lines & fittings.

IMPORTANT: Incorrect application of supply lines and fittings may result in the failure or leak of the supply lines and fitting.

Las tuberías de suministro de agua no están incluidas. Consulte por favor el fabricante y/o sus instrucciones para el método correcto de instalación de líneas de suministro y de guarniciones.

PRECAUCIÓN: El uso incorrecto de líneas de suministro y de guarniciones puede dar lugar a la falta o al escape de las líneas de suministro y de la guarnición.

Les tuyaux d'arrivée d'eau ne sont pas fournis. Veuillez consulter le fabricant et/ou ses instructions pour la méthode correcte d'installation des canalisations et des garnitures d'alimentation.

ATTENTION: L'application incorrecte des canalisations et des garnitures d'alimentation peut avoir comme conséquence l'échec ou la fuite des canalisations et de l'ajustage de précision d'alimentation.

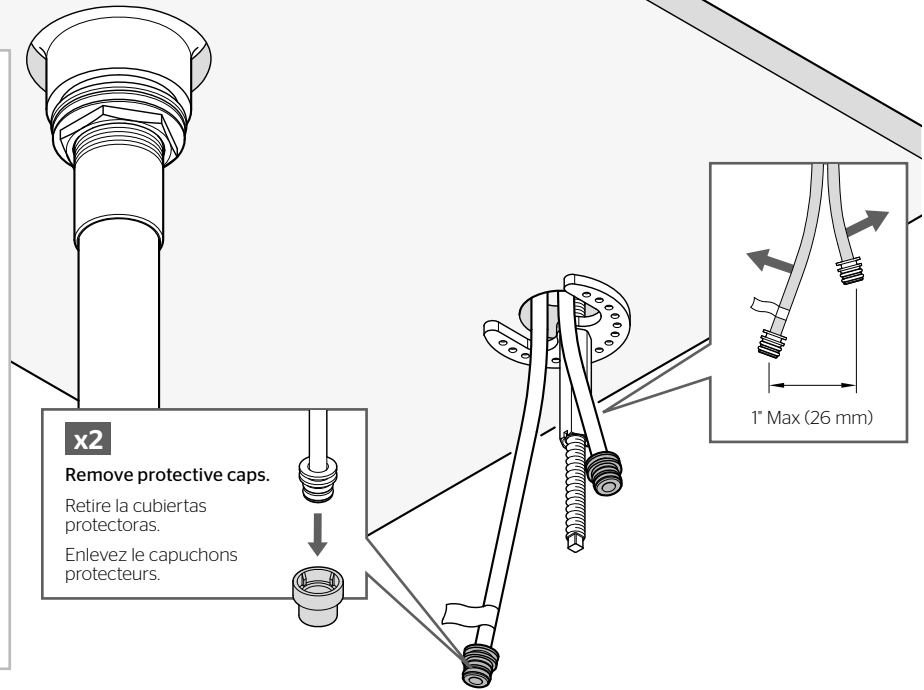

x2

Remove protective caps.

Retire la cubiertas protectoras.

Enlevez le capuchons protecteurs.

1" Max (26 mm)

3B

x2

Hot & Cold
Caliente y fría
Chaud et froid

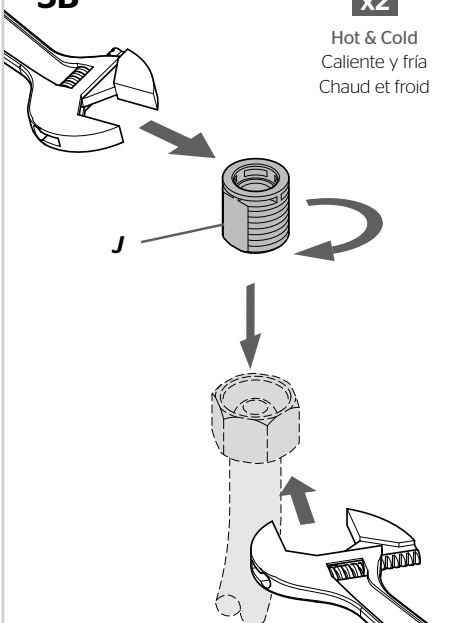

3C

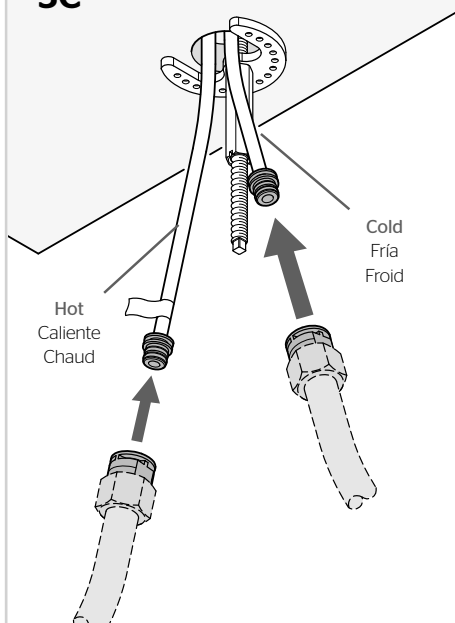

Hot
Caliente
Chaud

Cold
Fría
Froid

3D

x2

Hot & Cold
Caliente y fría
Chaud et froid

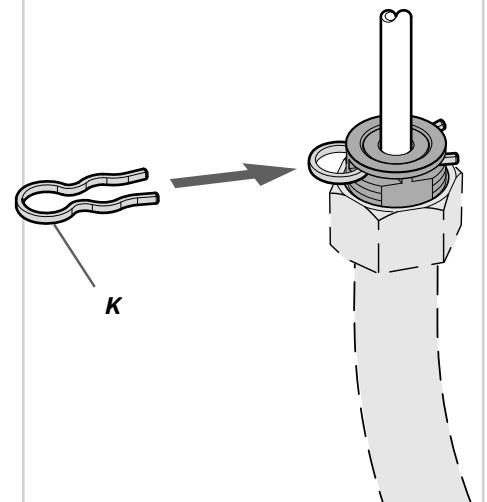

K

4 Turn On Water & Confirm Proper Installation

Active el suministro de agua y confirme que la instalación está adecuadamente efectuada

Ouvrez l'eau et confirmez que l'installation est adéquate

4A

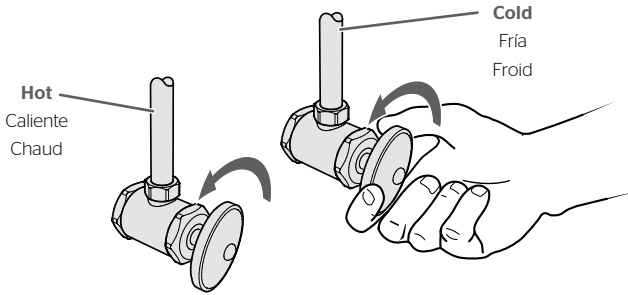

Faucet Functions • Funciones del grifo • Fonctions du robinet

Open
Abierta
Ouvverte

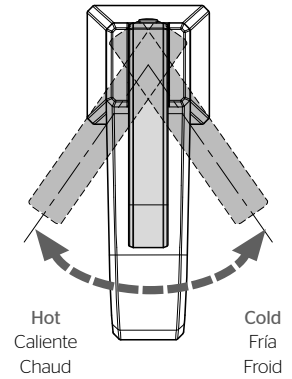
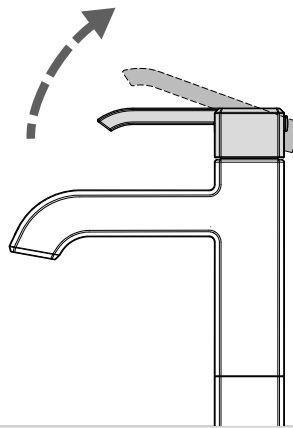

Check for leaks above and below the sink.

Revise si hay fugas encima y debajo del fregadero

Assurez-vous qu'il n'y a pas de fuite au dessus ou au dessous du lavabo

5 Flush the Faucet

Enjuague el grifo

Vidanger l'robinet

5A

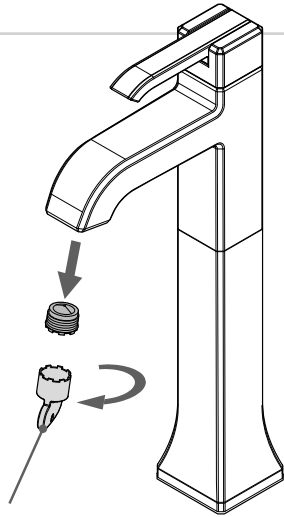

Use aerator tool to remove aerator.

Utilice la herramienta del aireador para retirarlo.

Utilisez l'outil d'aérateur pour enlever l'aérateur.

5B

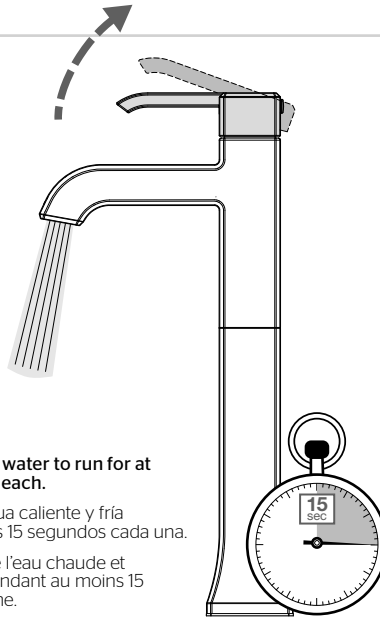

Allow hot & cold water to run for at least 15 seconds each.

Deje correr el agua caliente y fría durante al menos 15 segundos cada una.

Laissez couler de l'eau chaude et de l'eau froide pendant au moins 15 secondes chacune.

5C

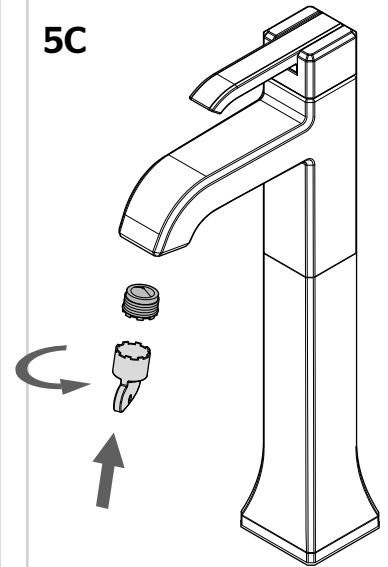

For Additional Installation Help:
Para la instalación adicionales de ayuda:
Pour aider à l'installation supplémentaires:

Pfister

1-800-PFAUCET (732-8238)
pfisterfaucets.com