



CITY BOSS™

Residential City Water Pressure Booster System

CITY BOSS is a city water pressure booster system utilizing the MASCONTROL® pump controller and a single-stage pressure booster pump. The pump controller monitors both flow and pressure, controlling the operation of the pump automatically. The system maintains constant boosted water pressure during operation. No pressure tank or switch is required. No adjustment or maintenance is needed.



CITY BOSS RESIDENTIAL CITY WATER PRESSURE BOOSTER SYSTEM

CITY BOSS SYSTEM INCLUDES:

- MASCONTROL hydraulic/electronic pump controller.
- Heavy-duty cast iron booster pump fitted with thermoplastic impeller and diffuser designed for quiet operation.
- Single-phase capacitor start, open drip-proof motor with 14/3 SJTW cord set attached.
- Pipe fitting to connect pump controller to pump (required for system 1-SK75BOSS125 only).

FEATURES:

- System maintains constant water pressure during operation.
- Dual voltage 115V or 230V.
- 1¼" FNPT pump inlet (can be connected to minimum ¾" pipe size city pressure supply).
- Controller shuts off the pump in event of water failing to reach the pump inlet.
- Controller starts and stops the pump when tap is opened and closed (optional small pressure tank for small uses such as ice makers, glasses of water, etc., may be used. Consult installation manual or contact factory).
- Assists in absorbing water hammer.
- Built-in backflow preventer and short-cycle protection.

CITY BOSS SYSTEM MODEL NUMBER	HP	CONNECTIONS		SERVICE FLOW GPM															
		PUMP INLET	MASCONTROL OUTLET	0	2	4	6	8	10	12	14	16	18	20	22	25	30	35	
				PRESSURE BOOST PSI															
1-SK50BOSS1	½	1 ¼" FNPT	1" MNPT	39	38	37	36	35	34	33	31	29	27	24	21	-	-	-	
1-SK75BOSS125	¾	1 ¼" FNPT	1 ¼" MNPT	43	43	43	42	42	41	41	40	39	38	36	35	33	28	21	

Above chart PSI values have accounted for pressure loss thru the pump controller at flow rates indicated. Booster pump is designed for city water pressurized supply, not well water flooded or suction lift application.



CITY BOSS™

Residential City Water Pressure Booster System MODELS 1-SK50BOSS1, 1-SK75BOSS125

BOOSTER PUMP MODELS SK50, SK75

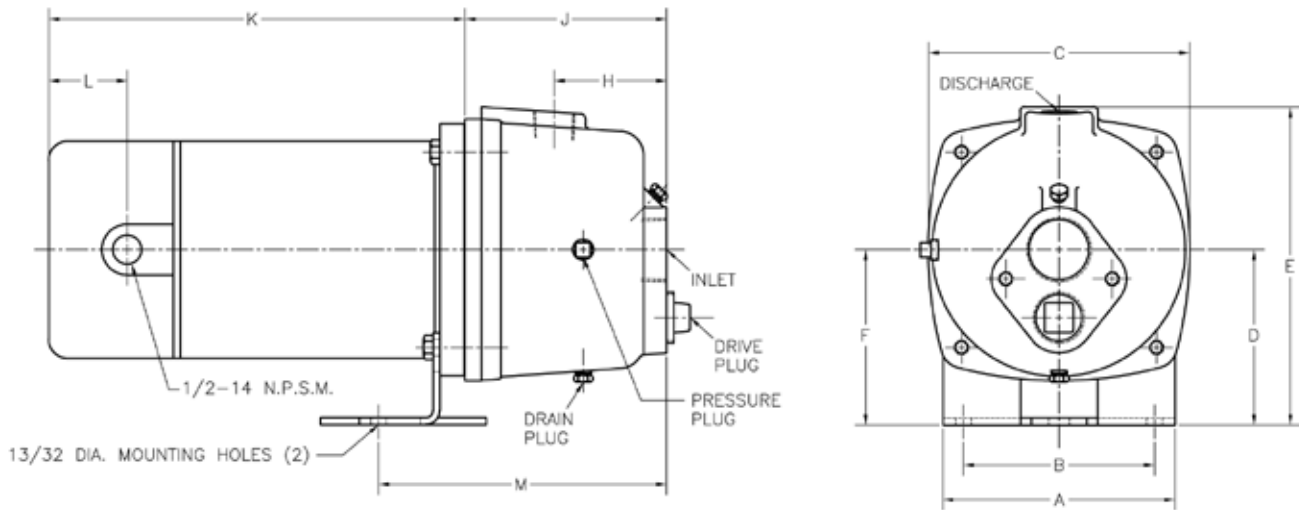

BOOSTER PUMP DIMENSIONS

PUMP MODEL	INLET	DRIVE PLUG	DISCHARGE	A	B	C	D	E	F	H	J	K	L	M	PRESSURE PLUG	DRAIN PLUG
SK50	1-1/4 NPT	1 NPT	1 NPT	6	4.94	6.75	4.51	8.20	4.51	2.91	5.21	10.75	1.25	7.44	1/4 NPT	1/8 NPT
SK75	1-1/4 NPT	1 NPT	1 NPT	6	4.94	6.75	4.51	8.20	4.51	2.91	5.21	12.25	1.25	7.44	1/4 NPT	1/8 NPT

General notes for estimating only. All dimensions are in inches.
Dimensions K and L represent NIDEC - US MOTOR brand motors and may vary with other brands.

MASCONTROL PUMP CONTROLLER MODELS MCA, MCB

PUMP CONTROLLER DIMENSIONS

MODEL	MCA	MCB
LANCASTER PART NUMBER	1-BOSS1	1-BOSS125
INLET	1 MPT	1-1/4 MPT
OUTLET	1 MPT	1-1/4 MPT
R	4.75	4.75
T	7.13	7.13
X	6.63	7.25
Y	9.75	10
Z	6.50	6.88
CONDUIT CONNECTION	1/2 FPT	1/2 FPT

General notes for estimating only. All dimensions are in inches.

