



# SERVICE PARTS LIST

**BULLETIN NO.**  
**54-43-2440**

SPECIFY CATALOG NO. AND SERIAL NO. WHEN ORDERING PARTS		REVISED BULLETIN	DATE
M12™ 3/8" CROWN STAPLER			July 2017
CATALOG NO.	2447-20	STARTING SERIAL NO.	J07A
WIRING INSTRUCTION			

**EXAMPLE:**  
Component Parts (Small #)  
Are Included When Ordering  
The Assembly (Large #).

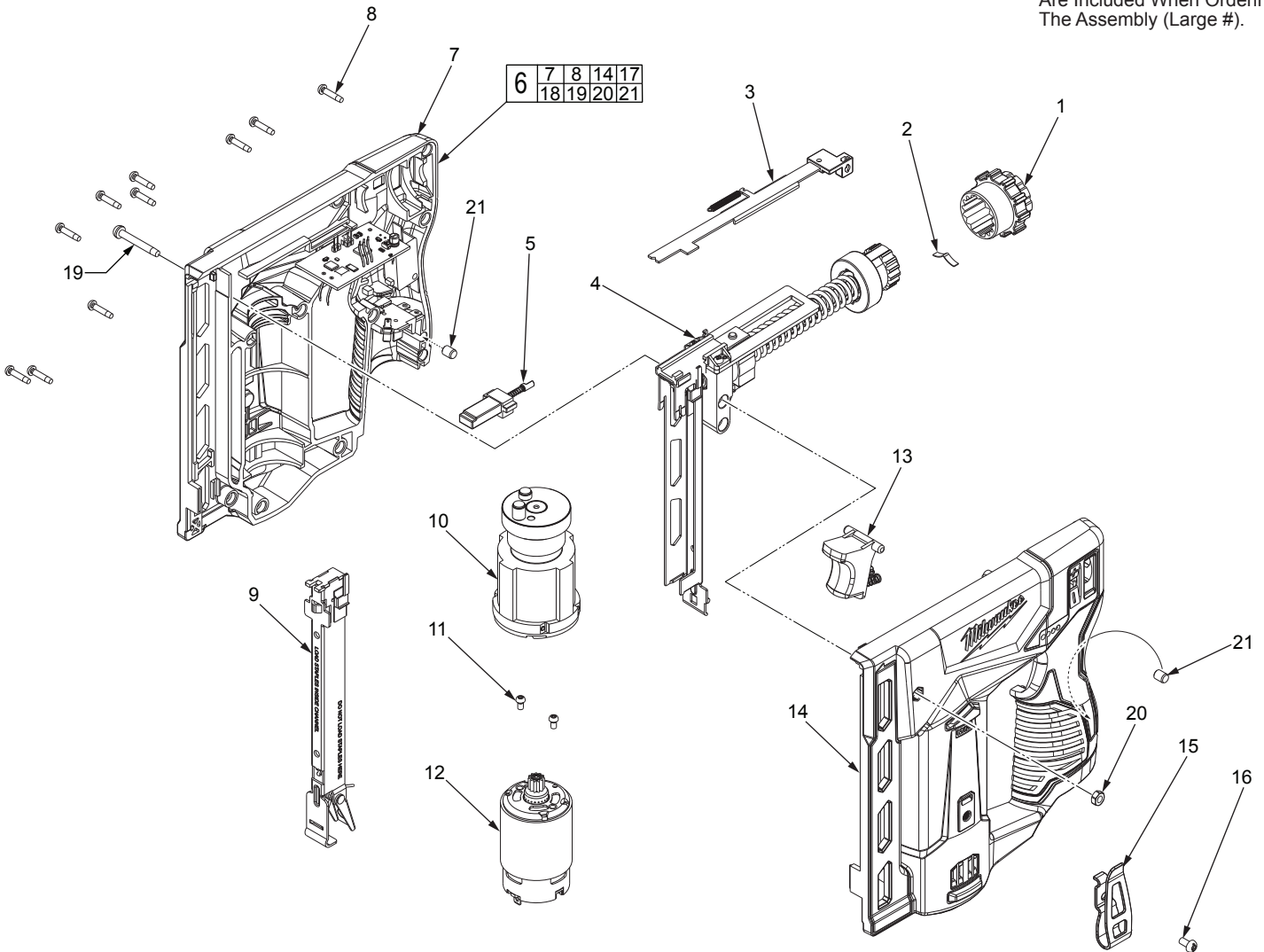

FIG.	PART NO.	DESCRIPTION OF PART	NO. REQ.
1	45-94-0005	Adjustment Knob	(1)
2	40-50-0027	Spring Plate	(1)
3	44-94-0005	Workpiece Contact Assy.	(1)
4	44-62-0005	Striker Assy.	(1)
5	44-26-0005	Magnet Kit	(1)
6	14-20-2015	Electronics and Housing Assy.	(1)
7	-----	Right Housing	(1)
8	-----	M3 x 14 Screw	(10)
9	43-40-0065	Magazine Core Assy.	(1)
10	14-30-2005	Gear Case Assy.	(1)
11	05-88-0920	M3 x 5 Screw	(2)
12	14-50-0005	Motor Assy.	(1)
13	23-66-0005	Trigger with Spring	(1)
14	-----	Left Housing	(1)
15	42-70-0095	Belt Clip	(1)
16	06-82-0130	6-32 x .75" Screw	(1)
17	12-20-2447	Service Nameplate (Not Shown)	(1)
18	10-20-2447	Warning Label (Not Shown)	(1)

FIG.	PART NO.	DESCRIPTION OF PART	NO. REQ.
19	-----	M4 x 36.5 Pan Hd. Washer T-20 Screw	(1)
20	-----	M4 Hex Nut	(1)
21	45-30-1000	Rubber Slug	(2)

**FIG. NOTES**  
17, 18 A clean, dry surface is essential for proper performance for any adhesive system. The area intended for application of any adhesive label or nameplate must be prepared by cleaning with isopropyl alcohol. The solvent is to be applied with a clean, lint free applicator and the surface allowed to dry before applying the label or nameplate.