

NOTES:

- (N1) 1. FIT / FORM / FUNCTION SHALL FOLLOW PS-E.008.
- 2. APPLY LOCTITE 680.
- 3. SLIT AND SHORTEN O-RING BY .13" TO .20" IN LENGTH BEFORE INSTALLING.
- 4. SLIT O-RING BEFORE INSTALLING.
- 5. INSTALLATION TORQUE: 8 -14 LB-FT.
- (N2) 6. WATER TEST WHOLE UNIT.
- 7. BAG 5-007 IN A SEPARATE BAG.
- 8. APPLY THIN FILM OF DOW CORNING III.
- 9. APPLY LOCTITE 242.

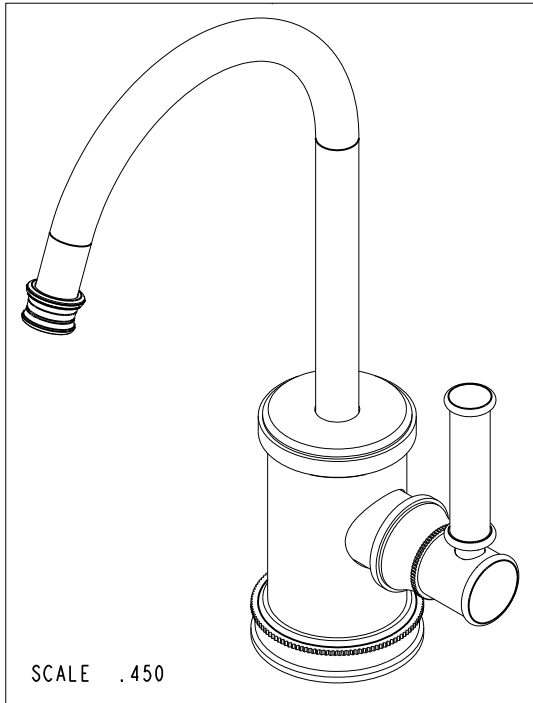

BILL OF MATERIAL (CURRENT LEVEL)

ITEM	PT/ASSY	DESCRIPTION	TYPE	QTY.
1	1-134	CARTR 3/8 HOT 1/4 TR	PART	1
2	5-007	1/4 COMP KIT	ASSEMBLY	1
3	10514	MOUNTING CRESCENT	PART	1
4	10516	MOUNTING NUT	PART	1
5	10661	MOUNTING STUD	PART	1
6	11733	SHELL, SPOUT, WATER DISP	PART	1
7	11834	ADAPTER	PART	1
8	12511	ESCUTCHEON	PART	1
9	12512	BONNET	PART	1
10	12513	BODY CAP	PART	1
11	12514	LEVER HANDLE	PART	1
12	12515	HANDLE HUB	PART	1
13	12549	BODY	PART	1
14	50713	SPOUT, WATER DISP. (TRAD.)	PART	1
15	50714	WATER DISP. CAR.T HOLDER	PART	1
16	50760	NIPPLE WATER DISP	PART	1
17	91017	O-RING, #2- 012, EPDM, 65-75 DURO, NSF 61	PART	2
18	91023	O-RING, #2- 019, EPDM, 65-75 DURO, NSF 61	PART	1
19	91063	MOUNTING CRESCENT GASKET	PART	1
20	91362	O-RING, #2-130, EPDM, 65-75 DURO	PART	1
21	91382	O-RING, #2- 012, TEFLON,	PART	1
22	91383	O-RING, #2- 014, TEFLON, NSF 61	PART	1
23	92192	SCRW, 10-32 X 5/8 SKT HD CUP PT SS	PART	1
24	92477	SCRW, M4 X 16 SKT FLT HD SS	PART	1

SCALE .450

UNITS ARE: INCHES [MM]
 TOLERANCES ARE:
 FRACTIONS DECIMALS ANGLES
 $\pm 1/16"$ $.X \pm .1$ [2.5] $\pm 1^\circ$
 $.XX \pm .06$ [1.5]
 (X.XXX) DENOTES CRITICAL DIMS.
 ALL THREADS ARE CRITICAL

BRASSTECH 2001 CARNEGIE AVE.
 INCORPORATED SANTA ANA, CA 92705
 (949) 417-5207

COLD WATER DISPENSER

-	A	EN-3298	3/31/17	J.A.
-	-	EN-2980	09/12/16	V.V.
ZONE	REV	DESCRIPTION	DATE	APPROVED

COPYRIGHT 2005 BRASSTECH, INC.
 THESE DRAWINGS AND THE DESIGNS
 DEPICTED HEREIN ARE THE PROPRIETARY
 PROPERTY OF BRASSTECH. ANY USE
 OR REPRODUCTION IS SUBJECT TO
 THE EXPRESS APPROVAL OF BRASSTECH.
 UNAUTHORIZED USE IS STRICTLY
 PROHIBITED. ALL RIGHTS RESERVED.

TESTING	-	-	-
ASSEMBLY	-	-	-
PLATING	-	-	-
POLISHING	-	NEXT ASSY	USED ON
MACHINING	-	APPLICATION	
TOOLING FIXTURE #	REMOVE ALL BURRS AND SHARP EDGES		

DRAWN	AMARISH	09/15/16
CHECKED	RAVINDRA	09/15/16
APPROVED	V. VU	09/15/16

DWG NO.	2940-5623	REV	A
SCALE	.250	REF.	-
SHEET	1	OF	3

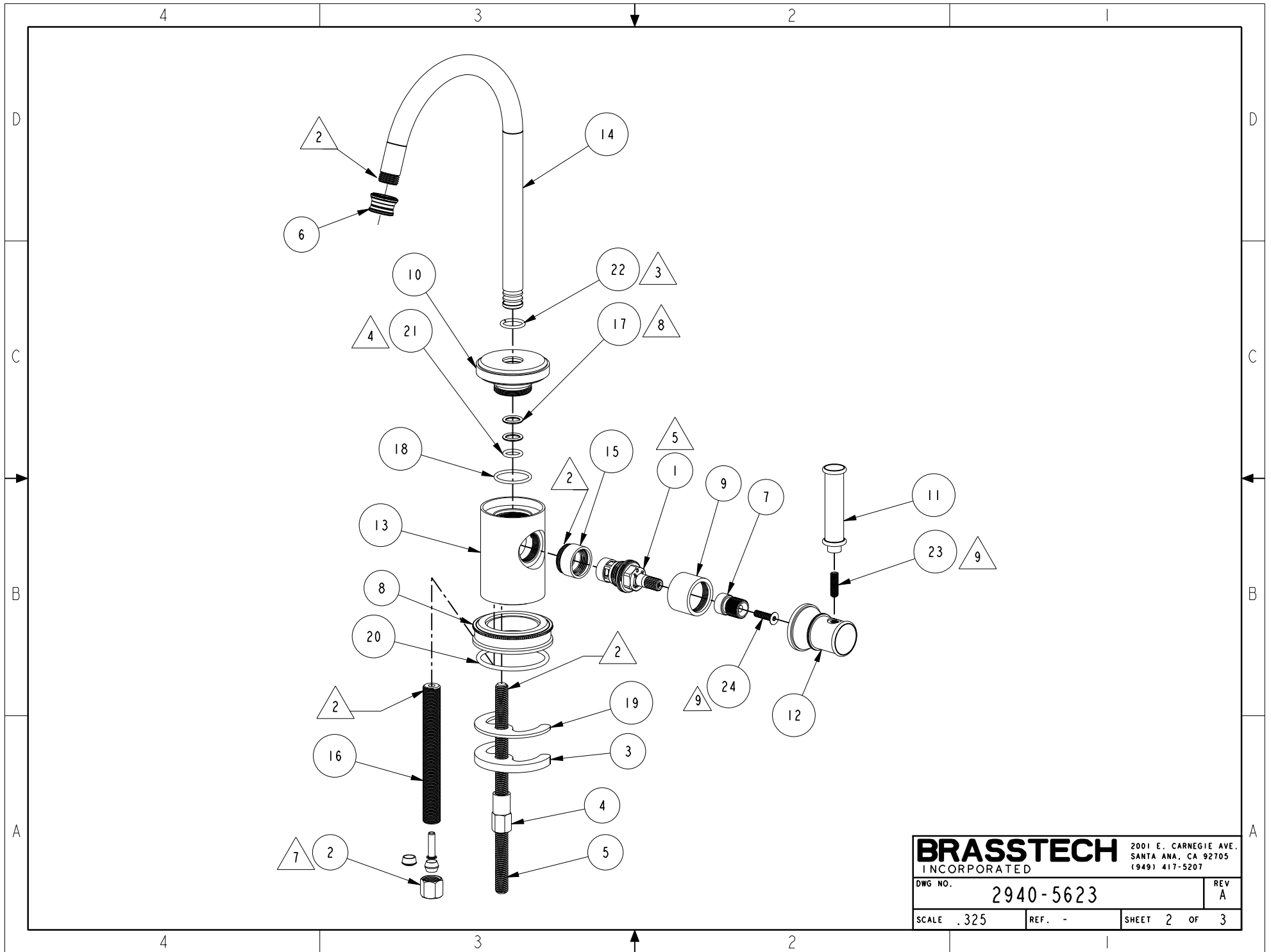

BRASSTECH		2001 E. CARNEGIE AVE.
INCORPORATED		SANTA ANA, CA 92705
		(949) 417-5207
DWG NO.	2940-5623	REV A
SCALE .325	REF. -	SHEET 2 OF 3

