

NOTES:

1. TO INSPECT ASSEMBLY, FOLLOW FIRST ARTICLE AND IN PROCESS INSPECTION SHEET.
2. PACK THESE ITEMS IN A PLASTIC BAG.
3. HANDLE IN CLOSE POSITION.
4. INSTALLATION TORQUE 11-14 LB-FT.
5. INSTALLATION TORQUE 4-6 LB-FT.
6. APPLY LOCTITE 680.
7. APPLY LOCTITE 242
8. APPLY LOCTITE 242 ONLY AFTER ADJUSTING HANDLES IN THEIR OPTIMAL POSITION.
9. SWIVEL CONNECTION SHALL NOT HAVE NOTICEABLE WOBBLINESS AFTER ASSEMBLY.

BILL OF MATERIAL (CURRENT LEVEL)

ITEM	PT/ASSY	DESCRIPTION	TYPE	QTY.
1	11330	VALVE BODY, WALL-END	PART	1
2	11309	FLANGE, MOUNTING	PART	1
3	92231	SCRW, 1/4-20 X 1/4 SKT HD CUP PT SS	PART	1
4	92223	SCRW, #8 X 2-1/2 PHL FLT HD SS	PART	4
5	2-556	FLANGE ASM, CONTEMP	ASSEMBLY	1
6	2-553	LOWER ARM ASM, CONTEMP	ASSEMBLY	1
7	2-552	UPPER ARM ASM, CONTEMP	ASSEMBLY	1
8	1-326	W/S CARTRIDGE FRICTION - HOT	PART	1
9	1-437	CARTR 3/8 HOT 1/4 TR	PART	1
10	11834	ADAPTER	PART	2
11	92477	SCRW, M4 X 16 SKT FLT HD SS	PART	2
12	12515	HANDLE HUB	PART	2
13	12514	LEVER HANDLE	PART	2
14	92192	SCRW, 10-32 X 5/8 SKT HD CUP PT SS	PART	2

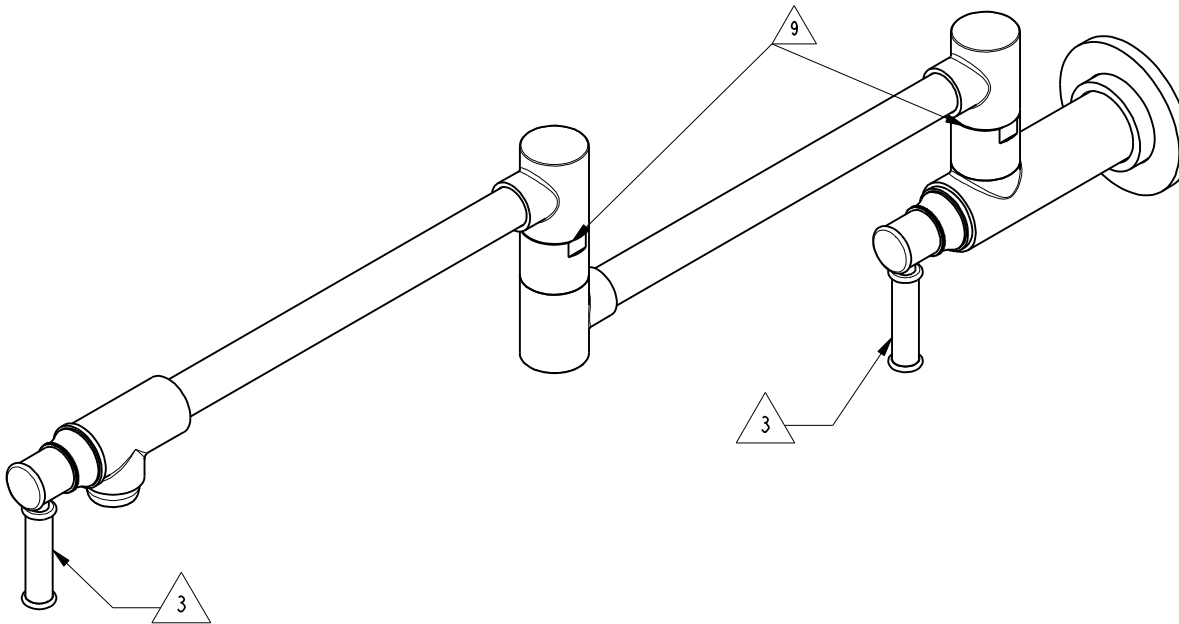

-	E	EN-4300q	11/20/20	R.S.
-	D	EN-4112	03/24/20	G.B.
-	C	EN-3756	11/22/18	C.G.
-	B	EN-3495	03/26/18	J.A.
-	A	EN-3293	3/31/17	J.A.
-	-	EN-2980	09/27/16	V.V.
ZONE	REV	DESCRIPTION	DATE	APPROVED

COPYRIGHT 2005 BRASSTECH, INC. THESE DRAWINGS AND THE DESIGNS DEPICTED HEREIN ARE THE PROPRIETARY PROPERTY OF BRASSTECH. ANY USE OR REPRODUCTION IS SUBJECT TO THE EXPRESS APPROVAL OF BRASSTECH. UNAUTHORIZED USE IS STRICTLY PROHIBITED. ALL RIGHTS RESERVED.

TESTING	-	-	-
ASSEMBLY	-	-	-
PLATING	-	-	-
POLISHING	-	NEXT ASSY	USED ON
MACHINING	-	APPLICATION	
TOOLING FIXTURE #	REMOVE ALL BURRS AND SHARP EDGES		

UNITS ARE: INCHES [MM]		
TOLERANCES ARE:		
FRACTIONS DECIMALS	ANGLES	
±1/16"	.X ±.1 [2.5]	±1°
	.XX ±.06 [1.5]	
(X.XXX) DENOTES CRITICAL DIMS. ALL THREADS ARE CRITICAL		
DRAWN	JINSON	11/20/20
CHECKED	R.S.	11/20/20
APPROVED	R.S.	11/20/20

BRASSTECH 2001 CARNEGIE AVE. SANTA ANA, CA 92705 (949) 417-5207
INCORPORATED

POT FILLER - WALL MOUNT

DWG NO.	2940-5503	REV	E
SCALE	.300	REF.	-
SHEET	1	OF	3

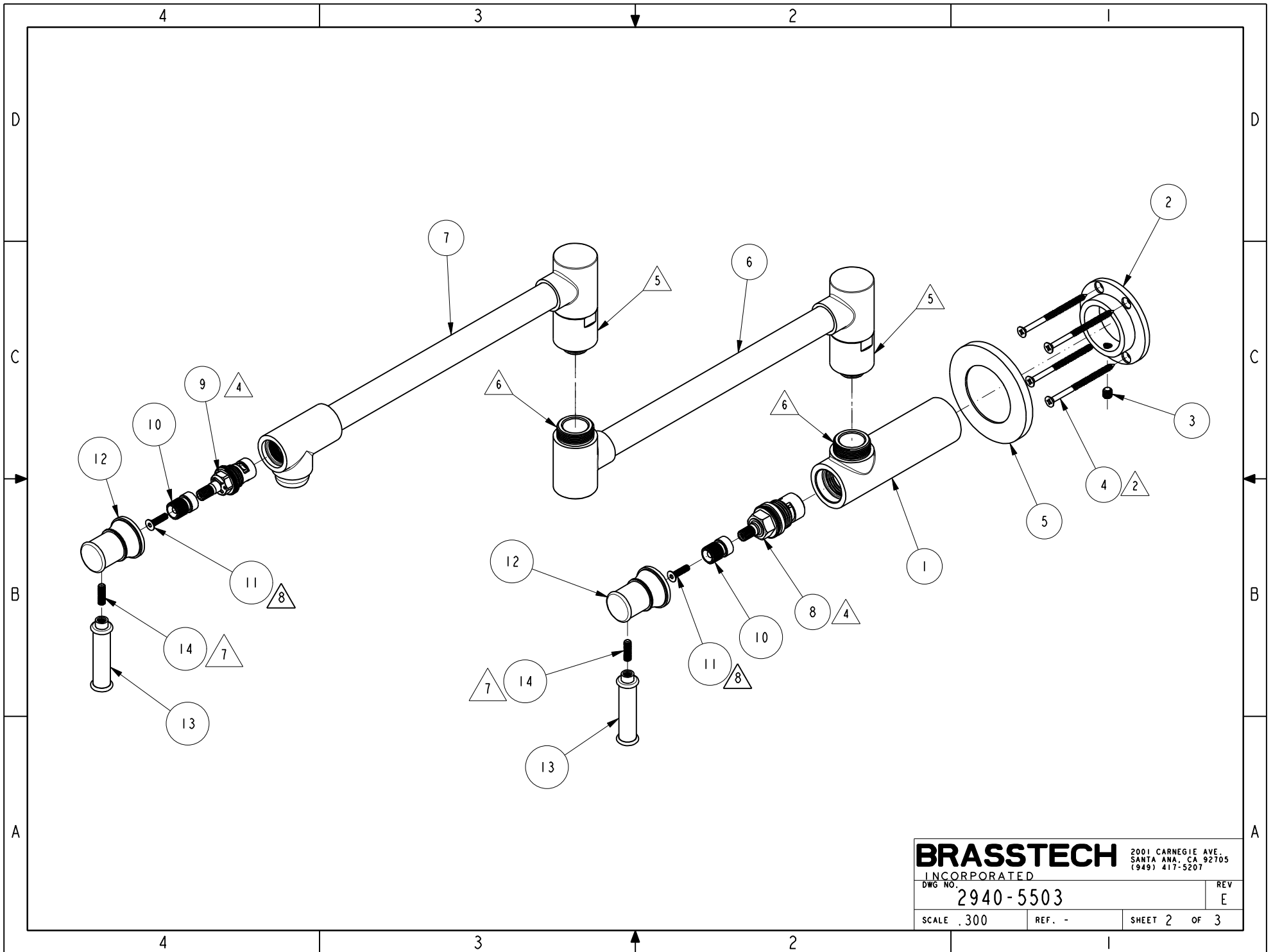

BRASSTECH 2001 CARNEGIE AVE.
 INCORPORATED SANTA ANA, CA 92705
 (949) 417-5207

DWG NO. 2940-5503	REV E
SCALE .300	REF. -
SHEET 2 OF 3	

