

Installation & Operation Manual

Zone Valve Control 306V



Zoning

306V_D

11/16

Replaces: 10/16

Introduction

The Zone Valve Control 306V connects up to six thermostats and operates zone valves to provide heating to a zoned hydronic heating system. The 306V operates a system pump whenever a zone valve opens. Zone 1 can operate either a zone valve or a circulator to provide heat to an indirect domestic hot water tank with optional priority over zones 2 through 6. The 306V includes optional exercising to prevent circulator seizure when not in use, and optional post purge operation of the domestic hot water tank to maximize energy savings. The 306V provides a RoomResponse™ signal to modulating-condensing boilers to optimize comfort while improving boiler efficiency.

Features

- RoomResponse™ signal
- Compatible with all 24 V (ac) thermostats
- Compatible with 2, 3 and 4-wire zone valves
- Unlimited zone expansion
- Zone priority
- Priority override
- Pump exercising
- Post purge
- LED for each zone, priority, end switch and RoomResponse™
- Away signal shared between thermostats
- Four ground screws
- Top, bottom and back conduit knockouts
- Fuses protect transformers and pumps
- Two spare fuses included
- CSA approved

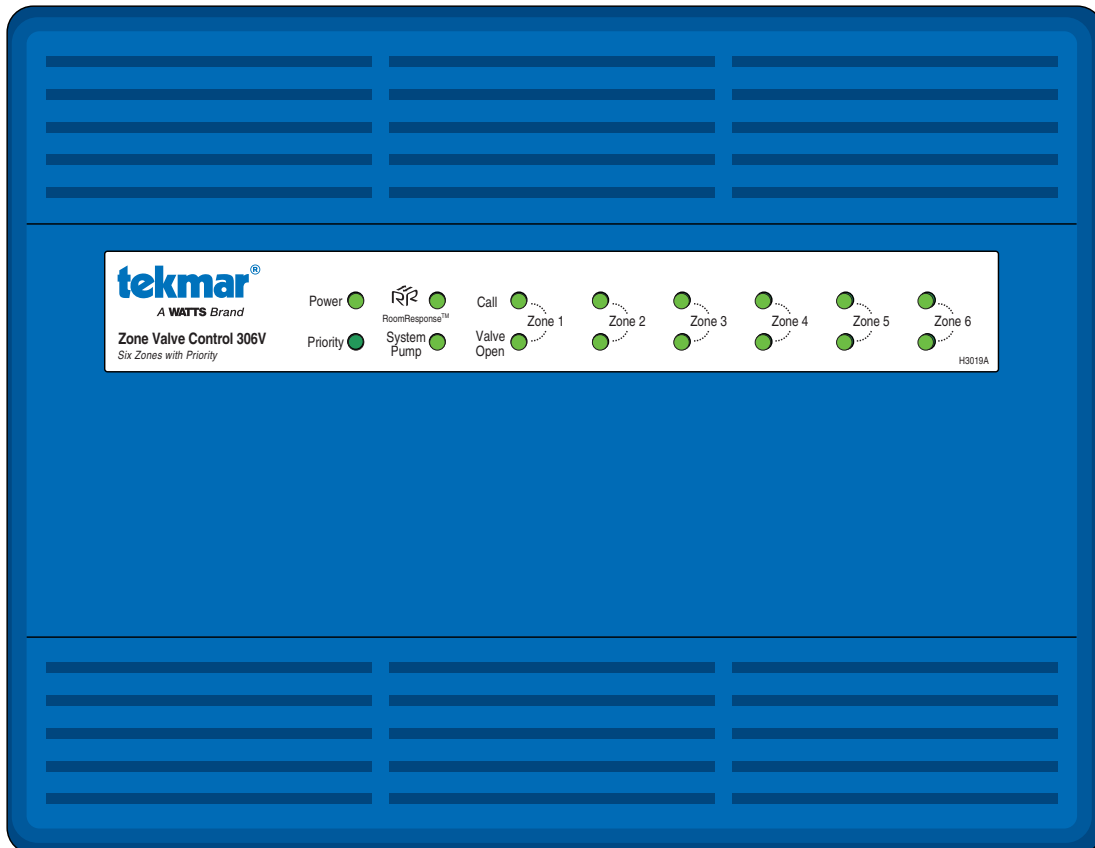

Table of Contents

Important Safety Information.....	2	User Interface.....	7
Installation.....	3	Indicator LED.....	7
Preparation.....	3	Sequence of Operation.....	7
Location.....	3	Technical Data.....	8
Installing the Enclosure.....	3	Limited Warranty and Product Return Procedure.....	8
Application 306V-1.....	4		
Application 306V-2.....	5		
Application 306V-3.....	6		

Important Safety Information

It is your responsibility to ensure that this control is safely installed according to all applicable codes and standards. tekmar is not responsible for damages resulting from improper installation and/or maintenance.



This is a safety-alert symbol. The safety alert symbol is shown alone or used with a signal word (DANGER, WARNING, or CAUTION), a pictorial and/or a safety message to identify hazards. When you see this symbol alone or with a signal word on your equipment or in this manual, be alert to the potential for death or serious personal injury.



This pictorial alerts you to electricity, electrocution, and shock hazards.

⚠ WARNING

This symbol identifies hazards which, if not avoided, could result in death or serious injury.

⚠ CAUTION

This symbol identifies hazards which, if not avoided, could result in minor or moderate injury.

NOTICE

This symbol identifies practices, actions, or failure to act which could result in property damage or damage to the equipment.

⚠ WARNING



Read manual and all product labels BEFORE using the equipment. Do not use unless you know the safe and proper operation of this equipment. Keep this manual available for easy access by all users. Replacement manuals are available at tekmarControls.com

⚠ WARNING

- It is the installer's responsibility to ensure that this control is safely installed according to all applicable codes and standards.
- Improper installation and operation of this control could result in damage to the equipment and possibly even personal injury or death.
- This control is not intended for use as a primary limit control. Other controls that are intended and certified as safety limits must be placed into the control circuit.

NOTICE

The control includes fuses and transformer that are serviceable. Do not attempt to service any other parts on the control. Attempting to service the control voids the warranty.

NOTICE

- Strip all wiring to a length of 3/8 in. or 10 mm for all terminals.
- A circuit breaker or power disconnect that provides power to the control should be located nearby and clearly labeled.
- Refer to the current and voltage ratings at the back of this manual before connecting devices to this control.

Radio Frequency Interference

The installer must ensure that this control and its wiring are isolated and/or shielded from strong sources of electromagnetic noise. Conversely, this Class B digital apparatus complies with Part 15 of the FCC Rules and meets all requirements of the Canadian Interference-Causing Equipment Regulations. However, if this control does cause harmful interference to radio or television reception, which is determined by turning

the control off and on, the user is encouraged to try to correct the interference by re-orientating or relocating the receiving antenna, relocating the receiver with respect to this control, and/or connecting the control to a different circuit from that to which the receiver is connected.

Cet appareil numérique de la classe B respecte toutes les exigences du Règlement sur le matériel brouilleur du Canada.

Installation

Preparation

Tools Required

- tekmar or jeweler screwdriver
- Phillips head screwdriver
- Needle-nose pliers
- Wire stripper

Materials Required

- 18 AWG LVT solid wire (low-voltage connections)
- 14 AWG solid wire (line-voltage connections)
- Four 1/8" - 1" wood screws

Packaging Contents

- 1 Zone Valve Control 306V
- 2 Spare fuses (located in cover)
- 1 Installation and Operation Manual 306V_D

Location

NOTICE

- Keep the control dry. Avoid potential leakage onto the control.
- Maintain relative humidity less than 90% in a non-condensing environment.
- Avoid exposure to extreme temperatures beyond 32-122°F (0-50°C).
- Install away from equipment, appliances, or other sources of electrical interference.
- Install to allow easy access for wiring, viewing, and adjusting the display screen.
- Install approximately 5 feet (1.5 m) off the finished floor.
- Locate the control near pumps and/or zone valves if possible.
- Provide a solid backing which the enclosure can be mounted to. Example: plywood or wall studs.
- Use the conduit knockouts provided on the upper, lower, and back of the enclosure for wiring.

Installing the Enclosure

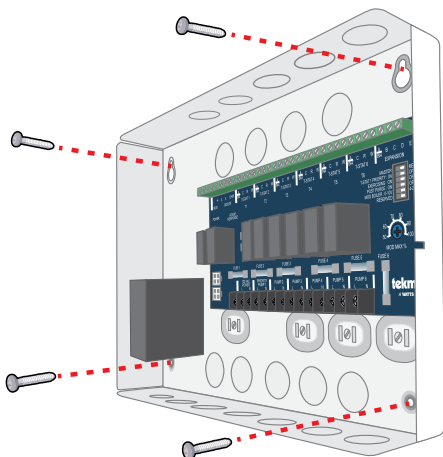

⚠ WARNING



To prevent the risk of personal injury and/or death, make sure power is not applied to the control until it is fully installed and ready for final testing. All work must be done with power to the circuit being worked on turned off.

Please be aware local codes may require this control to be installed or connected by an electrician.

Application 306V-1

The Zone Valve Control 306V operates six heating zones. When the thermostat calls for heat, the zone valve opens, the system pump is turned on and the boiler is fired.

Mechanical

Legend

- B1 = Boiler
- PS = System Pump
- T1 = WiFi Thermostat 561 or 562
- T2 to T4 = Thermostat 518 or 519
- T5 = Generic Digital Power-Stealing Thermostat
- T6 = Generic Bi-Metallic Strip Thermostat
- V1 to V6 = 2-Wire Zone Valves

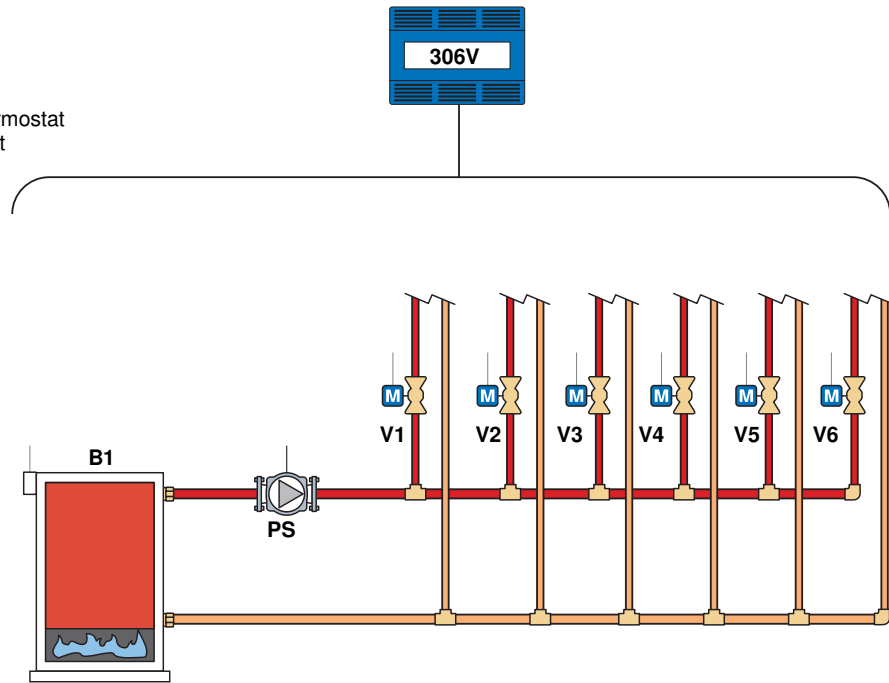

Electrical

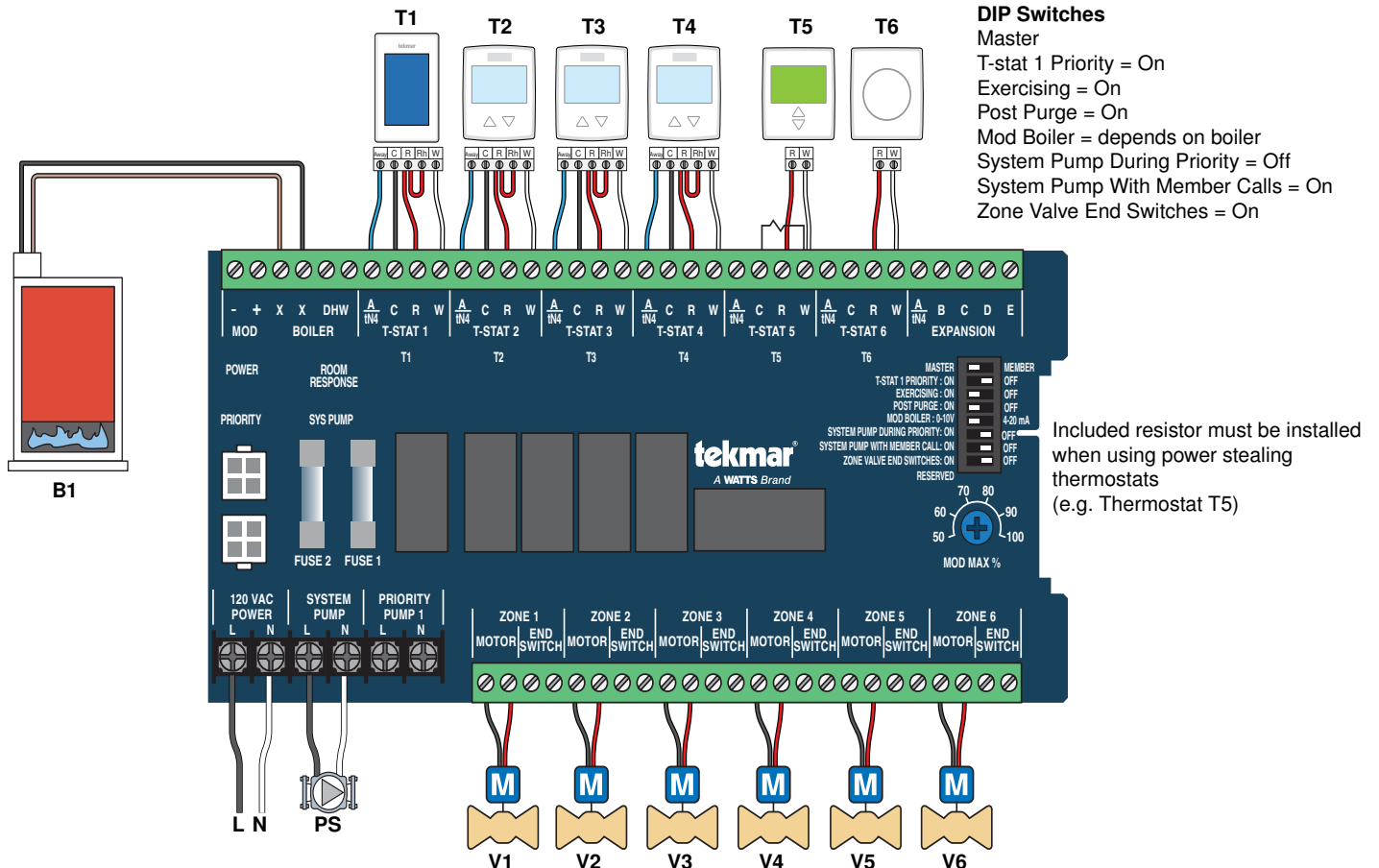

Application 306V-2

The Zone Valve Control 306V operates a five heating zones and a domestic hot water tank. When a thermostat calls for heat, the zone valve opens and the system pump and the boiler turn on once the zone valve end switch closes. The domestic hot water tank is heated using a pump. When priority is selected, the heating zones are shut off while the hot water tank is heated.

Mechanical

Legend

- | | |
|-----------------------------------|--|
| A1 = DHW Tank Aquastat | T2 to T3 = Thermostat 518 or 519 |
| B1 = Modulating Condensing Boiler | T4 = Generic Digital Power-Stealing Thermostat |
| BP = Boiler Pump | T5 = Generic Bi-Metallic Strip Thermostat |
| PS = System Pump | V1 = 2-Wire Zone Valve |
| P1 = Zone 1 DHW Tank Pump | V2, V3 = 3-Wire Zone Valves (e.g. Taco 570) |
| T1 = WiFi Thermostat 561 or 562 | V4, V5 = 4-Wire Zone Valves |

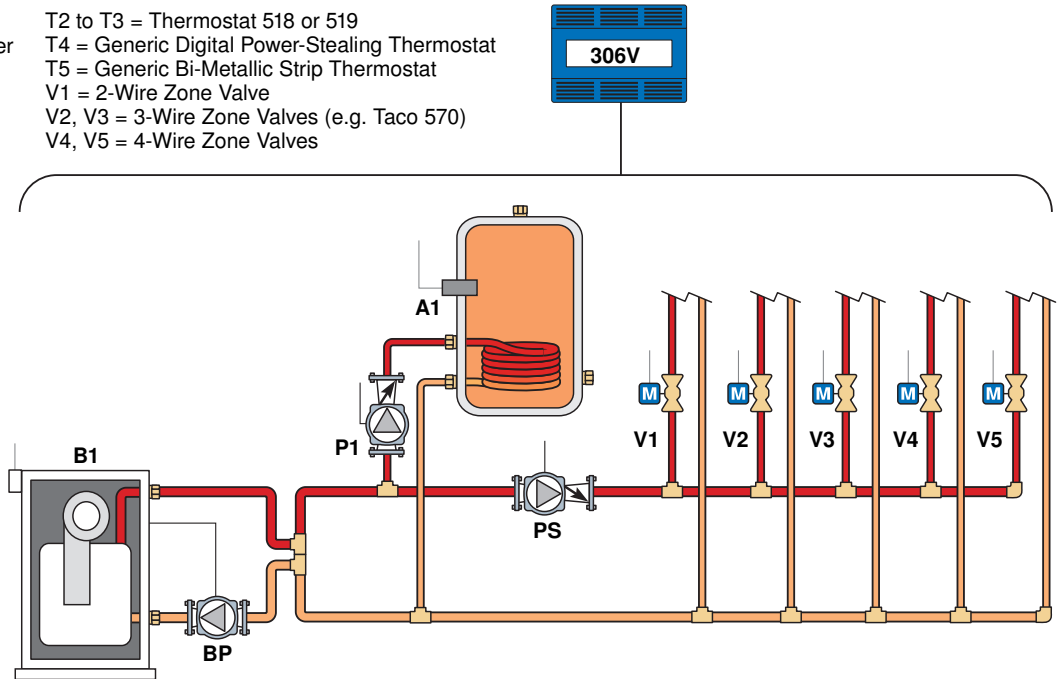

Electrical

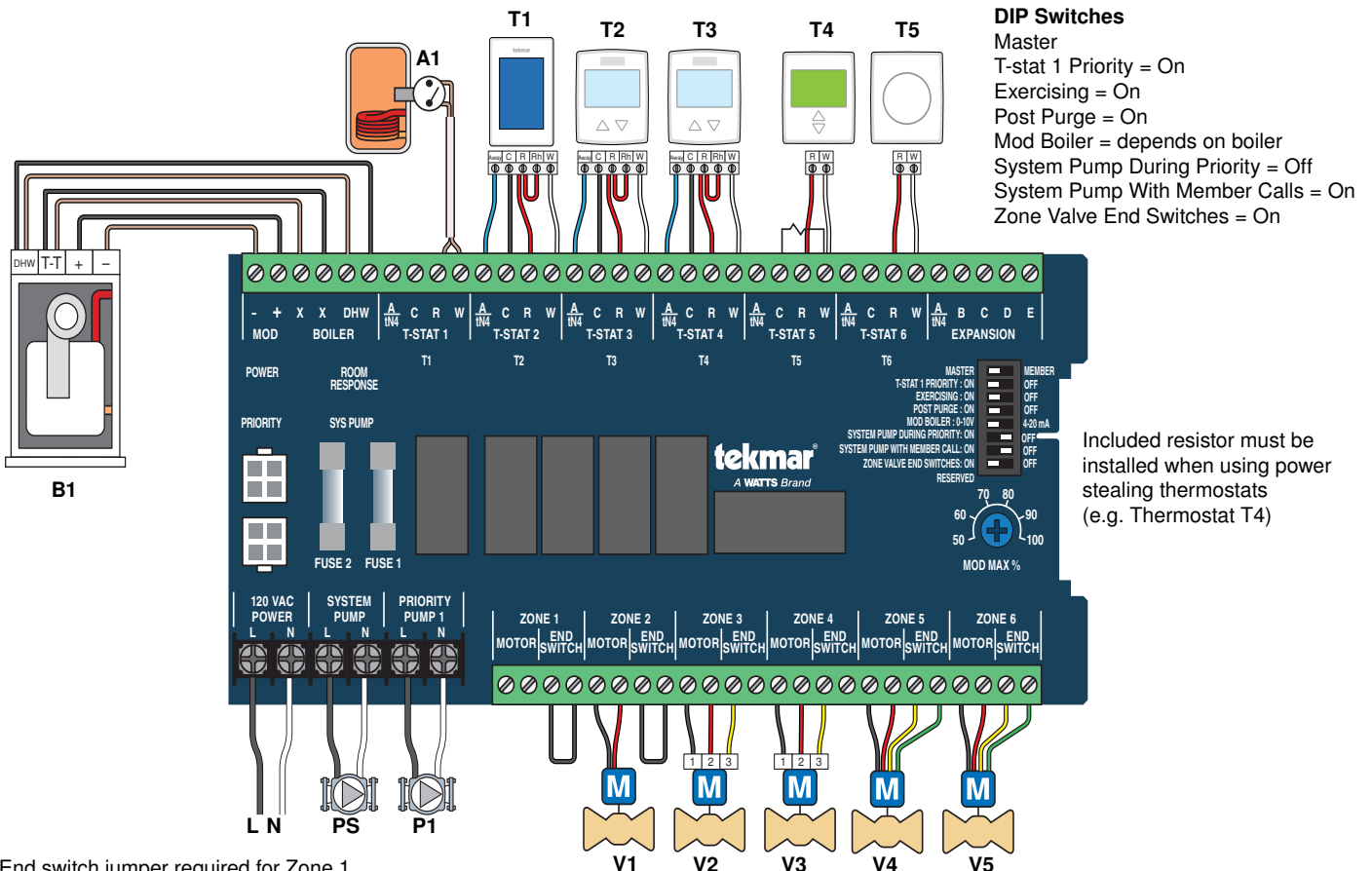

End switch jumper required for Zone 1 when using a pump and Zone Valve End Switch DIP = On

Application 306V-3

Two Zone Valve Control 306V operate eleven heating zones and a domestic hot water tank. When a thermostat calls for heat, the zone valve opens. The hot water tank is heated using a pump when the tank aquastat calls for heat. The master control operates the system pump and the boiler when there is a call for heat on either the master or member control.

Mechanical

Legend

A1 = DHW Tank Aquastat
 B1 = Modulating Condensing Boiler
 BP = Boiler Pump
 PS = System Pump

P1 = Zone 1 DHW Tank Pump
 T1 to T5 = WiFi Thermostat 561 or 562
 T6 to T9 = Thermostat 518 or 519

T10 = Generic Digital Power-Stealing Thermostat
 T11 = Generic Bi-Metallic Strip Thermostat
 V1 to V11 = 4-Wire Zone Valves

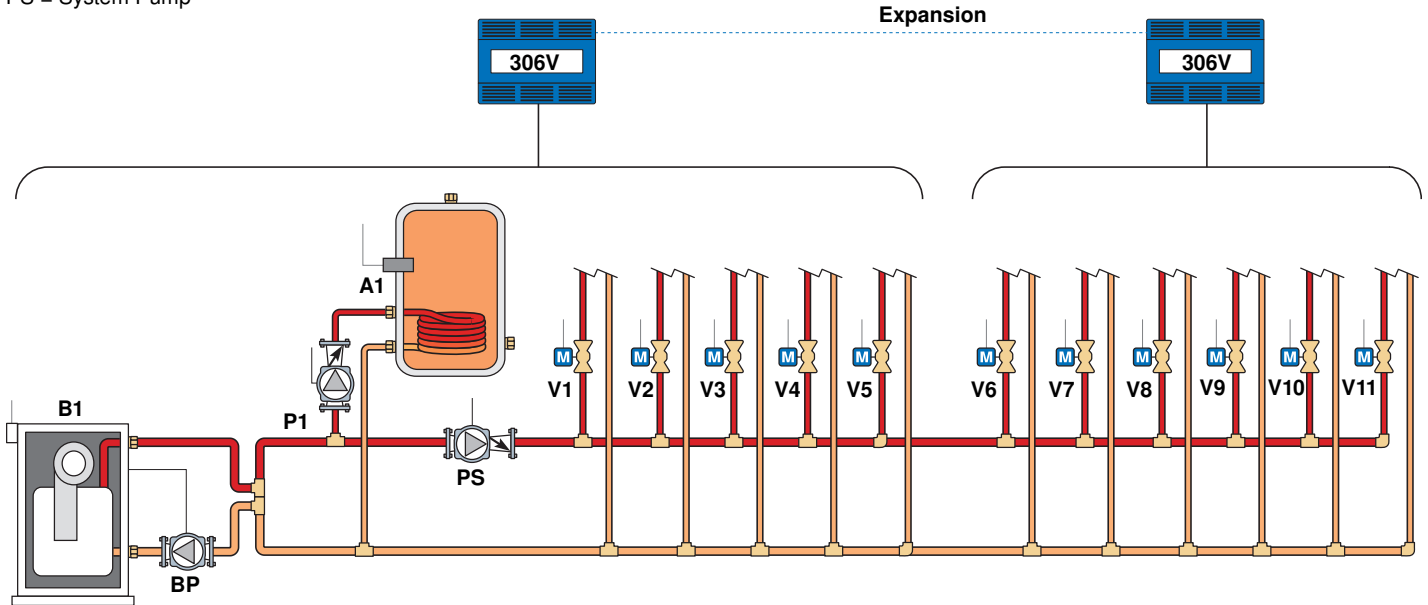

Electrical

End switch jumper required for Zone 1 when using a pump and Zone Valve End Switch DIP = On

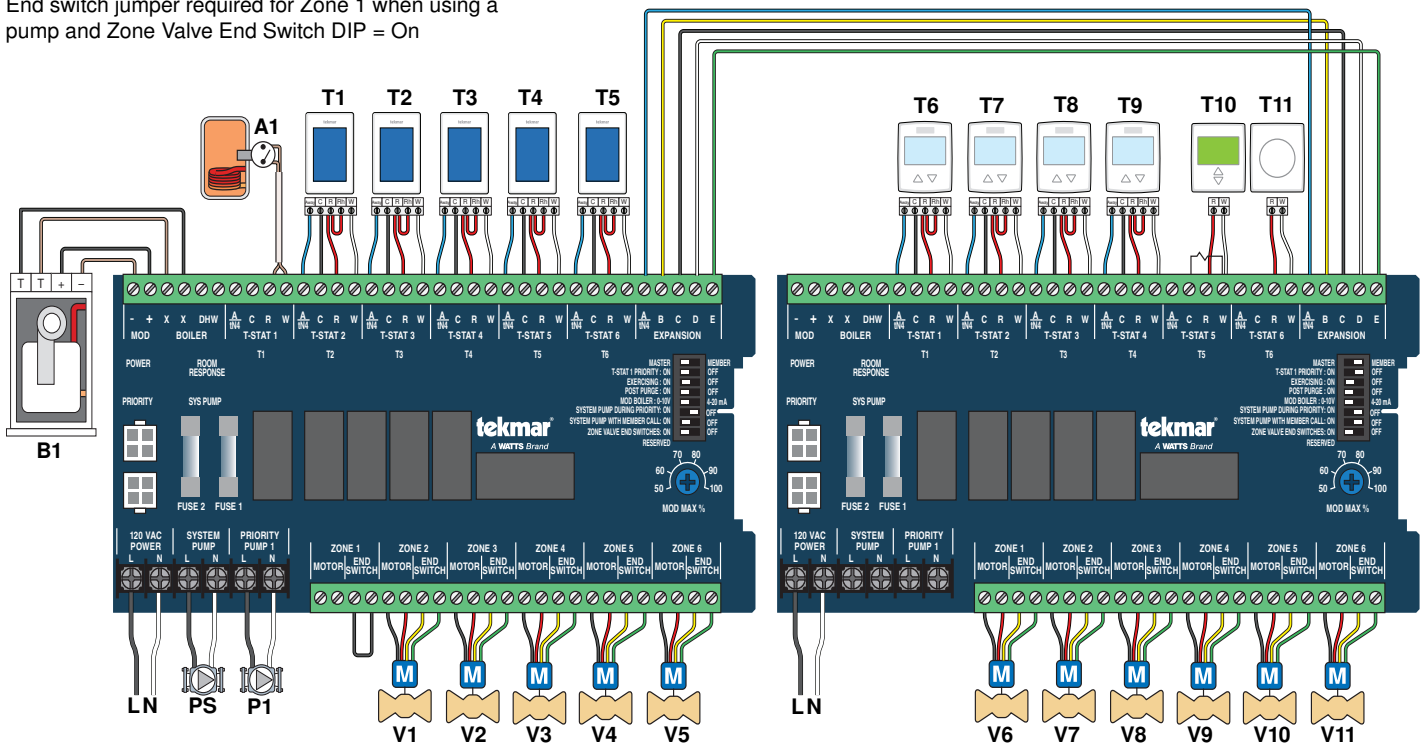

DIP Switches - Master

Master
 T-stat 1 Priority = On
 Exercising = On
 Post Purge = On
 Mod Boiler = depends on boiler
 System Pump During Priority = Off
 System Pump With Member Calls = On
 Zone Valve End Switches = On

DIP Switches - Member

Member
 T-stat 1 Priority = Off
 Exercising = On
 Post Purge = On
 Mod Boiler = depends on boiler
 System Pump During Priority = Off
 System Pump With Member Calls = Off
 Zone Valve End Switches = On

User Interface - Indicator LED

Power

- On when 115 V (ac) is applied.
- Off when power disconnected or transformer fuse is blown.

Priority

- On when zone 1 has priority over zones 2 to 6.

RoomResponse™

- On when modulating condensing boiler is operating below maximum setting.

System Pump

- On when zone valve end switches are closed (valve open).
- Off when zone valve end switches are open circuit (valves closed).

Sequence of Operation

Zone Operation

When a thermostat calls for heat by closing the R and W terminals:

- 24 V (ac) is applied to the corresponding zone valve.
- The corresponding zone indicator LED is turned on.

Boiler Operation

When a thermostat calls for heat by closing the R and W terminals:

- The boiler end switch XX is closed to fire the boiler.
- The RoomResponse™ 0-10 V (dc) or 4-20 mA signal is sent to a modulating-condensing boiler.

DHW Operation

Many modulating-condensing boilers have multiple temperature call inputs. Wire the DHW end switch to input recommended in the boiler's manual.

When a zone 1 calls for heat by closing the R and W terminals:

- The DHW end switch is closed to fire the boiler at the DHW temperature.
- The Mod Boiler output is changed to 10 V (dc) or 20 mA.

Master / Member DIP Switch

- Allows for unlimited expansion using additional Switching Relays and/or Zone Valve Controls.
- The Master Switching Relay is wired and operates the boiler.
- If using a single Switching Relay set to Master.
- When using multiple Switching Relays and/or Zone Valve Controls, set one control to Master and set all other controls to Member.

T-Stat 1 Priority DIP Switch

When T-Stat 1 is calling for heat by closing the R and W terminals:

- 115 V (ac) is applied to the Priority Pump 1.
- Zone 1 indicator LED is turned on.
- Priority indicator LED is turned on.
- Zones 2 to 6 zone valves and LEDs are turned off.
- Expansion Member controls shut off their zones.
- After 60 minutes of continuous zone 1 call for DHW heating, zones 2 to 6 are able to turn back on. This prevents building freeze up if the DHW tank aquastat fails in the closed position.
- A jumper wire must be installed on the zone 1 end switch if a pump is installed and the Zone Valve End Switches DIP switch is set on.

Zone 1 Call

- On when thermostat 1 calls for heat.
- Off when thermostat 1 stops calling for heat.

Zones 2 to 6 Call

- On when the corresponding thermostat calls for heat.
- Off during priority operation.
- Off when corresponding thermostat stops calling for heat.

Zones 1 to 6 Valve Open

- On when corresponding thermostat calls for heat and the zone valve is open (zone valve end switch closed).
- Off when zone valve closed (zone valve end switch open circuit).
- Off when corresponding thermostat stops calling for heat.

Exercising DIP Switch

ON: Each circulator pump is energized for 30 seconds every 72 hours.

OFF: Circulator pump exercising disabled.

Post Purge DIP Switch

ON: After thermostat 1 stops calling for heat, the zone 1 priority pump and zone valve remain on for 2 minutes to purge heat from the boiler to the zone.

OFF: Post purge disabled.

Mod Boiler DIP Switch

Select either 0-10 V (dc) or 4-20 mA signal to the modulating condensing boiler. Consult the boiler manual to determine the signal type. The DIP switch position does not matter if the modulating boiler output is not used.

System Pump During Priority DIP Switch

On: System pump operates when zone 1 calls for heat.

Off: System pump shuts off when zone 1 calls for heat. Typically set off when using a pump for heating a domestic hot water tank.

System Pump With Member Call DIP Switch

On: System pump on the master control runs when a zone on a member control calls for heat.

Off: System pump on the master control does not turn on when a zone on a member control calls for heat.

Zone Valve End Switches DIP Switch

On: System pump and boiler will not turn on until the zone valve end switch is closed. Select this option when using 3 or 4-wire zone valves.

Off: System pump and boiler turn on immediately when a thermostat calls for heat. Select this option when using 2-wire zone valves.

Fuses

- All fuses are T5A 250V slow blow.
- Fuse 1 and 2 correspond to the 24 V (ac) transformer power supply. If a fuse is blown, first check that the thermostat wiring is not shorted. Then replace the fuse.

Expansion Terminals

Connect the five wires of the expansion bus from the master to the member controls.

Terminal	Description
A/tN4	Away signal connecting tekmar thermostats
B	RoomResponse™ signal from member controls
C	Power common
D	Demand signal. 0 Vdc = demand. 2 Vdc = no demand
E	Priority signal. 0 Vdc = priority. 2 Vdc = no priority

RoomResponse™ Signal

The RoomResponse™ signal adjusts the temperature of a modulating condensing boiler that accepts a 0-10 V(dc) or 4-20 mA signal input. It works by continually adjusting boiler water temperatures to the lowest possible value to meet comfort without wasting energy. This is done by monitoring each thermostat's on and off time pattern and determines the ideal water temperature for each zone. The control then chooses the highest water temperature requirement of all the thermostats and provides a 0-10 V (dc) or 4-20 mA signal proportional to the boiler operating temperature. The RoomResponse™ signal is a DOE compliant method of controlling boiler temperature to building load. The RoomResponse™ signal is not available to on/off boilers.

Benefits of the RoomResponse™ signal include:

- Increase in boiler efficiency
- Reduction of room temperature swings
- Reduction in expansion noises from heating pipes

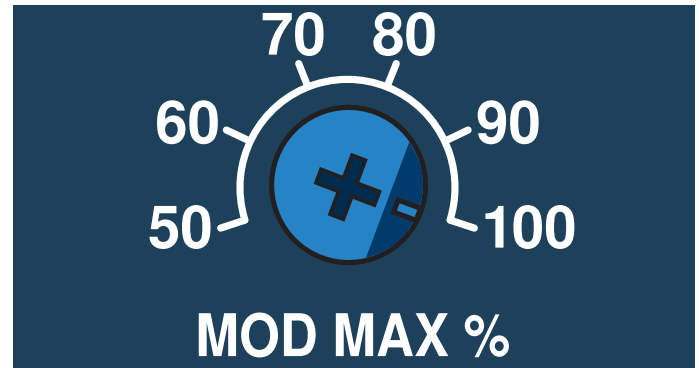

Mod Max % dial set to 100% in the illustration.

Mod Max % Dial

The upper limit of the 0-10 V (dc) or 4 -20 mA signal to the modulating condensing boiler can be set using the Mod Max % Dial. This sets the upper temperature limit for the boiler.

The dial is only applicable to controls set as the Master.

Mod Max %	Max Voltage	Max mA
50	5	12
60	6	13.6
70	7	15.2
80	8	16.8
90	9	18.4
100	10	20

Setting the Max Mod % Dial

Boiler Make/Model	Required Adapter (Supplied by boiler manufacturer)	0-10 V (dc) / 4-20 mA DIP Switch	Mod Max % Dial for Boiler Design Temperature			
			120°F	140°F	160°F	180°F
Aerco AM series	Not required	0-10 V	50%	65%	80%	100%
Bosch Greenstar	ICM Module	0-10 V	55%	70%	80%	100%
Buderus GB142, GB162	EM10 Module	0-10 V	50%	60%	75%	90%
Burnham® Alpine™*	Not required	4-20 mA	50%	70%	85%	100%
Camus® Modulating Microflame®	Not required	0-10 V	50%	60%	70%	85%
HTP Elite	Not required	0-10 V	50%	65%	80%	90%
IBC VFC and SL series*	Not required	0-10 V	65%	75%	85%	100%
Laars® Mascot LX	Not required	0-10 V	55%	70%	85%	100%
Laars® Mascot FT	Not required	0-10 V	50%	65%	80%	100%
Lochinvar® Knight™	Not required	0-10 V	55%	70%	85%	100%
Lochinvar® FTXL*	Not required	0-10 V	55%	70%	85%	100%
NTI Trinity Fire Tube and LX	Not required	4-20 mA	55%	65%	75%	90%
Peerless PureFire	PFA-1 Adapter	0-10 V	55%	65%	75%	90%
Raypak Xfyre, Xtherm, MVB, XPakFT	Not required	0-10 V	55%	65%	80%	90%
Riverside HeatStation*	Not required	0-10 V	50%	65%	85%	100%
Viessmann 100-W, WB1B	OpenTherm Module	0-10 V	55%	70%	85%	100%
Viessmann 200-W, B2HB and 300 CU3A	Not required	0-10 V	50%	60%	70%	80%
Weil-McLain® Evergreen*	Not required	0-10 V	50%	70%	85%	100%

* Requires changes to boiler's settings

Aerco AM Series

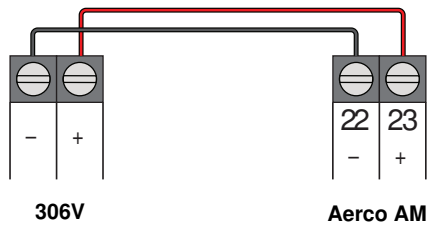

- No changes to the boiler are required.

Camus Modulating MicoFlame

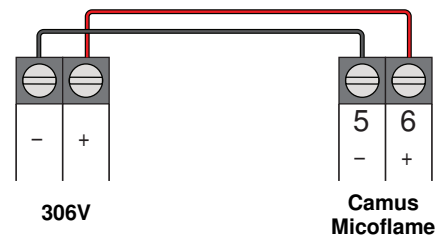

- Change control to mode 6 in the control parameters.

Bosch Greenstar



- Install the Bosch ICM as per the directions.
- Set ICM jumper to the left position to enable system supply water temperature (VT) mode.

Heat Transfer Products Elite

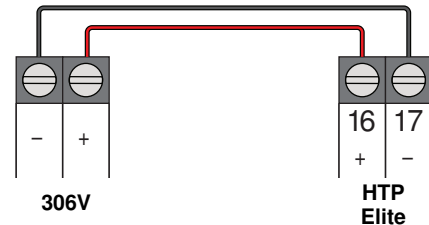

- Move jumper on connection board from A to B.
- Set function 17 to temperature.

Buderus GB142 and GB162

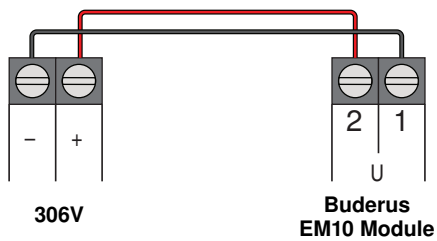

- Install the Buderus EM10 module as per the directions.
- Do NOT install the jumper between U terminals 1 and 3 on the EM10 module.

IBC VFC and SL Series

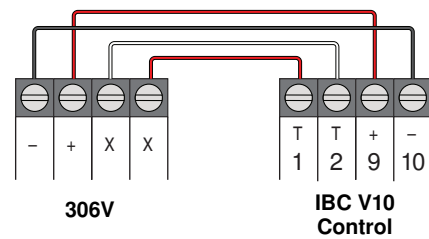

On the V10 controller:

- Set Load 1 to External Control
- Change "Max Control @ 9.5 Vdc" to 190°F (88°C)
- Change "Min Control @ 2.1 Vdc" to 32°F (0°C)

Burnham Alpine

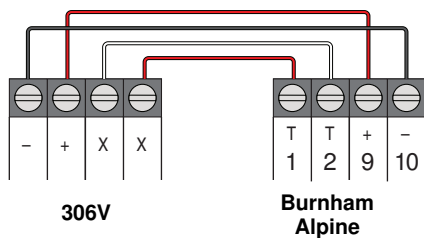

- Change Parameter 9 Remote 4-20 mA to Setpoint Source.
- Change "Energy Management" setting "Central Heat Modulation Source" to 4-20 mA.
- Change "Energy Management" setting "Central Heat 4-20 mA Setup, 4 mA Water Temperature" to 80°F (26.5°C).

Laars Mascot LX

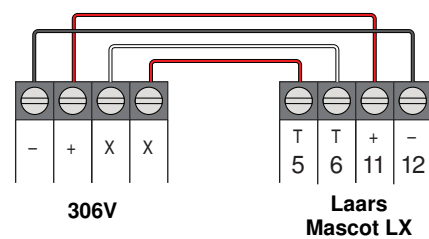

- Change Installer Parameter 25 "0-10V to Power" to Disabled.
- Change Installer Parameter 26 "0-10V to outlet setpoint" to Disabled.

Laars Mascot FT



- No changes to the boiler are required.

Lochinvar Knight

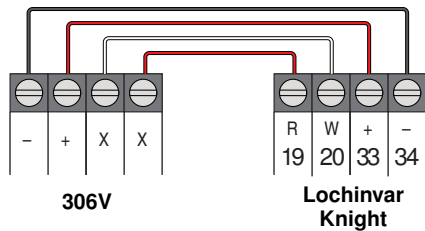

- Set BMS Type to Setpoint. This is the factory default setting.

Lochinvar FTXL

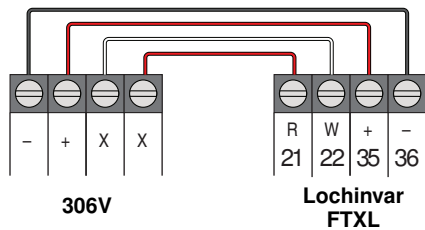

- Set BMS parameter to ACTIVE.
- Set BMS Type to SETPOINT.

NTI Trinity LX

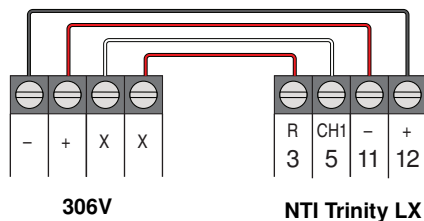

- Enter boiler password.
- Set Parameter "Setpoint source" to 4-20mA

NTI Trinity FireTube

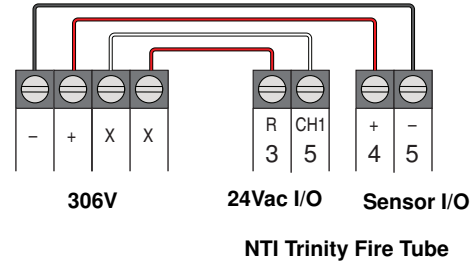

- Enter boiler password.
- Set Parameter "Setpoint source" to 4-20mA

Peerless Pinnacle PF-200, 210, 300, 399

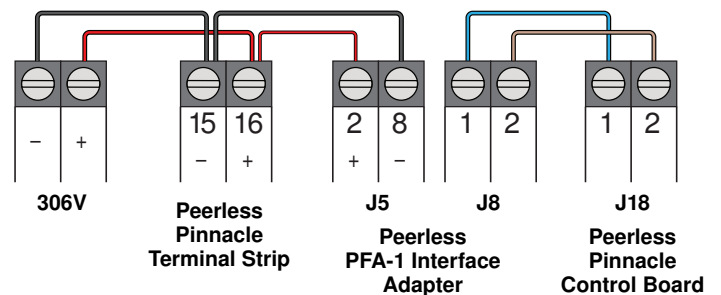

- Install the Peerless PFA-1 Interface Adapter
- On the boiler display, change Central Heating Mode to 4 for 0-10 VDC Input to Modulate Setpoint

Riverside HeatStation

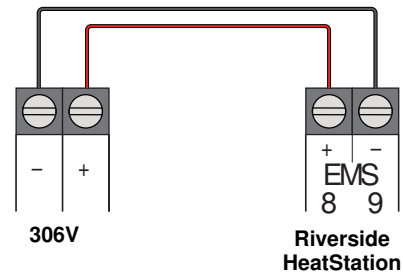

- Set boiler PIM DIP switch 2 to Off.
- Set boiler PIM DIP switch 5 to On.
- Set boiler PIM DIP switch 6 to Off.
- Set APP parameter to EMS
- Set SIGNAL parameter to 0-10Vdc
- Set SETP LO to 70°F
- Set SETP HI to 180°F

Raypak MVB and XTherm

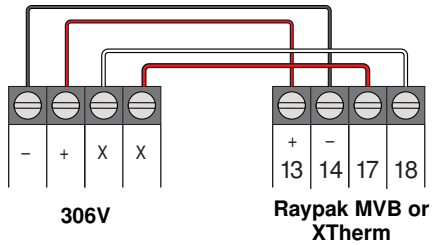

- Set boiler PIM DIP switch 2 to Down.
- Set boiler PIM DIP switch 5 to Up.

Raypak XFyre and XPakFT

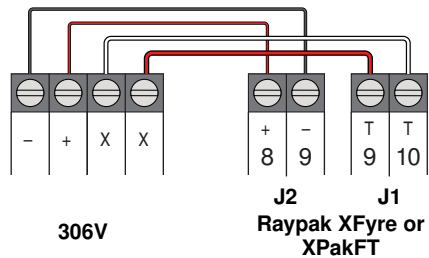

- Set boiler PIM DIP switch 2 to Down.
- Set boiler PIM DIP switch 5 to Up.

Viessmann Vitodens 100-W, WB1B

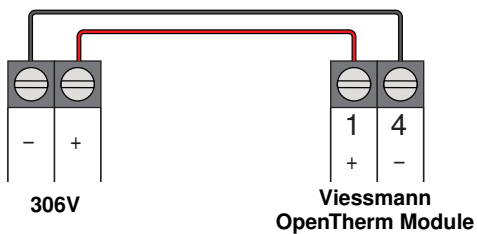

- Install the OpenTherm Module as per the boiler manufacturer's instructions.

Viessmann Vitodens 200-W, B2HP and Vitocrossal 300 CU3A

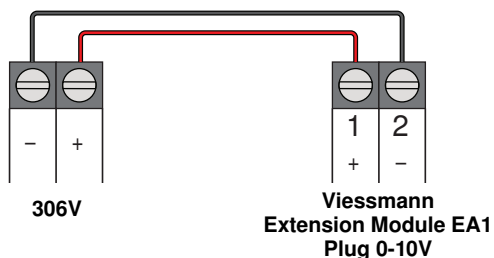

Weil-McLain Evergreen

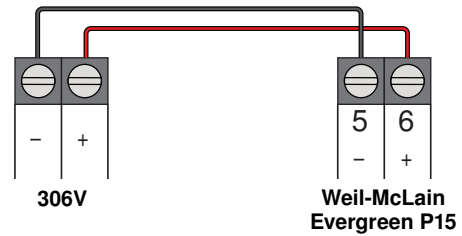

- Use Local Priority 1 for DHW tank heating.
- Use Local Priority 2 for the RoomResponse™ signal.
- Set Local Priority 2 Supply Min to 60°F.
- Set Local Priority 2 Supply Max to 180°F.
- Set Local Priority 2 Volts For Min to 2 V.
- Set Local Priority 2 Volts For Max to 10 V.

Technical Data

Zone Valve Control 306V Six Zones with Priority	
Literature	306V_C, 306V_D, 306V_J
Control	Microprocessor control. This is not a safety (limit) control.
Packaged weight	6.0 lb. (2750 g)
Dimensions	8-3/16" H x 10-11/16" W x 2-3/8" D (208 x 271 x 60 mm)
Enclosure	Cover: ABS plastic, Base: galvanized steel, NEMA type 1
Approvals	CSA C US
Ambient conditions	32 to 122°F (0 to 50°C), ≤ 90% RH non-condensing
Power supply	115 V (ac) ±10%, 60 Hz, 11 A
Transformer	80 VA
Control load	7 VA
Fuses	T5A 250 V slow blow, two spare fuses included
Zone valve outputs	24 V (ac), 2 A max each, 73 VA total
Zone valve end switch	24 V (ac)
System pump	230V (ac), 5 A, 1/3 hp
Boiler XX end switch	24 V (ac), 5 A
DHW end switch	24 V (ac), 5 A
Mod boiler output	0-10 V (dc) 500 Ω min impedance / 4-20 mA 1 kΩ max impedance

Limited Warranty and Product Return Procedure

Limited Warranty *The liability of tekmar under this warranty is limited. The Purchaser, by taking receipt of any tekmar product ("Product"), acknowledges the terms of the Limited Warranty in effect at the time of such Product sale and acknowledges that it has read and understands same.*

The tekmar Limited Warranty to the Purchaser on the Products sold hereunder is a manufacturer's pass-through warranty which the Purchaser is authorized to pass through to its customers. Under the Limited Warranty, each tekmar Product is warranted against defects in workmanship and materials if the Product is installed and used in compliance with tekmar's instructions, ordinary wear and tear excepted. The pass-through warranty period is for a period of twenty-four (24) months from the production date if the Product is not installed during that period, or twelve (12) months from the documented date of installation if installed within twenty-four (24) months from the production date.

The liability of tekmar under the Limited Warranty shall be limited to, at tekmar's sole discretion: the cost of parts and labor provided by tekmar to repair defects in materials and / or workmanship of the defective product; or to the exchange of the defective product for a warranty replacement product; or to the granting of credit limited to the original cost of the defective product, and such repair, exchange or credit shall be the sole remedy available from tekmar, and, without limiting the foregoing in any way, tekmar is not responsible, in contract, tort or strict product liability, for any other losses, costs, expenses, inconveniences, or damages, whether direct, indirect, special, secondary, incidental or consequential, arising from ownership or use of the product, or from defects in workmanship or materials, including any liability for fundamental breach of contract.

The pass-through Limited Warranty applies only to those defective Products returned to tekmar during the warranty period. This Limited Warranty does not cover the cost of the parts or labor to remove or transport the defective Product, or to reinstall the repaired or replacement Product, all such costs and expenses being subject to Purchaser's agreement and warranty with its customers.

Any representations or warranties about the Products made by Purchaser to its customers which are different from or in excess of the tekmar Limited Warranty are the Purchaser's sole responsibility and obligation. Purchaser shall indemnify and hold

tekmar harmless from and against any and all claims, liabilities and damages of any kind or nature which arise out of or are related to any such representations or warranties by Purchaser to its customers.

The pass-through Limited Warranty does not apply if the returned Product has been damaged by negligence by persons other than tekmar, accident, fire, Act of God, abuse or misuse; or has been damaged by modifications, alterations or attachments made subsequent to purchase which have not been authorized by tekmar; or if the Product was not installed in compliance with tekmar's instructions and / or the local codes and ordinances; or if due to defective installation of the Product; or if the Product was not used in compliance with tekmar's instructions.

THIS WARRANTY IS IN LIEU OF ALL OTHER WARRANTIES, EXPRESS OR IMPLIED, WHICH THE GOVERNING LAW ALLOWS PARTIES TO CONTRACTUALLY EXCLUDE, INCLUDING, WITHOUT LIMITATION, IMPLIED WARRANTIES OF MERCHANTABILITY AND FITNESS FOR A PARTICULAR PURPOSE, DURABILITY OR DESCRIPTION OF THE PRODUCT, ITS NON-INFRINGEMENT OF ANY RELEVANT PATENTS OR TRADEMARKS, AND ITS COMPLIANCE WITH OR NON-VIOLATION OF ANY APPLICABLE ENVIRONMENTAL, HEALTH OR SAFETY LEGISLATION; THE TERM OF ANY OTHER WARRANTY NOT HEREBY CONTRACTUALLY EXCLUDED IS LIMITED SUCH THAT IT SHALL NOT EXTEND BEYOND TWENTY-FOUR (24) MONTHS FROM THE PRODUCTION DATE, TO THE EXTENT THAT SUCH LIMITATION IS ALLOWED BY THE GOVERNING LAW.

Product Warranty Return Procedure All Products that are believed to have defects in workmanship or materials must be returned, together with a written description of the defect, to the tekmar Representative assigned to the territory in which such Product is located. If tekmar receives an inquiry from someone other than a tekmar Representative, including an inquiry from Purchaser (if not a tekmar Representative) or Purchaser's customers, regarding a potential warranty claim, tekmar's sole obligation shall be to provide the address and other contact information regarding the appropriate Representative.

WARNING: This product contains chemicals known to the State of California to cause cancer and birth defects or other reproductive harm.
For more information: Watts.com/prop65



A WATTS Brand

All specifications are subject to change without notice

Tel: (250) 545-7749 • Fax: (250) 984-0815
 tekmarControls.com