



# 00e™ series VT2218 Instruction Sheet

102-510

Use for pumps with  
date code TBD  
or after.

## Delta-T Variable Speed, ECM High-Efficiency Circulator

SUPERSEDES: NEW

EFFECTIVE: June 14, 2016

Plant ID No. 001-4267

### DESCRIPTION:

The 00e™ series VT2218 circulator is a temperature sensing, self-adjusting, variable speed wet rotor circulator with an ECM, permanent magnet motor. Operating modes include Delta-T, constant speed, set point heat, set point cool, and boiler protection. Its high efficiency motor reduces power consumption by up to 85% compared to equivalent AC permanent split capacitor circulators.

### APPLICATION:

- Maximum operating pressure: 125 psi (862 kPa)
- Minimum water temperature: 36°F (2°C)
- Maximum water temperature: 230°F (110°C)
- Electrical specifications:
  - Voltage: 110-120V, 50/60 Hz, single phase
  - Maximum operating power: 58W
  - Maximum amp rating: 0.67
- Equipped with a cast iron casing and should be used for closed loop systems only.
- Taco circulator pumps are for indoor use only – employer uniquement à l'intérieur.
- Acceptable for use with water or maximum of 50% water/glycol solution.



For more information, visit  
[www.TacoComfort.com](http://www.TacoComfort.com)

### FEATURES:

- 5 operating modes:
  - Delta-T - variable speed, maintains constant  $\Delta T$ , provides exact GPM flow required
  - Constant Speed - 4 fixed speeds, maintains constant flow for zoning
  - Set Point Heat - variable speed with boiler protection option, decreases speed on temperature rise
  - Set Point Cool - variable speed, increases speed on temperature rise
  - Boiler Protection - protects boiler from low return temperature and flue gas condensation
- Illuminated LCD displays:
  - Operating mode, speed or temperature setting, watts, gpm, supply temperature, return temperature, and error code diagnostics.
- Use with a Taco ZVC Zone Valve Control or SR Switching Relay for ON/OFF operation.
- Integral Flow Check (IFC) is included in carton. Simply press into discharge flange if required.
- Nut capture feature on flanges for easier fit up.
- Whisper quiet operation.
- BIO Barrier® protects the pump from system contaminants.
- SureStart automatic unblocking mode.
- Optional, 2-way flange model available to reduce SKU's and provide universal fit-up to any flange position.



### INSTALLATION:

**WARNING: Do not use in swimming pool or spa areas. Pump has not been investigated for these applications.**  
**AVERTISSEMENT: Ne pas utiliser dans une piscine ou un spa. La pompe n'a pas été étudiée pour ces applications.**

**CAUTION: The addition of petroleum based fluids or certain chemical additives to systems using TACO equipment voids the warranty. Consult factory for fluid compatibility.**  
**ATTENTION: L'ajout de liquides à base de pétrole ou de certains additifs chimiques à des systèmes utilisant un équipement TACO annule la garantie. Consultez le fabricant pour connaître la compatibilité de liquides.**

**CAUTION: Installations at elevations over 5000 feet must have higher fill pressure of 20 psi minimum to prevent pump cavitation and flashing. Premature failure may result. Adjust expansion tank pressure to equal fill pressure. A larger size expansion tank may be required.**  
**ATTENTION: Des installations à des altitudes de plus de 1600 mètres doivent présenter une pression de remplissage plus élevée de 20 psi au minimum afin d'éviter toute cavitation ou flashing de la pompe. Une défaillance prématurée peut en résulter. Réglez la pression du réservoir d'expansion de façon qu'elle soit égale à la pression de remplissage. Un réservoir d'expansion d'une taille supérieure peut être nécessaire.**

**FIGURE 1:**

**PREFERRED PIPING FOR CIRCULATORS ON BOILER SUPPLY**

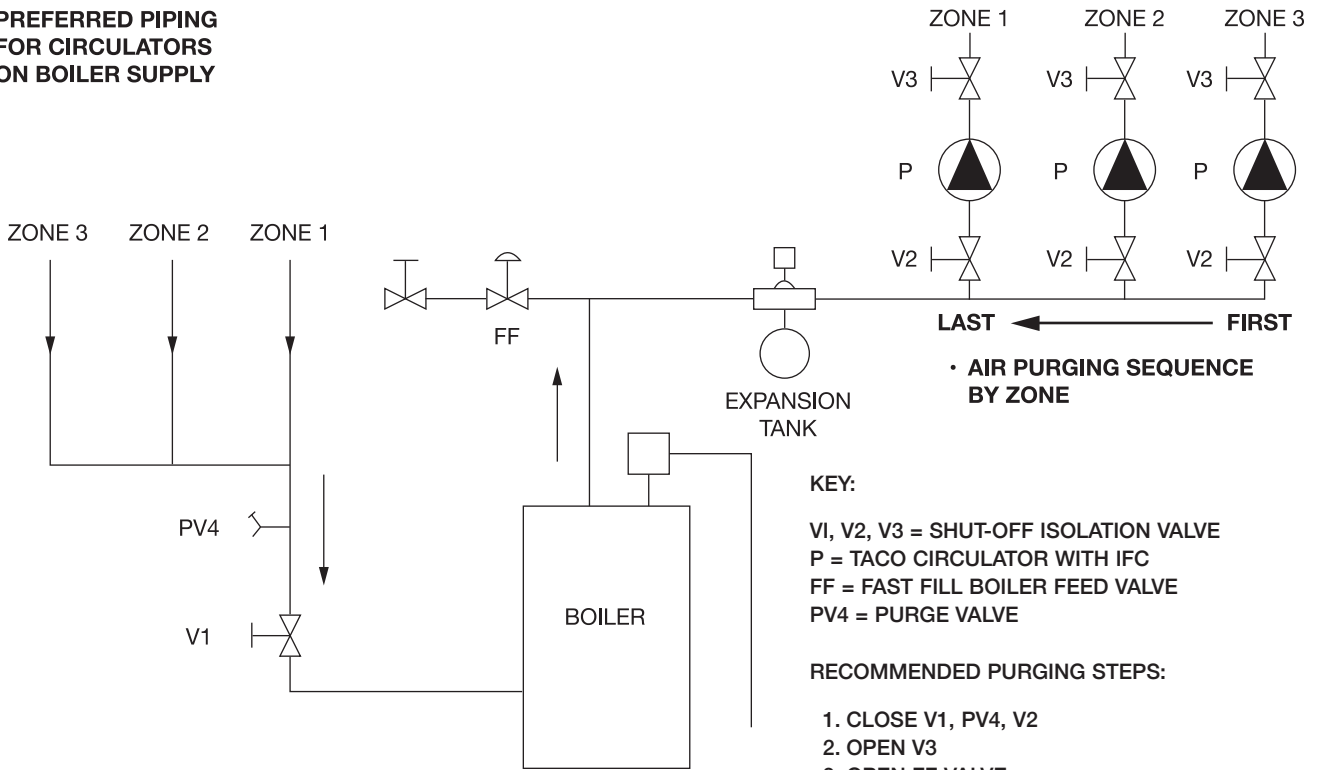

- RECOMMENDED PURGING STEPS:**
1. CLOSE V1, PV4, V2
  2. OPEN V3
  3. OPEN FF VALVE
  4. OPEN V2, PV4, TO PURGE LAST ZONE FIRST (ZONE 3)
  5. CLOSE FF VALVE
  6. CLOSE V2, PV4
  7. REPEAT STEPS 1 TO 6 FOR EACH ADDITIONAL ZONE, PURGE ZONE 1 LAST
  8. OPEN V1 WHEN ALL ZONES ARE PURGED
  9. ADJUST SYSTEM TO DESIRED OPERATING FILL PRESSURE IF REQUIRED

**ALTERNATE PIPING FOR CIRCULATORS ON BOILER RETURN**

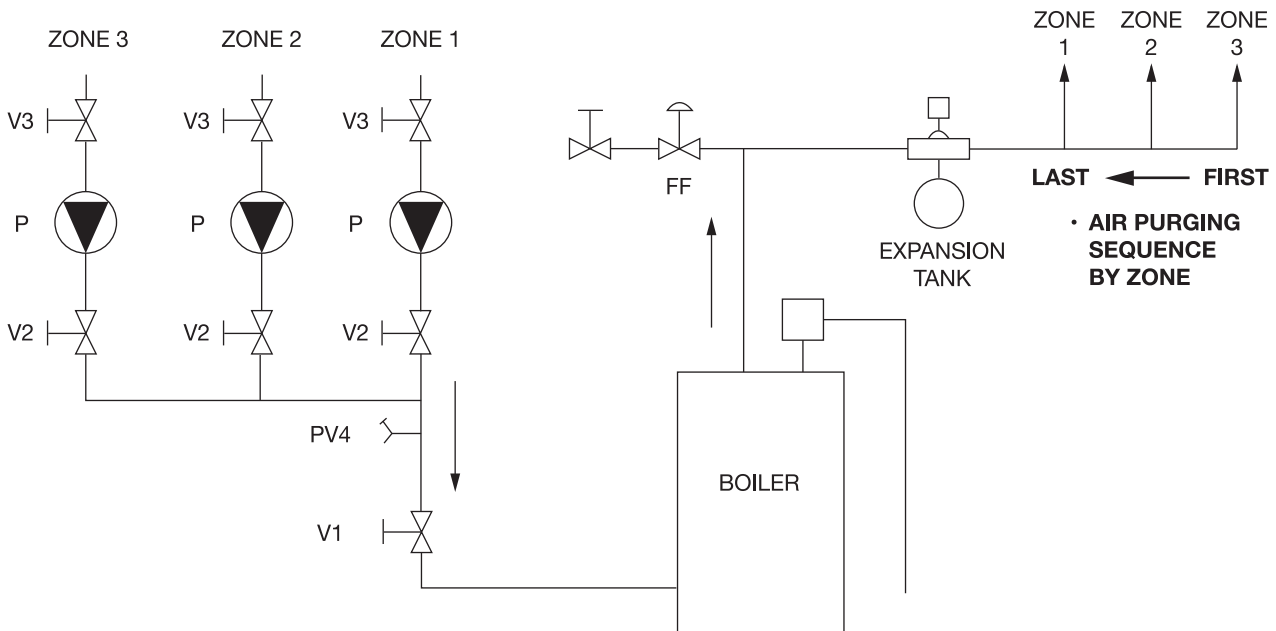

**FIGURE 2:**

**PREFERRED PIPING FOR ZONE VALVES ON BOILER SUPPLY**

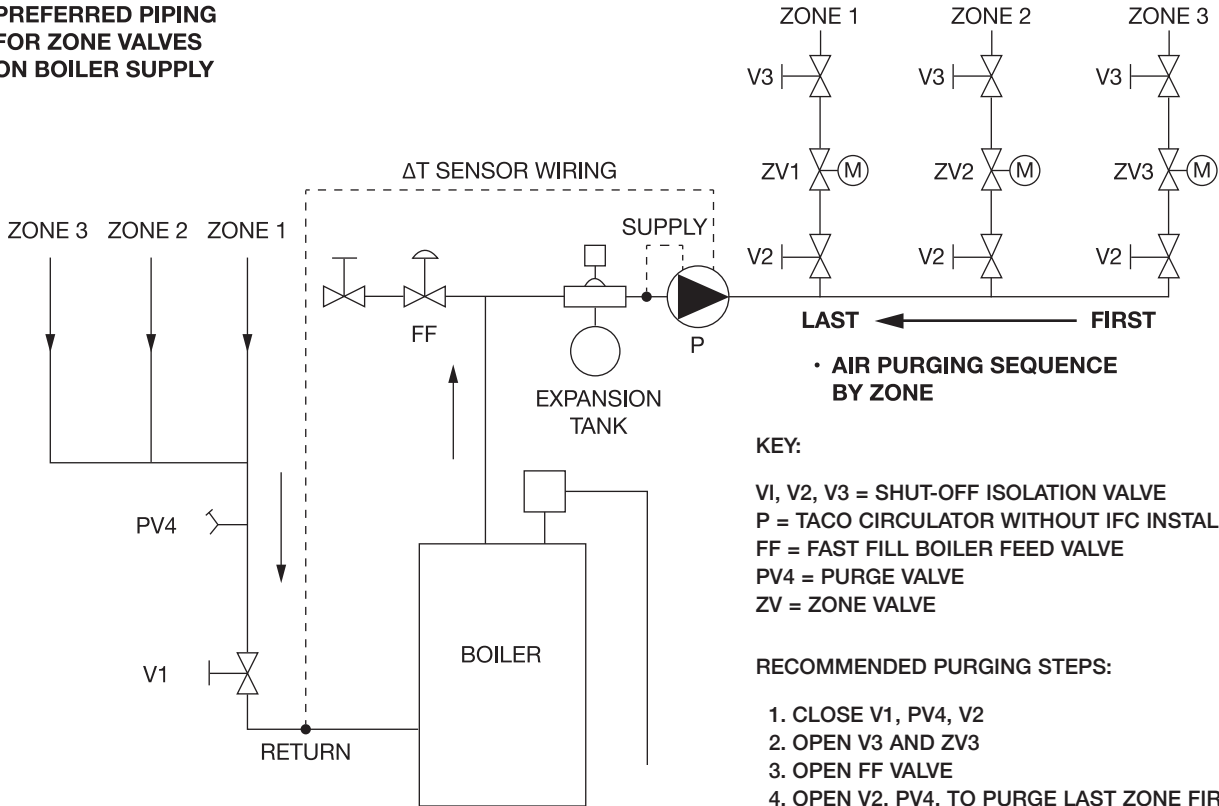

**• AIR PURGING SEQUENCE BY ZONE**

**KEY:**

- V1, V2, V3 = SHUT-OFF ISOLATION VALVE
- P = TACO CIRCULATOR WITHOUT IFC INSTALLED
- FF = FAST FILL BOILER FEED VALVE
- PV4 = PURGE VALVE
- ZV = ZONE VALVE

**RECOMMENDED PURGING STEPS:**

1. CLOSE V1, PV4, V2
2. OPEN V3 AND ZV3
3. OPEN FF VALVE
4. OPEN V2, PV4, TO PURGE LAST ZONE FIRST (ZONE 3)
5. CLOSE FF VALVE
6. CLOSE V2, PV4
7. REPEAT STEPS 1 TO 6 FOR EACH ADDITIONAL ZONE, PURGE ZONE 1 LAST
8. OPEN V1 WHEN ALL ZONES ARE PURGED
9. ADJUST SYSTEM TO DESIRED OPERATING FILL PRESSURE IF REQUIRED
10. MOVE ALL ZV TO CLOSED/AUTOMATIC POSITION

**ALTERNATE PIPING FOR ZONE VALVES ON BOILER RETURN**

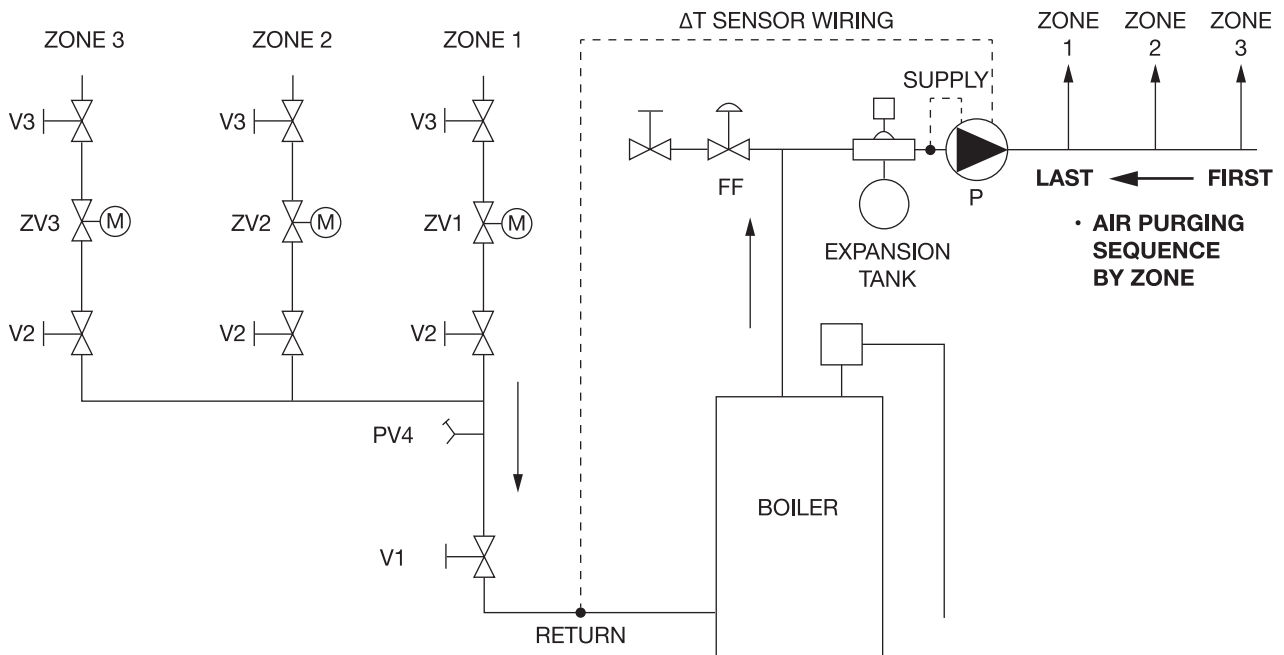

**• AIR PURGING SEQUENCE BY ZONE**

**Typical Variable Speed Applications:**

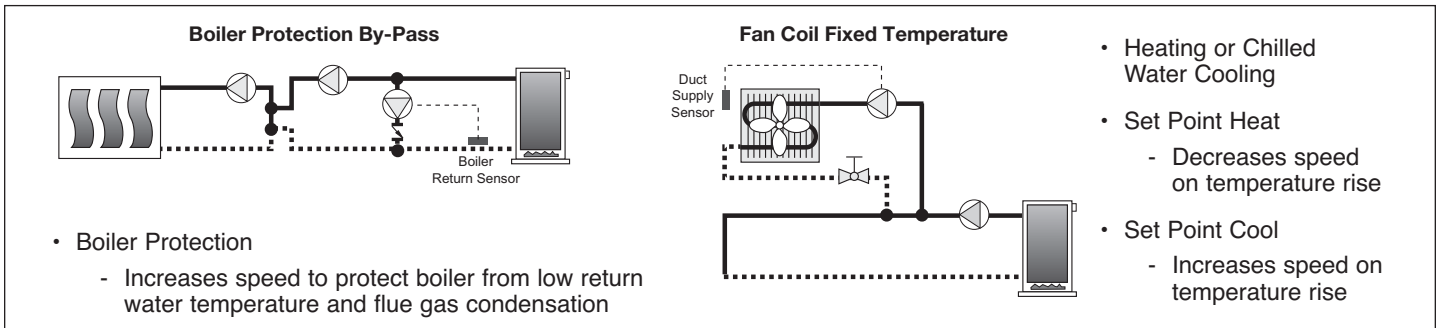
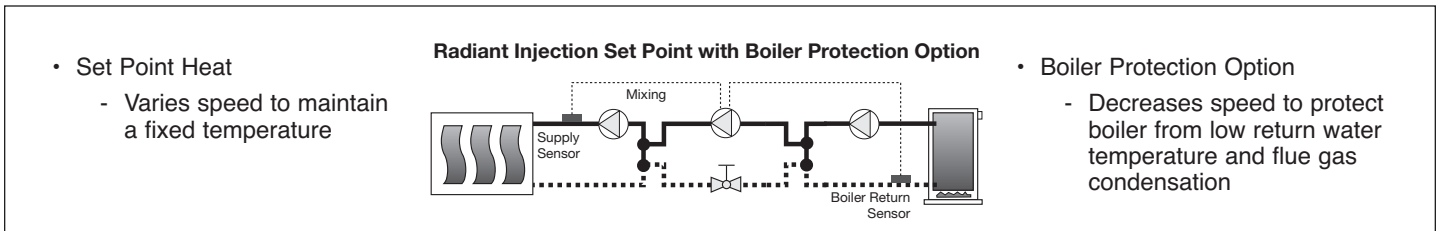
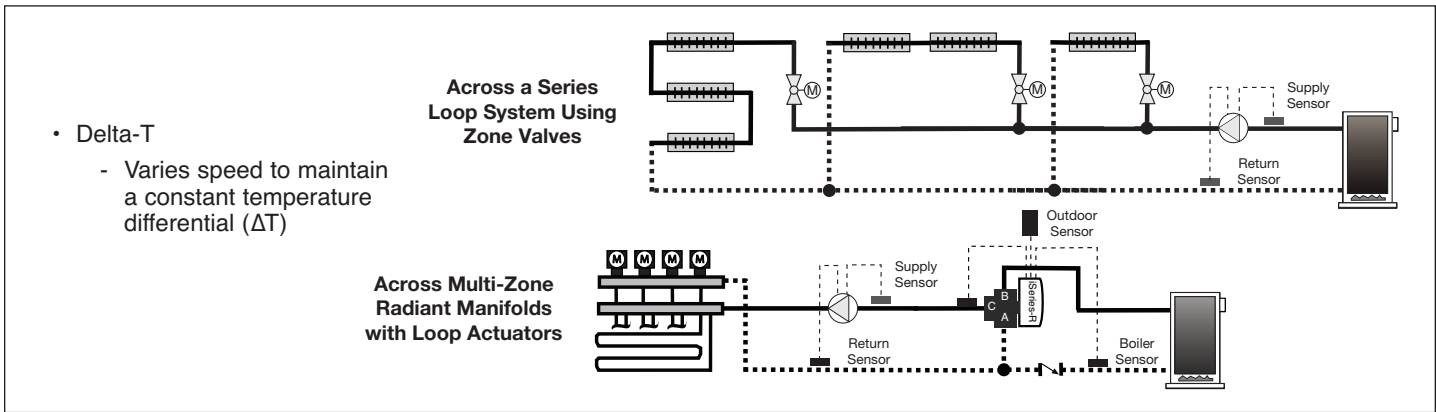

**1. Location:**

The circulator can be installed on the supply or return side of the boiler but for best system performance, it should always pump away from the expansion tank. See piping diagrams in Figures No.1 and No. 2.

**Integral Flow Check (IFC®) option** - An IFC® is included in the carton. If required, press IFC into machined discharge port with plunger and o-ring facing in, until it snaps into place. Before installing, press IFC plunger to be sure it moves freely. See diagram below.

**2. Mounting position:**

Circulator must be mounted with the motor in the horizontal position. See diagrams below for acceptable motor mounting orientations.

**CAUTION: Do not use flat rubber gaskets. Only use O-ring gaskets provided or leaks may result. Warranty will be void.**

**ACCEPTABLE MOTOR MOUNTING POSITIONS**

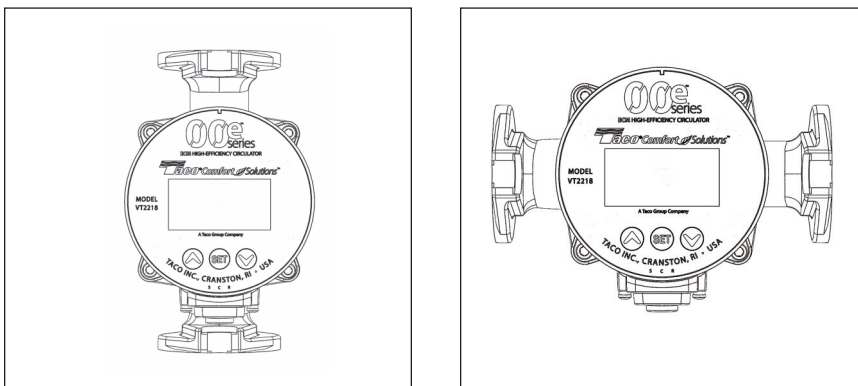

Position electrical knockout at 6 o'clock position for best programming and LCD viewing orientation. Casing may be rotated to change flow direction.

**CASING ROTATION**

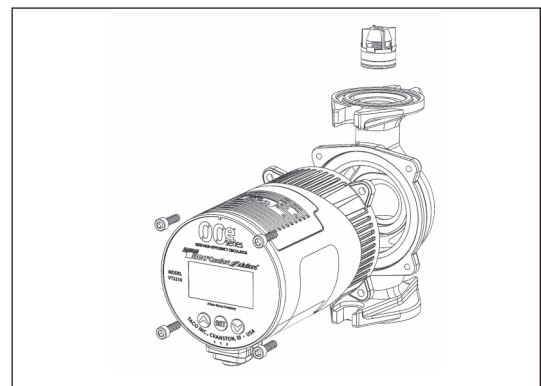

To rotate the casing, remove the 4 motor screws and spin the casing to the desired flow direction. Reattach the 4 screws (5/32" allen wrench required). Be sure body gasket is seated evenly to prevent leakage. Tighten motor screws to 34-42 in-lbs torque.

**CAUTION:** To reduce the possibility of noise transmission, be sure to add vibration dampeners to piping when mounting circulator to wall or floor joists.

**ATTENTION:** Pour réduire la possibilité de transmission de bruit, veillez à ajouter des amortisseurs de vibration à la tuyauterie lors du montage du circulateur sur des chevêtres de mur ou de plancher.

### 3. Fill the system with tap water or a maximum of 50% propylene-glycol and water solution:

The system must be filled before operating the circulator. The bearings are water lubricated and should not be allowed to operate dry. Filling the system will result in immediate lubrication of the bearings. It is always good practice to flush a new system of foreign matter before starting the circulator.

**WARNING:** Risk of electric shock. To reduce the risk of electric shock, be certain that it is connected only to a properly grounded, grounding-type receptacle. Follow all local electrical and plumbing codes.

**AVERTISSEMENT:** Risque de choc électrique. Pour réduire le risque de choc électrique, veillez à ce qu'elle soit raccordée uniquement à un réceptacle de type mise à la terre proprement mis à la terre. Respectez tous les codes de plomberie et électriques locaux.

**WARNING:** Use supply wires suitable for 90°C,

**AVERTISSEMENT:** Employer des fils d'alimentation adéquats pour 90°C.

### 4. Wiring the circulator:

- Disconnect AC power supply. Remove terminal box cover. Thread a wiring connector into npt knockout. **Note:** To install an angle connector removal of sensor cap may be required for clearance. Connect hot wire to black lead and neutral wire to white lead. Connect ground wire to Green Ground screw. Replace terminal box cover.

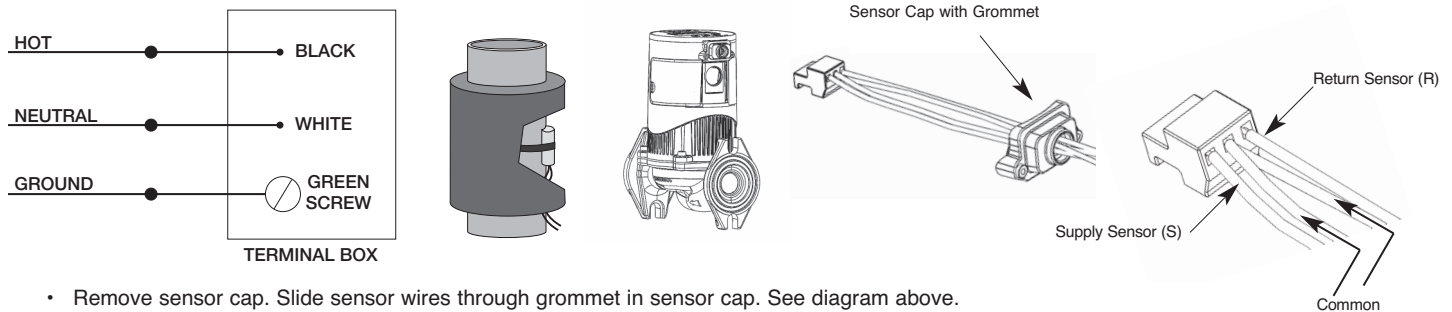

- Remove sensor cap. Slide sensor wires through grommet in sensor cap. See diagram above.
- Attach sensor wires provided as shown:
  - Delta-T mode uses supply and return (S + R).
  - Set Point mode uses supply (S) for system sensor and return (R) for boiler protection return sensor.
- Attach sensors to supply and return piping using the zip-ties provided. See diagram above.
  - In Delta-T mode, place sensors on system supply and return.
  - In Set Point Heat mode, place supply sensor on system loop supply. If boiler protection option is used, place return sensor on boiler return.
- Insulate pipe around sensors as shown.

### 5. Start the circulator:

**Note:** When power is applied to the circulator it will go through a 10 second diagnostic delay before starting. The LCD will illuminate for the first 5 minutes of a run cycle. Press any of the programming buttons to re-illuminate the LCD.

When air purging the system, it is recommended to run the circulator at full speed long enough to remove all remaining air from the bearing chamber. This is especially important when installing the circulator in the off-season.

**CAUTION:** Never run the circulator dry or permanent damage may result.

**ATTENTION:** Ne laissez jamais le circulateur tourner à sec, des dommages permanents peuvent en résulter.

#### Full Speed Over-Ride Feature:

To run the pump at full speed during the fast fill, start-up and purge process, press and hold the **UP** button for 3 seconds until "Full Speed Override" appears on the LCD display. To return to the programmed, normal operating mode, press the **SET** button.

**"SureStart" Feature:** In rare cases where a locked rotor may occur, the SureStart feature will activate automatically and rapidly vibrate to unblock the rotor and continue normal operation.

### 6. Programming your VT2218 circulator:

**Note:** The VT2218 is factory-programmed for **Delta-T** operating mode with a **20°F** temperature differential setting. If this is your desired operating mode and Delta-T setting, no programming changes are required.

#### The VT2218 has 5 Operating Modes:

- **Delta-T** - Varies speed to maintain a fixed temperature differential (factory pre-set mode).
- **Constant Speed** - 4 fixed speeds (see pump curves on previous page to select desired performance).
- **Set Point Heat** - Increases speed to increase temperature (includes Boiler Protection option).
- **Set Point Cool** - Increases speed to lower temperature.
- **Boiler Protection** - Varies speed to maintain minimum boiler return temperature.

### To change operating mode and settings:

- Press and hold the **SET** button for 3 seconds until the operating mode on the LCD begins to flash.
- Use the **UP** or **DOWN** buttons to scroll through the 5 operating mode options. When the desired mode flashes on the LCD, press the **SET** button. The LCD will begin to flash either temperature or speed setting options, whichever applies.
- Use the **UP** button to increase temperature or speed settings. Use the **DOWN** button to decrease temperature or speed settings. When the desired setting flashes, press the **SET** button.
- Your programming is complete and the operating mode and setting will appear on the LCD screen.

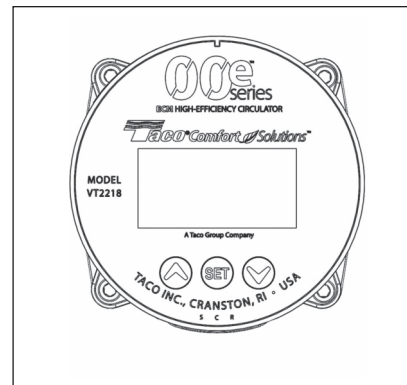

### US or Metric Units

The VT2218 can be programmed to display in either US or Metric units. The default is US units. To change units to Metric, use the programming steps above to scroll to **SETUP MODE**. Press **SET** and the default US units will begin to flash. Press the **DOWN** button to change to Metric. The **UP** button will change back to US units. When the desired units are flashing, press the **SET** button.

### 7. Reading the LCD screen:

The LCD screen will display important diagnostic information:

**Operating Mode** - Delta-T, Constant Speed, Set Point Heat, Set Point Cool, or Boiler Protection.

**Setting** - Delta-T target, Fixed speed, Set Point target temperature, or Boiler Protection target minimum temperature.

**Watts** - Power usage of the circulator.

**GPM** - Flowrate through system.

**S** - **Supply** sensor temperature.

**R (or BP)** - **Return** sensor temperature (or **Boiler Return** temperature in Set Point mode).

### 8. Sequence of Operation - How the VT2218 Works:

#### Delta-T Mode (5°F - 50°F, default = 20°F)

In Delta-T mode, the VT2218 will start at the lowest speed. If it reads a temperature differential ( $\Delta T$ ) LESS than its target, it will gradually increase speed through a 3 minute "Start Cycle" to its highest speed, until target  $\Delta T$  is reached. "Start Cycle" will display on the LCD screen in place of "Watts". If  $\Delta T$  is GREATER than target, the pump will immediately go into Variable Speed operation and vary speed to maintain the target  $\Delta T$ .

#### Constant Speed Mode (Speeds 1, 2, 3, 4, default = Speed 4)

In Constant Speed mode, the VT2218 will always start and run at the pre-set Speed Level (1 through 4). Only watts will be displayed. Temperature sensors are not active in this mode.

#### Set Point Heat Mode (with Boiler Protection (BP) option) (50°F - 220°F, default = 105°F, BP default = 140°F)

In Set Point Heat mode, the VT2218 will start at the lowest speed. It then immediately switches to Variable Speed operation, increasing speed to raise temperature or decreasing speed to lower temperature and maintain the Set Point Heat target.

If Boiler Protection (BP) option is used with Set Point Heat, the return sensor (R) will over-ride the supply sensor (S) and slow the pump down if boiler return water temperature falls below BP target (for example 140°F). Once the return sensor reads BP target, the pump will then speed up to reach the supply temperature Set Point target. In this mode the return sensor will read "BP" on the LCD.

#### Set Point Cool Mode (32°F - 100°F, default = 70°F)

In Set Point Cool mode, the VT2218 operates in the reverse of Set Point Heat. It will start at the lowest speed. It then immediately switches to Variable Speed operation, increasing speed to lower temperature or decreasing speed to raise temperature and maintain the Set Point Cool target.

#### Boiler Protection (BP) Mode (100°F - 160°F, default = 140°F)

**Note:** Boiler Protection Mode is designed to maintain a minimum boiler temperature to prevent flue gas condensation.

**CAUTION: Do not attempt to remove LCD panel from circulator. Serious damage to circulator electronics may result.**

**ATTENTION: N'essayez pas de retirer le panneau de LCD du circulateur. Des dommages sérieux à l'électronique du circulateur peuvent en résulter.**



## 9. Troubleshooting the error codes:

**SureStart Feature:** The VT2218 is programmed with an automatic unblocking feature. In the case of a locked rotor condition, it will attempt to unblock the rotor with a series of rapid oscillating actions. It will repeat this process up to 100 times. If still locked after 100 attempts, "LOCKED ROTOR" will appear on the LCD. See error code listing below.

Listed below are potential diagnostic error codes which will appear on the LCD display in case of a malfunction.

ERROR CODE*	DESCRIPTION	CORRECTIVE ACTION
SENSOR 1 MISSING	Supply sensor disconnected.	Reconnect sensor.
SENSOR 2 MISSING	Return sensor disconnected.	Reconnect sensor.
SENSOR 1 SHORTED	Bad sensor.	Replace sensor.
SENSOR 2 SHORTED	Bad sensor.	Replace sensor.
AC INPUT UNDER VOLTAGE	Low voltage problem.	Check power supply.
AC INPUT OVER VOLTAGE	High voltage problem.	Check power supply.
LOCKED ROTOR	Probable locked rotor or motor failure.	Replace pump.
MOTOR OVER CURRENT	Possible locked rotor or motor over current.	Replace pump.
OVER TEMPERATURE	PC Board overheating.	Pump will reduce current and speed until PCB temperature is acceptable. If speed falls below 1650 RPM, pump will stop on safety. Cycle AC power OFF/ON to restart.

\* Flashing Displayed on LCD

### Testing the Sensors

A good quality test meter capable of measuring up to 5,000 k $\Omega$  (1 k $\Omega$  = 1000 $\Omega$ ) is required to measure the sensor resistance. In addition to this, the actual temperature must be measured with a good quality digital thermometer.

First measure the temperature using the thermometer and then measure the resistance of the sensor at the VT2218. The wires from the sensor must not be connected to the circulator while this test is performed. The wiring terminals are easily removed by pulling them from the circulator. Using the chart below, estimate the temperature measured by the sensor. The sensor and thermometer readings should be close. If the test meter reads a very high resistance, there may be a broken wire, a poor wiring connection or a defective sensor. If the resistance is very low, the wiring may be shorted, there may be moisture in the sensor or the sensor may be defective. To test for a defective sensor, measure the resistance directly at the sensor location.

Temperature		Resistance	Temperature		Resistance	Temperature		Resistance	Temperature		Resistance
°F	°C	$\Omega$	°F	°C	$\Omega$	°F	°C	$\Omega$	°F	°C	$\Omega$
-30	-34	234,196	30	-1	34,558	90	32	7,334	150	66	2,045
-20	-29	165,180	40	4	26,099	100	38	5,828	160	71	1,689
-10	-23	118,018	50	10	19,900	110	43	4,665	170	77	1,403
0	-18	85,362	60	16	15,311	120	49	3,760	180	82	1,172
10	-12	62,465	70	21	11,883	130	54	3,050	190	88	983
20	-7	46,218	80	27	9,299	140	60	2,490	200	93	829

### Pump Cross Reference (Constant Speed Mode):

SPEED	TACO	GRUNDFOS	WILO	B & G/XYLEM	ARMSTRONG
1	003	Alpha-15-55 (1)	-	-	-
2	006	Alpha-15-55 (2)	-	-	Compass (1)
3	007 008 0015-1 0015-2	UP-15-42 UPS-15-58 (1) UPS-15-58 (2)	Star S-2 (1) Star S-21 (2)	NRF-25 (1) NRF-25 (2)	Astro 230 (1) Astro 230 (2) Compass (2)
4	0015-3	UPS-15-58 (3) Alpha-15-55 (3)	Star S-21 (3)	NRF-25 (3) Eco-Vario	Astro 230 (3) Compass (3)

### Pump Cross Reference (Delta-T Mode):

MODE	TACO	GRUNDFOS	WILO	B & G/XYLEM	ARMSTRONG
Delta-T	008-VDT	Alpha 15-55	Stratos Eco 16FX	Eco-Auto 19-14	Compass 2020

## VT2218 PERFORMANCE CURVES

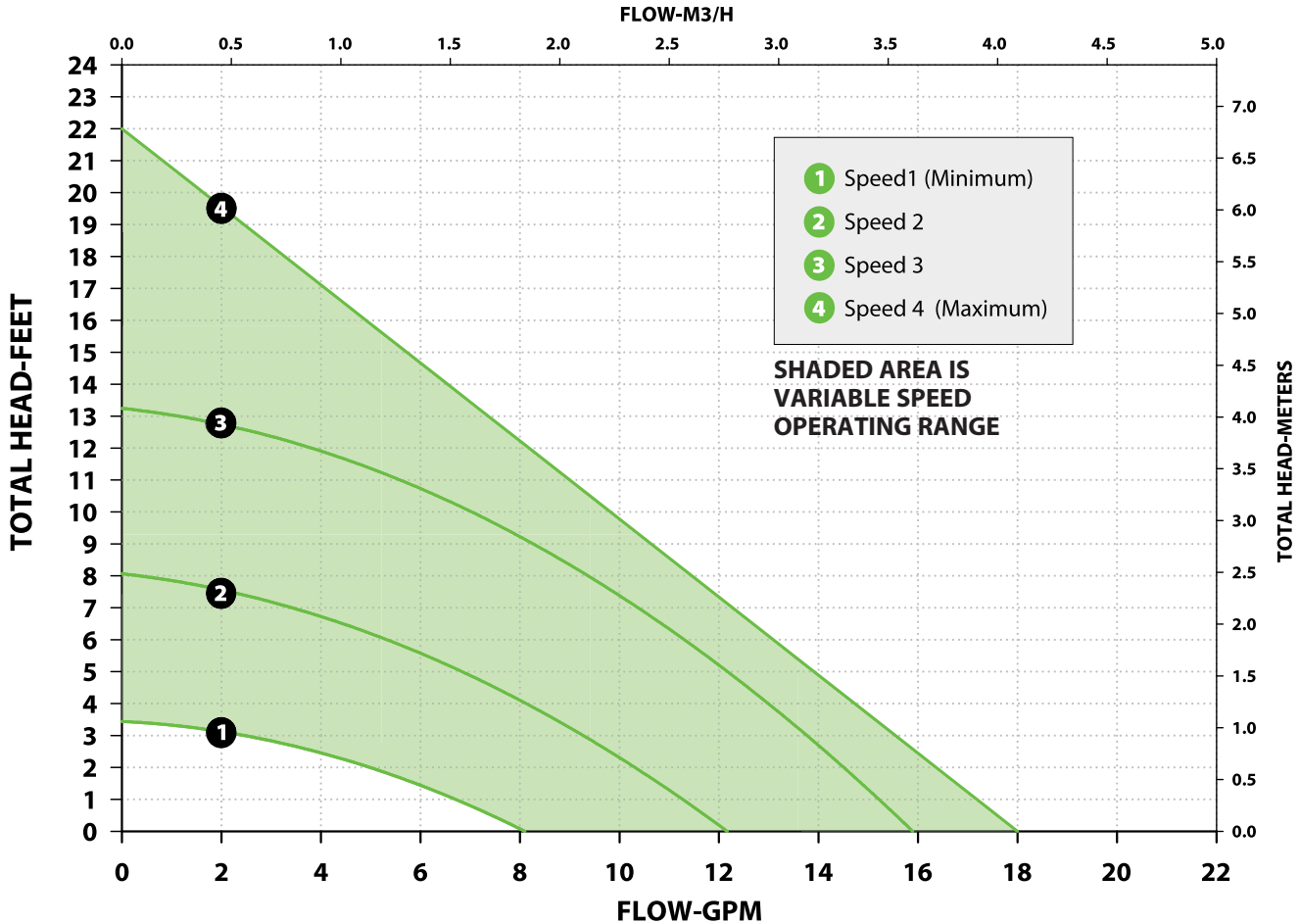

## LIMITED WARRANTY STATEMENT

Taco, Inc. will repair or replace without charge (at the company's option) any Taco High Efficiency circulator or circulator part which is proven defective under normal use within three (3) years from the date of manufacture.

In order to obtain service under this warranty, it is the responsibility of the purchaser to promptly notify the local Taco stocking distributor or Taco in writing and promptly deliver the subject product or part, delivery prepaid, to the stocking distributor. For assistance on warranty returns, the purchaser may either contact the local Taco stocking distributor or Taco. If the subject product or part contains no defect as covered in this warranty, the purchaser will be billed for parts and labor charges in effect at time of factory examination and repair.

Any Taco product or part not installed or operated in conformity with Taco instructions or which has been subject to misuse, misapplication, the addition of petroleum-based fluids or certain chemical additives to the systems, or other abuse, will not be covered by this warranty.

If in doubt as to whether a particular substance is suitable for use with a Taco product or part, or for any application restrictions, consult the applicable Taco instruction sheets or contact Taco at (401-942-8000).

Taco reserves the right to provide replacement products and parts which are substantially similar in design and functionally equivalent to the defective product or part. Taco reserves the right to make changes in details of design, construction, or arrangement of materials of its products without notification.

**TACO OFFERS THIS WARRANTY IN LIEU OF ALL OTHER EXPRESS WARRANTIES. ANY WARRANTY IMPLIED BY LAW INCLUDING WARRANTIES OF MERCHANTABILITY OR FITNESS IS IN EFFECT ONLY FOR THE DURATION OF THE EXPRESS WARRANTY SET FORTH IN THE FIRST PARAGRAPH ABOVE.**

**THE ABOVE WARRANTIES ARE IN LIEU OF**

**ALL OTHER WARRANTIES, EXPRESS OR STATUTORY, OR ANY OTHER WARRANTY OBLIGATION ON THE PART OF TACO.**

**TACO WILL NOT BE LIABLE FOR ANY SPECIAL, INCIDENTAL, INDIRECT OR CONSEQUENTIAL DAMAGES RESULTING FROM THE USE OF ITS PRODUCTS OR ANY INCIDENTAL COSTS OF REMOVING OR REPLACING DEFECTIVE PRODUCTS.**

This warranty gives the purchaser specific rights, and the purchaser may have other rights which vary from state to state. Some states do not allow limitations on how long an implied warranty lasts or on the exclusion of incidental or consequential damages, so these limitations or exclusions may not apply to you.

**Taco, Inc.**, 1160 Cranston Street, Cranston, RI 02920 | Tel: (401) 942-8000 | FAX: (401) 942-2360  
**Taco (Canada), Ltd.**, 8450 Lawson Road, Suite #3, Milton, Ontario L9T 0J8 | Tel: (905) 564-9422 | FAX: (905) 564-9436  
 Visit our web site: [www.TacoComfort.com](http://www.TacoComfort.com) | Printed in USA | ©2015 Taco, Inc.