

HYMAX 2

HYMAX[®] 2 COUPLING (1.5" - 12")



FEATURES

- ADVANCED WIDE-RANGE COUPLING WITH A PATENTED FLIP GASKET
- ELIMINATES GASKET REMOVAL MISTAKES AND MAXIMIZES INSTALLER WORK EFFICIENCY
- ONLY 2-4 TOP FACING BOLTS, FOR FASTER AND SAFER INSTALLATION
- READY-TO-USE DESIGN TO ELIMINATE EXTENSIVE UNDER-PIPE DIGGING
- ALLOWS 4° DYNAMIC DEFLECTION ON EACH END, REDUCING FUTURE PIPE DAMAGE
- PATENTED HYDRAULICALLY-ASSISTED GASKET WITH 2-STAGE SEALING
- SUITABLE FOR ALL TYPES OF PIPES - DUCTILE IRON, CAST IRON, STEEL, COPPER, PE, PVC, AC, GRP
- ONE PRODUCT CAN CONNECT PIPES OF TWO DIFFERENT MATERIALS
- BASED ON THE GAME-CHANGING HYMAX THAT HAS BEEN FIELD-PROVEN IN MILLIONS OF INSTALLATIONS IN THE US
- PRODUCT PERFORMANCE, OD RANGE AND PRESSURES ARE IDENTICAL TO THOSE OF THE ORIGINAL HYMAX
- LIFTING T-HANDLE EXISTS IN SIZES 3"-12" ONLY

SPECIFICATIONS

STANDARDS	SIZE	MATERIALS
HYMAX2 MEETS OR EXCEEDS STANDARDS AWWA C-219, NSF 61, NSF 372.	AVAILABLE IN NOMINAL DIAMETER FROM 1.5" - 12" STANDARD. CALL KRAUSZ FOR DETAILS.	<p>END RINGS ASTM A283 / A283M GRADE C STEEL.</p> <p>CENTER RING ASTM A53 GRADE A STEEL.</p> <p>GASKETS EPDM COMPOUNDED FOR WATER AND SEWAGE, MEETS INTERNATIONAL STANDARDS FOR CONTACT WITH DRINKING WATER.</p> <p>BRIDGE AVAILABLE IN AISI 304 OR SS316* STAINLESS STEEL</p> <p>SPHERICAL SPACERS AVAILABLE IN AISI 304 OR SS316* STAINLESS STEEL</p> <p>COATING 100% FUSION BONDED EPOXY FOR ENHANCED CORROSION PROTECTION. AVERAGE THICKNESS 14 MIL.</p> <p>NUTS & BOLTS AVAILABLE IN AISI 304 OR SS316* STAINLESS STEEL. ROLLED THREAD AND ANTI-GALLING COATING.</p>

* SS316 - Coming Soon

PRODUCT SPECIFICATIONS

HYMAX 2



PRODUCT PERFORMANCE

WORKING TEMPERATURE	-20°F UP TO +125°F		
DYNAMIC DEFLECTION	UP TO 4° PER SIDE		
MIN. PIPE INSERTION	2.25"		
MAXIMUM OFFSET FOR MISALIGNED PIPES	ND 1.5" - ND 3"	ND 4" - ND 12"	
	0.39"	0.51"	
MAXIMUM OUT OF ROUNDNESS	ND 1.5"	ND 2" - ND 3"	4" - 12"
	0.08"	0.20"	0.31"
WORKING PRESSURE	260		
RATED PRESSURE	390		
VACUUM TEST	12 PSI		

PRODUCT TABLES

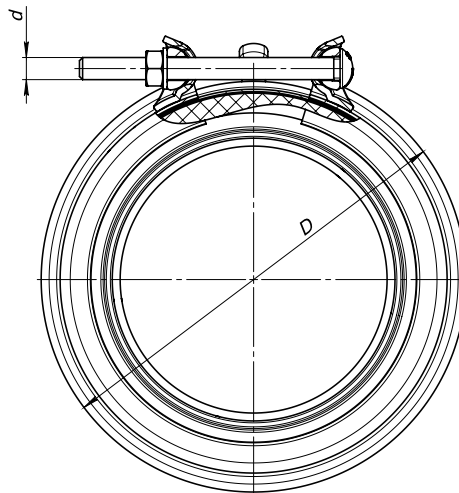
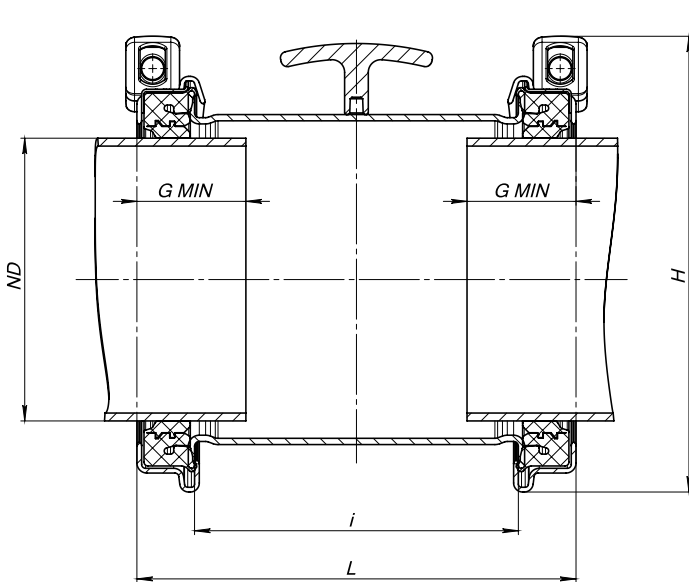

PRODUCT SPECIFICATIONS

HYMAX 2



PRODUCT TABLES

HYMAX® 2 NOMINAL SIZES (1.5" - 12")

When XX = 54 - Fasteners are AISI 304

When XX = 94 - Fasteners are SS316*

Krausz Part Number	Nominal Diameter (inch)	Overall Range (inch)	Range in closed gasket position (inch)	Range in open gasket position (inch)	Bolt Qty. and Size (mm)	Torque (Ft-Lbs)	Approx. Weight (Lbs)	Length (inch)
860-XX-0041-16	1.5	1.61-2.13	1.61-1.97	1.96-2.13	2 -M12	35	5	6.1
860-XX-0054-16	2	2.10-3.03	2.10-2.60	2.56-3.03	2 -M12	50	7.5	6.8
860-XX-0088-16	3	3.46-4.33	3.46-3.90	3.86-4.33	2 -M12	50	10.8	8.8
860-XX-0108-16	4	4.25-5.63	4.25-5.00	4.92-5.63	2 -M14	75	15	8.8
860-XX-0130-16	5	5.12-6.38	5.12-5.75	5.71-6.38	2 -M14	75	19	10.8
860-XX-0163-16	6	6.42-7.68	6.42-7.05	7.01-7.68	2 -M14	75	23	10.8
860-XX-0190-16	7	7.48-8.74	7.48-8.11	8.07-8.74	2 -M14	75	24	10.8
860-XX-0217-16	8	8.54-9.84	8.54-9.17	9.13-9.84	2 -M14	75	28	10.8
860-XX-0272-16	10	10.70-12.00	10.70-11.37	11.33-12.00	2 -M14	75	32	10.8
860-XX-0278-16	10	10.96-12.26	10.96-11.63	11.59-12.26	2 -M14	75	33	10.8
860-XX-0315-16	12	12.40-13.66	12.40-13.03	12.99-13.66	2 -M14	80	39	10.8
860-XX-0334-16	12	13.15-14.41	13.15-13.78	13.74-14.41	2 -M14	80	39	10.8

For specific sizes of products in stock, call Krausz for details. Copyright © 2017 Krausz Industries Ltd., All rights reserved

* SS316 Coming Soon