



A CSW Industrials Company

TRUaire 210 Series

Single deflection 3/4" Blade Spacing
Sidewall or Ceiling Grille/Register

Model: _____ Size: _____

Project Information:

Job Name: _____

Location: _____

Engineer: _____

Submitted to: _____

For: Reference Approval Construction

Submitted by: _____

Reference: _____

Submittal Information:

Approval: _____

Date: _____

Construction: _____

Unit #: _____

Drawing #: _____

Construction Options

Aluminum Construction

Steel Construction

Horizontal Blades

Vertical Blades

Finish Options

Pristine White Powder Coat Finish

Aluminum Powder Coat Finish

Following plating options are available only on steel models.

Brushed Nickel Plating

Oil Rubbed Bronze Plating

Polished Nickel Plating

(Sec. I) Features

- One Piece Construction (Up to 14" x 10")
- Individually Adjustable Blades
- Unique Beveled Edges on Steel Models
- Airfoil Blades on Aluminum Models
- #8 x 2" Long Mounting Hardware

(Fig. I) Product Image:

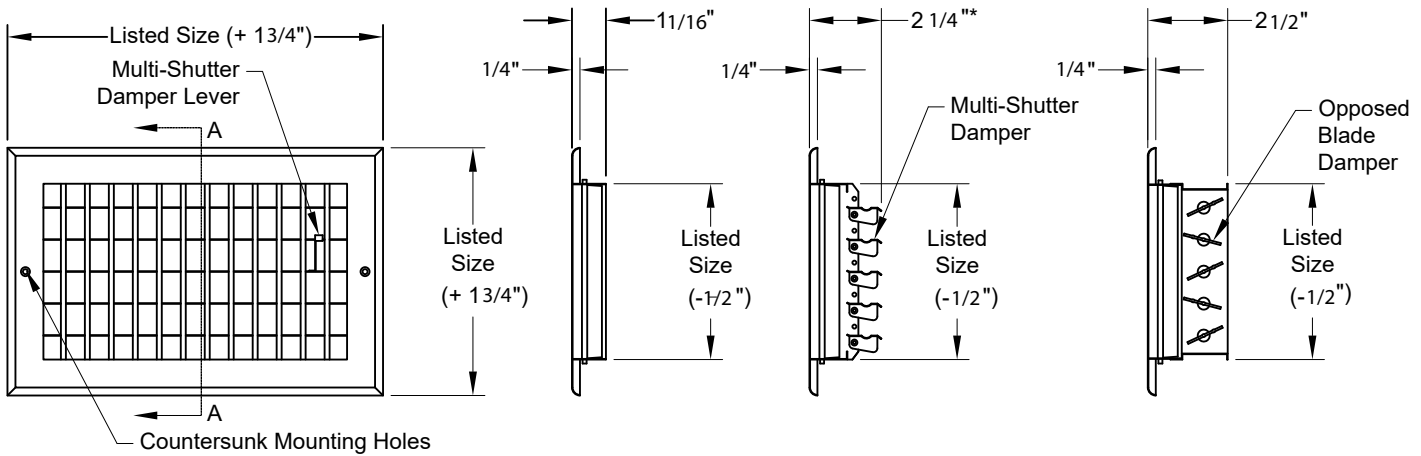

210VM shown; all dimensions are typical for the 210 series

Section AA

Grille Only

Section AA

SmoothGlide™ Multi-Shutter Damper

Section AA

Opposed Blade Damper

Note: This submittal is meant to demonstrate the general dimensions of this product. The illustrations are not meant to detail every aspect of the product. Drawings are not to scale.



RectorSeal® • 2601 Spenwick Drive • Houston, TX 77055 • 800-231-3345 • rectorseal.com

A CSW Industrials Company. RectorSeal, the logos and other trademarks are property of RectorSeal, LLC, its affiliates or its licensors and are protected by copyright, trademark and other intellectual property laws, and may not be used without permission. RectorSeal reserves the right to change specifications without prior notice. ©2023 RectorSeal. All rights reserved. R50956-0323