

NOTES:

(N1) 1. FIT / FORM / FUNCTION SHALL FOLLOW PS-E.008.

BILL OF MATERIAL (CURRENT LEVEL)

ITEM	PT/ASSY	DESCRIPTION	TYPE	QTY.
1	1-676	W/S VALVE INSTALLATION	ASSEMBLY	1
2	3-579	W/S SPOUT ASM	ASSEMBLY	1
3	3-580	LEVER HANDLE W/ESC.	ASSEMBLY	2
4	12551	POP UP KNOB	PART	1
5	10288	3/16" POP UP ROD	PART	1
6	325	POP UP ASSEMBLY	ASSEMBLY	1
7	91571	AERATOR KEY	PART	1

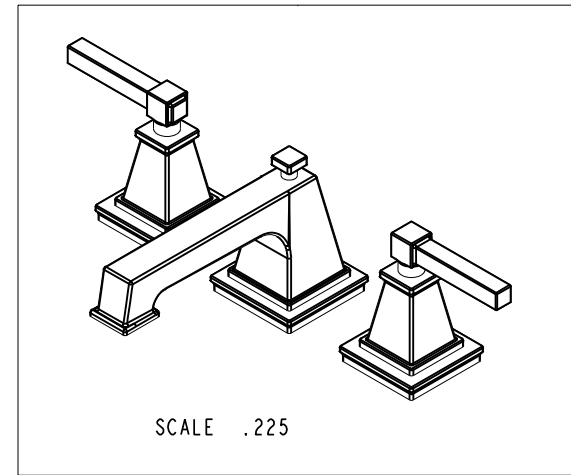
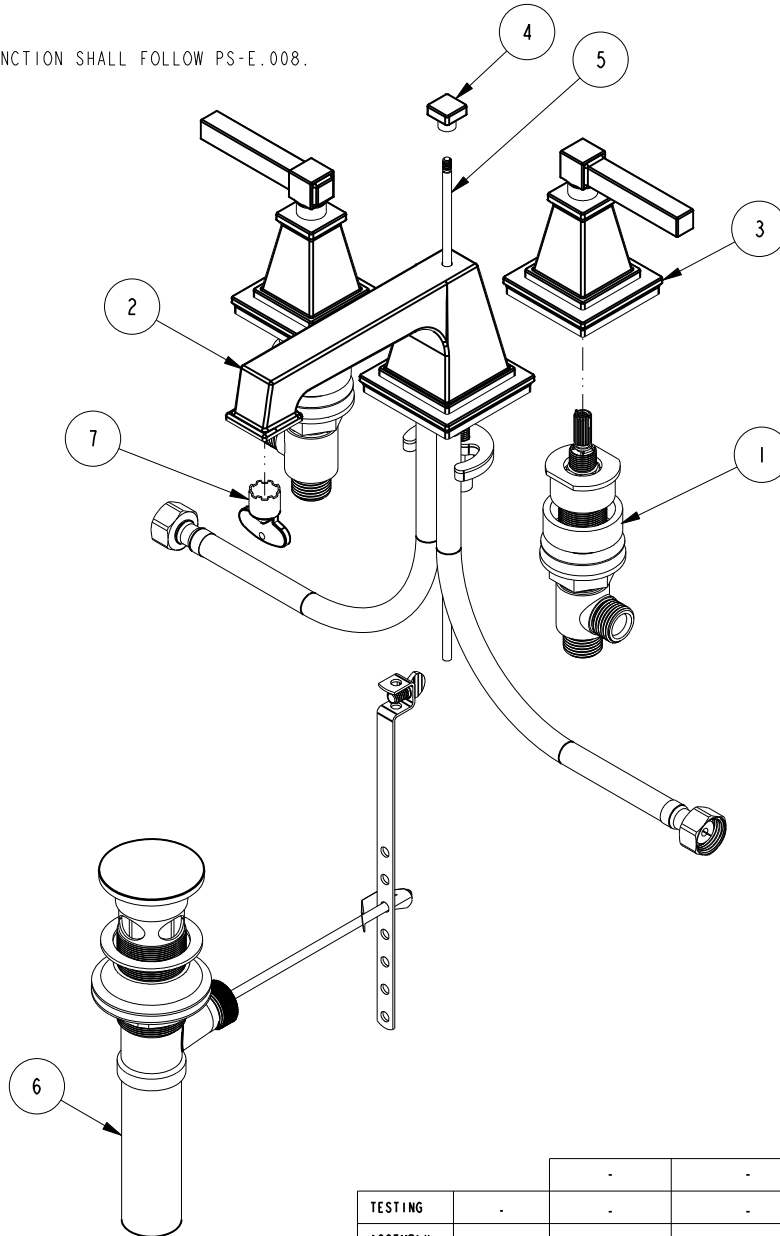

ZONE	REV	DESCRIPTION	DATE	APPROVED
-	B	EN-3601	05/07/18	V.V.
-	A	EN-3189	11/10/16	J.M
-	-	EN-3061	08/10/16	J.M

COPYRIGHT 2005 BRASSTECH, INC. THESE DRAWINGS AND THE DESIGNS DEPICTED HEREIN ARE THE PROPRIETARY PROPERTY OF BRASSTECH. ANY USE OR REPRODUCTION IS SUBJECT TO THE EXPRESS APPROVAL OF BRASSTECH. UNAUTHORIZED USE IS STRICTLY PROHIBITED. ALL RIGHTS RESERVED.

TESTING	-	-	-
ASSEMBLY	-	-	-
PLATING	-	-	-
POLISHING	-	NEXT ASSY	USED ON
MACHINING	-	APPLICATION	
TOOLING FIXTURE #		REMOVE ALL BURRS AND SHARP EDGES	

UNITS ARE: INCHES [MM]	
TOLERANCES ARE:	
FRACTIONS DECIMALS	ANGLES
±1/16"	.X ±.1 [2.5] ±1°
	.XX ±.06 [1.5]
(X.XXX) DENOTES CRITICAL DIMS. ALL THREADS ARE CRITICAL	
DRAWN	JINSON 08/10/16
CHECKED	RAVINDRA 08/10/16
APPROVED	J.M 08/10/16

BRASSTECH 2001 CARNEGIE AVE. SANTA ANA, CA 92705 (949) 417-5207
INCORPORATED

WIDESPREAD FAUCET

DWG NO. **3140** REV B

SCALE .250 REF. - SHEET 1 OF 2

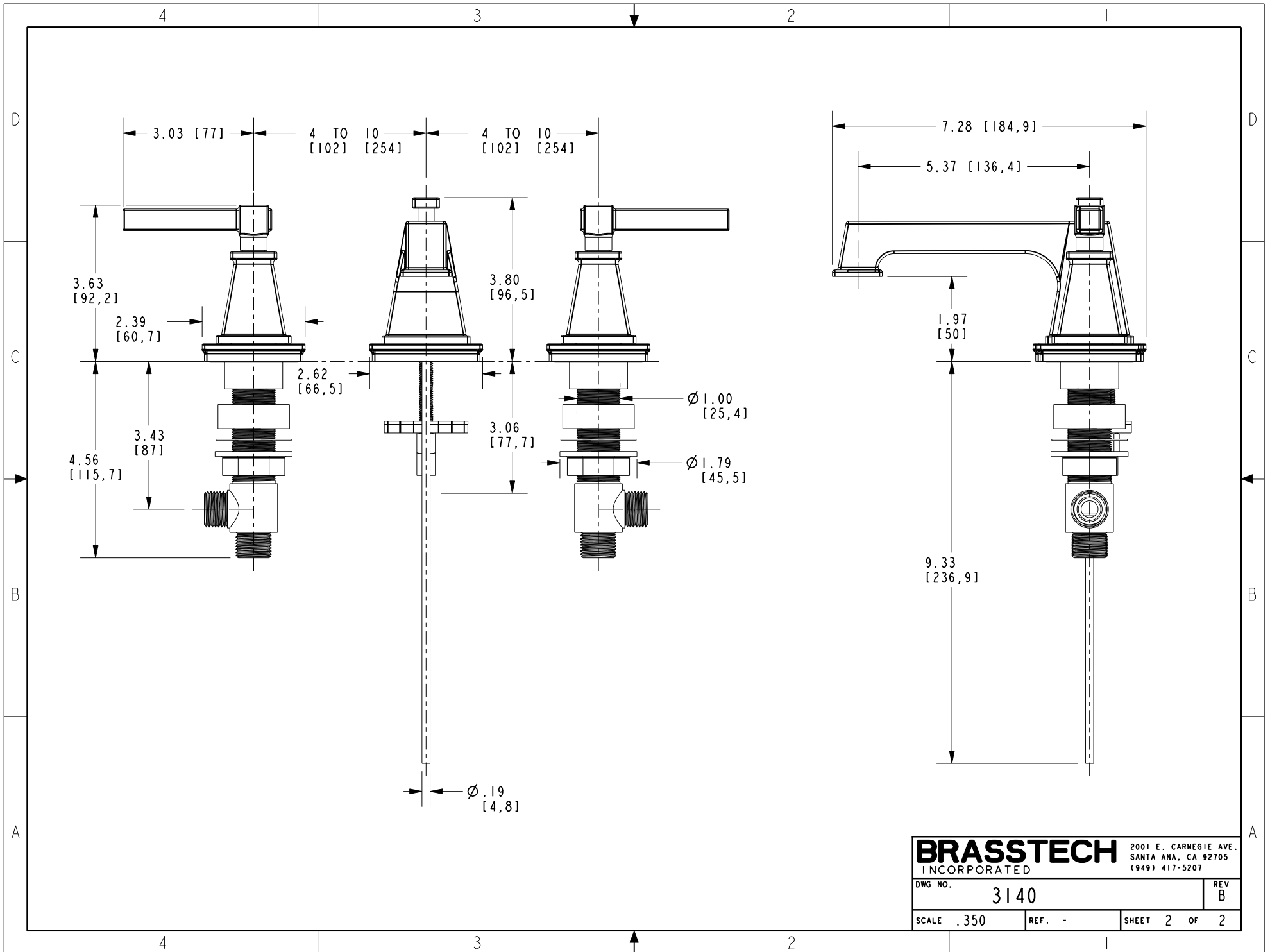

BRASSTECH		2001 E. CARNEGIE AVE.	
INCORPORATED		SANTA ANA, CA 92705	
DWG NO. 3140		REV B	
SCALE .350	REF. -	SHEET 2 OF 2	