

Installation

S19-322

Recessed Emergency Signaling System

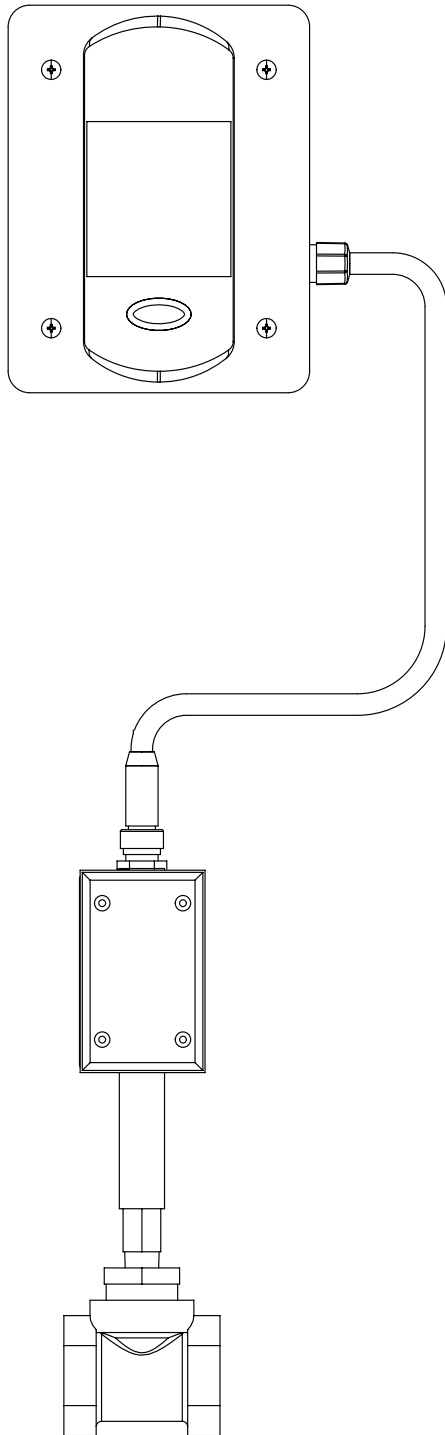

Table of Contents

Pre-Installation Information	2-3
Components	4
Install Flow Switch	5
Mount Signaling Assembly	6
Connect Signaling Assembly	6
Complete Electrical Supply Connections	7
Test the Signaling System	7
Maintenance	8
Remove Sensing Option	8
Service of Lights	8
Troubleshooting	9
Service Parts	10



WARNING

Power supplied to the unit should be between 90-264VAC, 50-60 Hz, 15 amp branch circuit with a dedicated circuit breaker or fuse and should not supply power to any other device. Compliance and conformity to local codes and ordinances is the responsibility of the installer.

Do not use this safety equipment in a location that does not match its hazardous location rating. Verify the appropriate ratings prior to installation.

When making electrical connections be sure to follow all lockout–tagout safety procedures.

Flush the water supply lines before beginning installation and after installation is complete. Test the unit for leaks and adequate water flow. Main water supply should be “ON” at all times unless system is being serviced. Provisions shall be made to prevent unauthorized shutoff.

CAUTION

Supply the unit with clean, potable water.

NOTICE

Before installing this product, ensure that there are adequate clearances around the product and activation of the product does not interfere with other products or obstructions.

It is recommended that all water supply and electrical connections be made at temperatures above freezing. Failure to do so may result in major product and/or property damage.

Constant power supply to safety equipment is necessary for it to function.

Avoid cleaners containing organic solvents, alcohols and hydrocarbons. Rinse with potable water after cleaning.

IMPORTANT

The installation and location of all safety drench showers, eye and eye/face washes must comply with the requirements of ANSI/ISEA Z358.1.

Read this installation manual completely to ensure proper installation, then file it with the owner or maintenance department. Compliance and conformity to local codes and ordinances is the responsibility of the installer.

Separate parts from packaging and make sure all parts are accounted for before discarding any packaging material. If any parts are missing, do not begin installation until you obtain the missing parts.

Installation and maintenance of this system must be completed by a qualified plumber and electrician according to the information contained in this installation manual and in compliance with all national and local codes.

The ANSI/ISEA Z358.1 standard requires an uninterrupted supply of flushing fluid. Bradley plumbed emergency fixtures require a minimum of 30 PSI (0.21MPa) flowing pressure.

Weekly activation must be conducted on all plumbed emergency equipment to ensure a suitable flushing fluid supply is present and any sediment build up in the supply line is cleared. Inspect safety equipment monthly to address any maintenance issues ensuring the equipment is in good operating condition and that there are no signs of wear.

Perform functional test upon relocation of safety equipment.

Workers who may come in contact with potentially hazardous materials should be trained regarding the placement and proper operation of emergency equipment per ANSI/ISEA Z358.1.

For questions regarding the operation or installation of this product, visit www.bradleycorp.com or call 800-BRADLEY (272.3539).

Product warranties and parts information may also be found under "Products" on our web site at bradleycorp.com.

Supplies Required

- Appropriate hardware to mount control box to in-wall studs
- Black, white and green AWG 18 minimum (14 AWG maximum) wire to connect signaling system to electric power supply, use copper wire only
- 3/4" conduit fittings for electrical wiring (all customer supplied hubs and fittings must match the electrical rating of the enclosures)

S19-322 Components

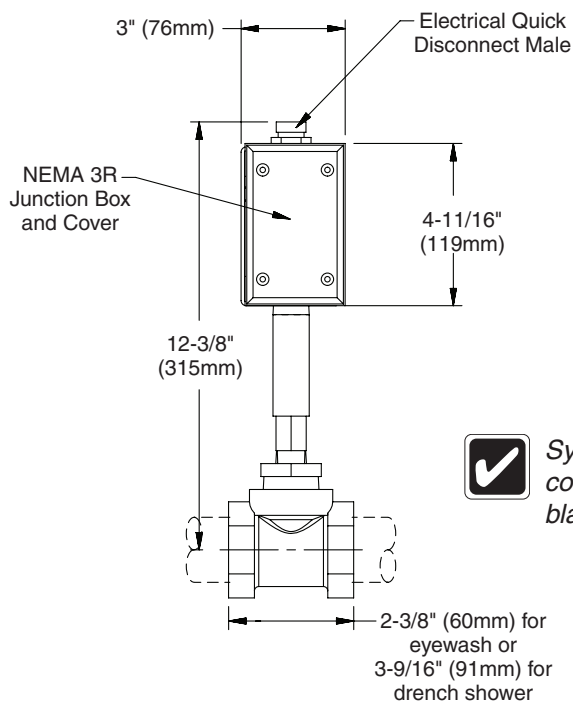
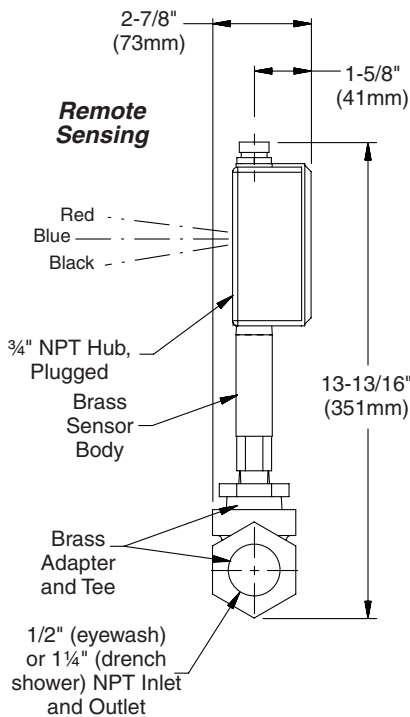
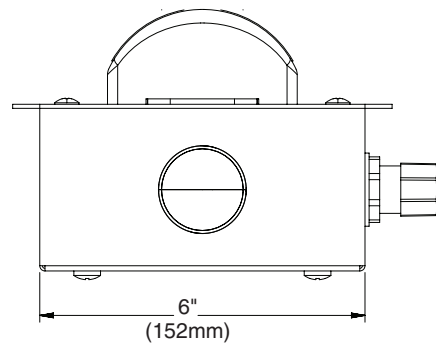
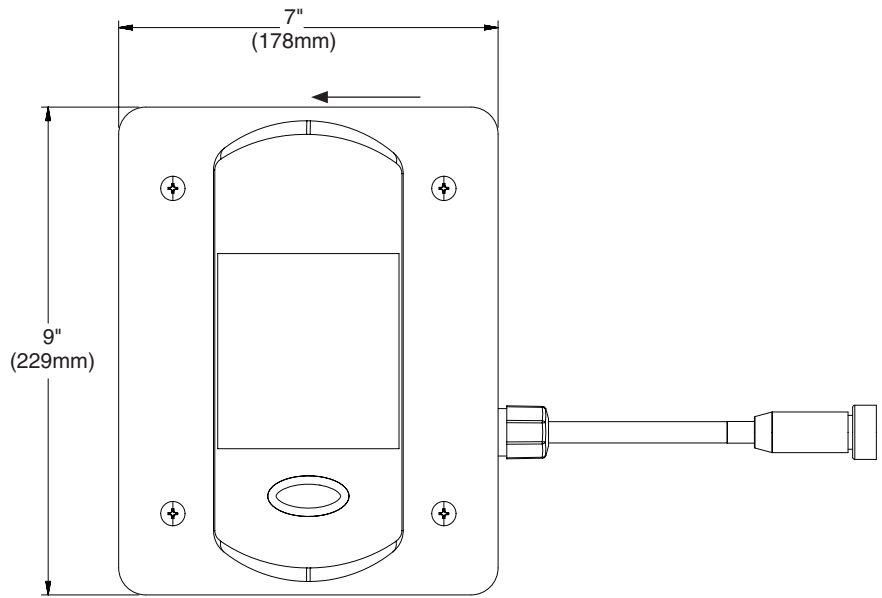
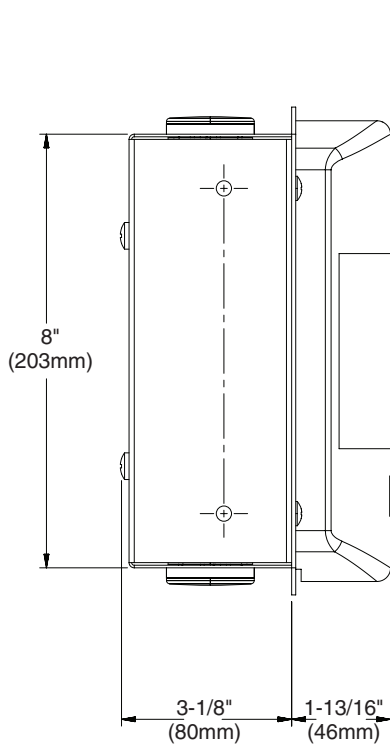

 System is prewired. Installer connects **ONLY** ground black and white wires.

1 Install the Flow Switch



The flow switch will attach to the mounted alarm via a 6 foot waterproof cable. Keep the location for mounting the alarm in mind when choosing the flow switch location.

A Choose a location for mounting the flow switch in a horizontal run of the water supply line.

Mount the flow switch assembly in the water supply line.

- The switch body must be in the vertical position with the water pipe horizontal.

B

- The water flow must be in the direction marked by the arrow on the flow switch body.
- Use teflon tape or pipe sealant (supplied by installer) on all water pipe connections.

For drench shower or combination units

1 1/4" to 1" Reducing Bushing may be required based on model. Flow switch is 1-1/4" on inlet and outlet.

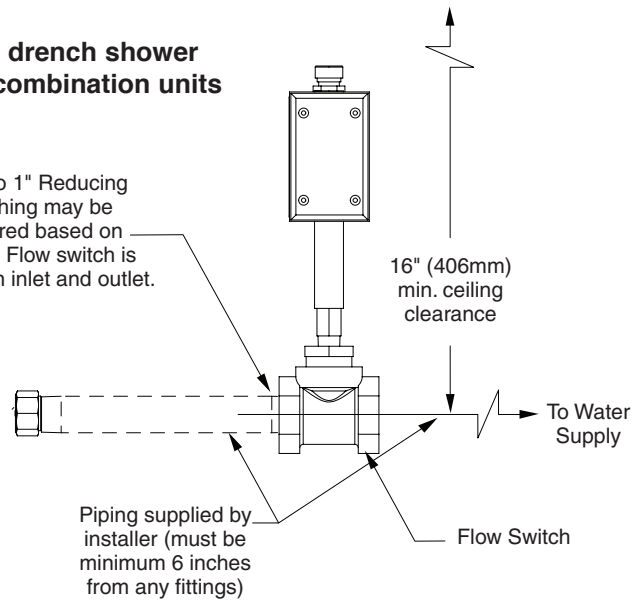

For eye or eye/face wash units

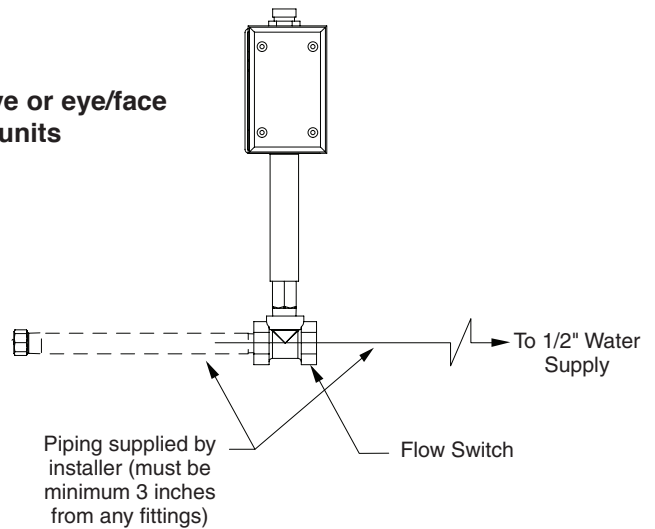

2 Mount the Signaling Assembly in Wall

 Recessed signaling system display needs to be installed in a location where it is not in the direct spray pattern of a drench shower.

A Remove the four screws on the front panel/cover to install the control box.

B Unplug the connector that attaches the wire to the front panel, located in the lower right hand corner of the control board. Set the front panel aside.

C Choose a location for mounting the signaling assembly. The signaling assembly should be mounted at least 7 feet above ground level for best visibility.

D Size appropriate hole to mount the signaling system in. The wall must have sufficient depth to accommodate the flush mounting of the control box.

E Mount the control box to the in wall studs using the holes provided and fasteners (customer provided).

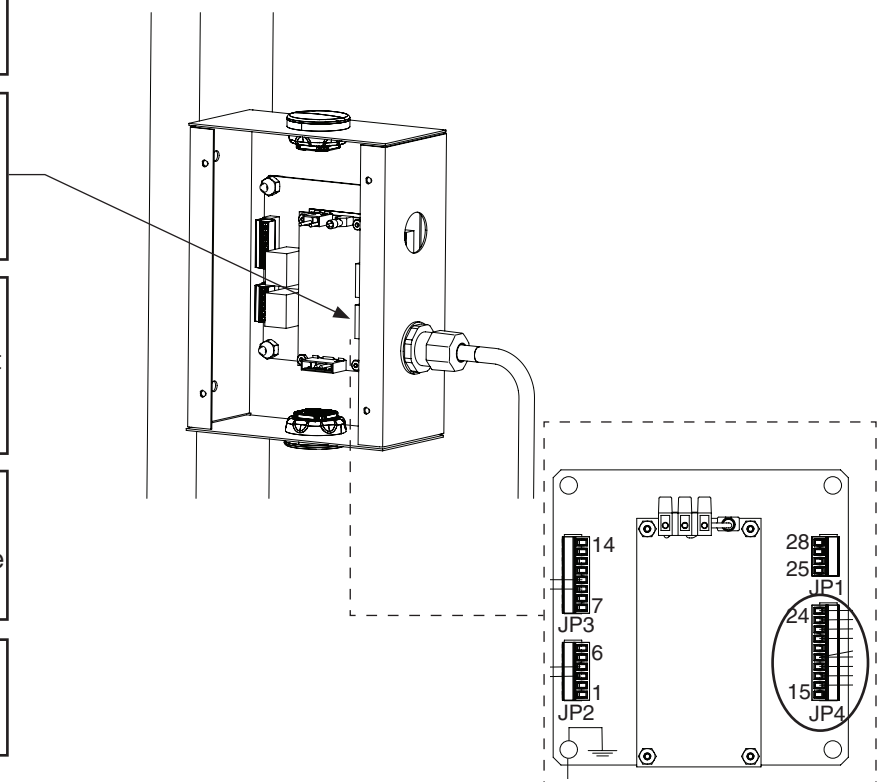

3 Connect Signaling Assembly to Flow Switch

A Connect the flow switch to the signaling system by plugging the prewired cable into the socket provided in the flow switch junction box. The plug and socket have an alignment pin and groove which makes for error-free hook-up.

 Make sure cable is not taut to prevent undue stress to cable and connector.

B Tighten the locking collar on the female cable socket by rotating it clockwise after plugging in. This makes a good watertight connection.

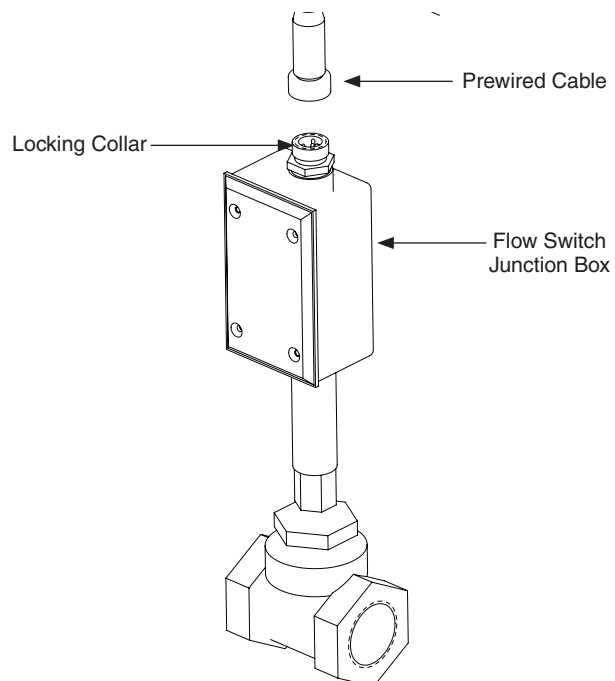

4 Complete electrical supply connections

⚠ WARNING To prevent personal injury and damage to the components, follow all manufacturer's warnings and instructions when performing any maintenance or installation of components used in this emergency signaling system.

A Run electric power conduit (3/4" conduit hub, customer provided) and AWG 18 minimum power wire into the hole to the floating terminal block per the wiring schematic.



See wiring diagram and schematic included in documentation packet.



Do not exceed 14 AWG wire.

B

Re-attach connector from control box to front panel (located on the lower right hand corner of the control board).

C

Re-attach the cover and tighten the four screws.

D

Turn on supply power to the signaling system. Test the signaling system at this time.



Compliance and conformity to local codes and ordinances is the responsibility of the installer.

5 Test the Signaling System



Testing the signaling system for the first time using the drench shower may expose the flow switch to an unnecessary water hammer since the downstream piping may be empty of water. The flow switch is designed to withstand such a water hammer, but using the smaller eyewash flow is recommended.

A

Apply power to the alarm branch circuit. The alarm should remain in the OFF position and the green beacon light will turn on at a steady state.

B

Open the eyewash valve. The horn should sound and the beacon light will become a signal light and flash amber shortly after water flows from the system.



The horn will continue to sound and beacon/signal light will continue to flash as long as the fixture is activated.

C

Close the eyewash valve. Once flow is discontinued, the horn will shut off and the beacon/signal light return to green steady state.



Discontinuing the flow will automatically reset the silence feature.

E

Repeat steps A through D, this time using the drench shower only.



The signaling system is designed to work properly even if both the eyewash and drench shower are used simultaneously. The signaling system will continue to operate so long as either the eyewash or drench shower is still in use.

Signaling System Maintenance

The Bradley Emergency Signaling System is designed to be virtually maintenance free. An occasional damp cloth wiping of the clear dust cover is all that is needed to ensure maximum visual attention-getting ability.

The horn is factory-set at the loudest possible sound level, 85 decibels at 3 feet.

Remote Sensing Option

Flow Switch Capability



See wiring diagram and schematic on pages 11-12.

If remote sensing is wanted, remove the pipe plug from the back of the junction box. Connect the extra black wire (common to both switch arrangements) and the blue wire (normally open switch arrangement) or red wire (normally closed switch arrangement) to your application per local electrical codes. The switch is rated at 5 amps at 125/250VAC and is isolated from the contacts used by the signaling station. The customer supplied connections should be of a type equal to or greater than the junction box's rating to maintain the integrity of the system.

Servicing of Lights

S19-322 LED Light/Horn Replacement

A

De-power the control box by observing standard lock-out tag-out practices.

B

To disconnect the wire leads of the light requiring the bulb to be replaced, use a small blade screwdriver to depress the orange terminal release tab adjacent to the wire's location. With the tab fully depressed, the wire can be easily removed from the terminal location.

C

Remove the 4 nuts which attach the light to the front panel and remove light. This is a sealed light and has no serviceable components, the complete housing must be replaced.

D

Using the old light for reference, prepare the replacement light's lead wire and exposed conductor's lengths.

E

Reverse the disassemble process to reinstall the light.

F

Check that the signaling station is functioning properly once the power is restored by activating the fixture attached to the signaling station.

Troubleshooting

Problem	Cause	Solution
The signal light and horn (if applicable) does not operate when water flows.	No power to the signal station.	Check that the circuit breaker or fuse is supplying power to the signal station
	Component failure.	Check the two 3 Amp 24VDC fuses on the print circuit board in the signal station enclosure.
	No input power.	Check that there is 24VDC being supplied from the power supply mounted on the print circuit board in the signal station enclosure.
	Water flowing in wrong direction for flow switch body.	Verify that the direction of the water flow corresponds to the arrow on the flow switch body.
	Insufficient water flow.	Check that water flow is sufficient (2.4 gallons per minute is required).
	Installation error.	Check all electrical connections, including power supply at the quick-connect cable, from the signal station to the flow switch.
Horn sounds and signal light does not light.	Component failure.	Check light connections and filament in the light.
Beacon light does not operate. (This light should turn off when the signal light turns on and back on when the signal light turns off.)	Fixture in use.	Make sure that the flow switch contacts are open (horn and/or signal light are not ON).
	Power disconnected in error.	Check that the circuit breaker or fuse is supplying power to the signal station.
	Component failure.	Check the 3 Amp 24VDC fuses on the print circuit board in the signal station enclosure.
	No input power.	Check that there is 24VDC being supplied from the power supply mounted on the print circuit board in the signal station enclosure.
	Component failure.	Check light connections and filament in the light.

S19-322 Service Parts

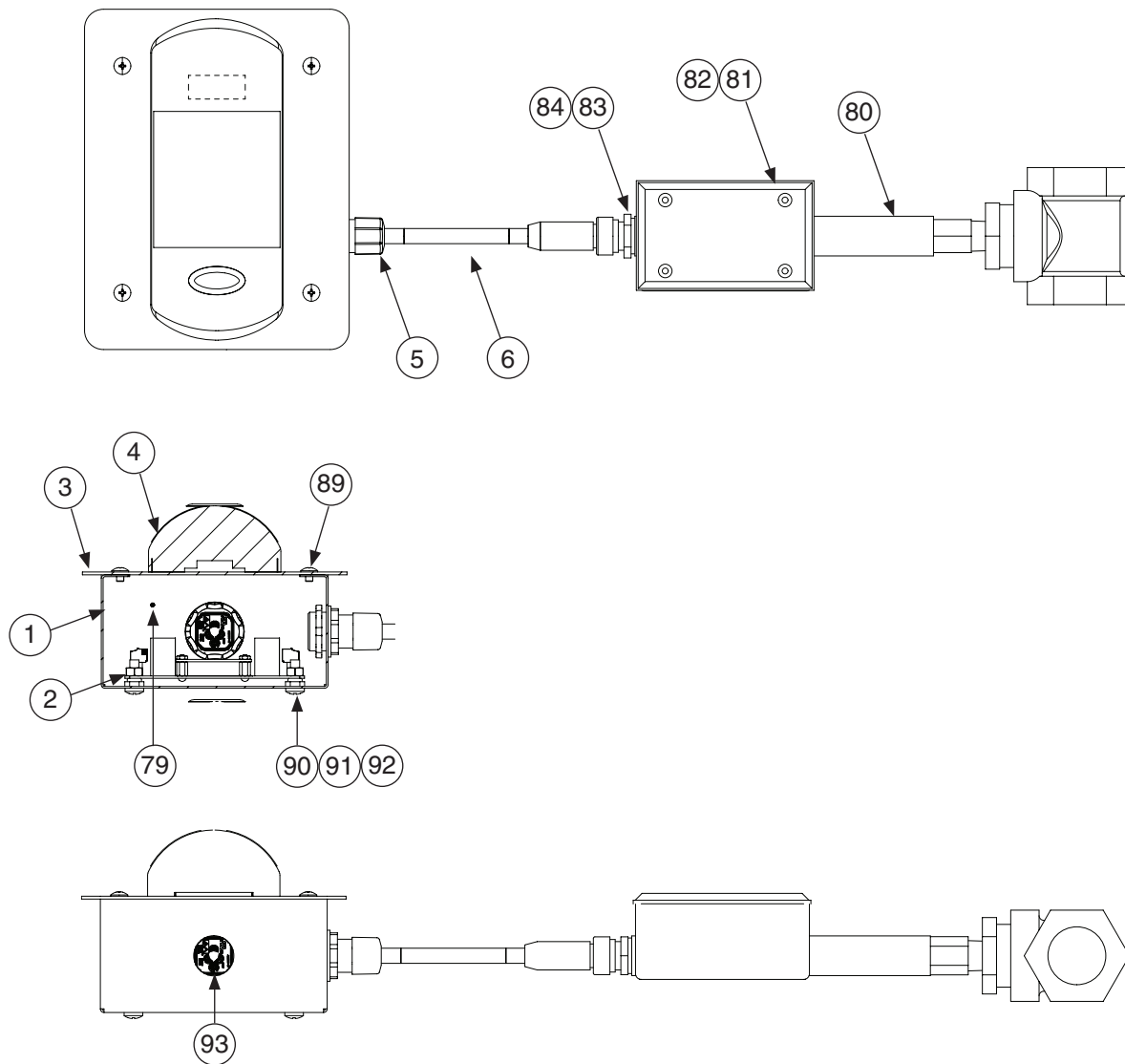

Item	Part No.	Qty.	Description
1	255-072	1	Enclosure, General Area
2	S90-561	1	Signaling System PCB
3	186-1910	1	Panel, Recessed Alarm
4	257-013	1	Light, 2 Color, w/ Buzzer
5	269-2454	1	Cord Grip, 3/4"-4X-200
6	269-524	1	Cond Cable, 6'
79	269-2477	1	Ring, Lug, 1/4 22-16 AWG
80	269-1421	1	Flow Switch - 1-1/4" T-DPDT
80	269-1522	1	Flow Switch - 1/2" T DPDT

Item	Part No.	Qty.	Description
81	269-1902	1	J-Box, 1-Gang
82	269-1903	1	Cover - 1 Gang J-Box
83	269-518	1	Reducing Bushing
84	269-514	1	Cable Receptacle
89	160-490	4	Screw, #10-32x1/4" Phil
90	160-467	4	Screw, 1/4-20x3/4 PN MA
91	161-060	4	Nut, 1/4-20SS Nylon IN
92	161-026	4	Nut, 1/4-20 Hex
93	269-2460	2	Plug, 3/4" Conduit



Light/horn (item 1) includes hardware for attaching it to panel (item 3).