

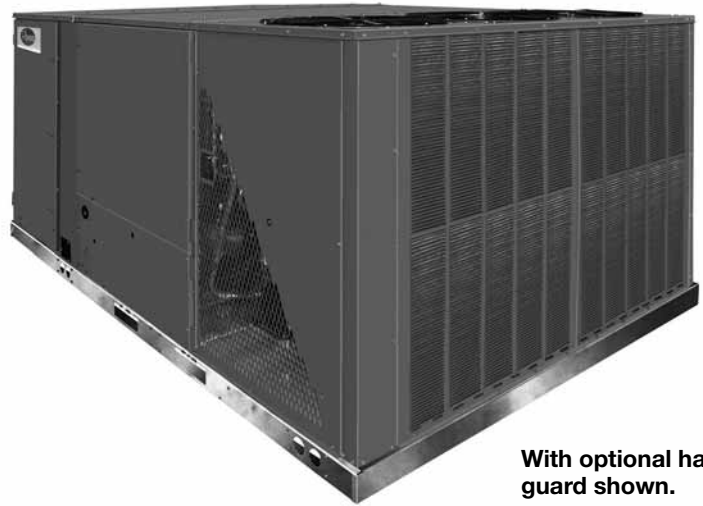

The new degree of comfort.™



Rheem *Commercial Value Series* Package Air Conditioner



With optional hail guard shown.

RLKL-B Standard Efficiency Series

Nominal Sizes 15 & 20 Tons [52.8 & 70.3 kW]
ASHRAE 90.1-2007 Compliant Model



TABLE OF CONTENTS

Unit Features & Benefits	3-7
Selection Procedure	8
Model Number Identification	9
Options	10
General Data	
RLKL-B Series	11-14
General Data Notes	15
Gross Systems Performance Data	
RLKL-B Series	16
Airflow Performance	
RLKL-B Series	17-18
Electrical Data	
RLKL-B Series	19-20
Electric Heater Kits	21-23
Dimensional Data	24-27
Accessories	28-39
Mechanical Specifications	40-44
Typical Wiring	45-46
Limited Warranty	47

These quality features are included in the Rheem Package Air Conditioner Unit

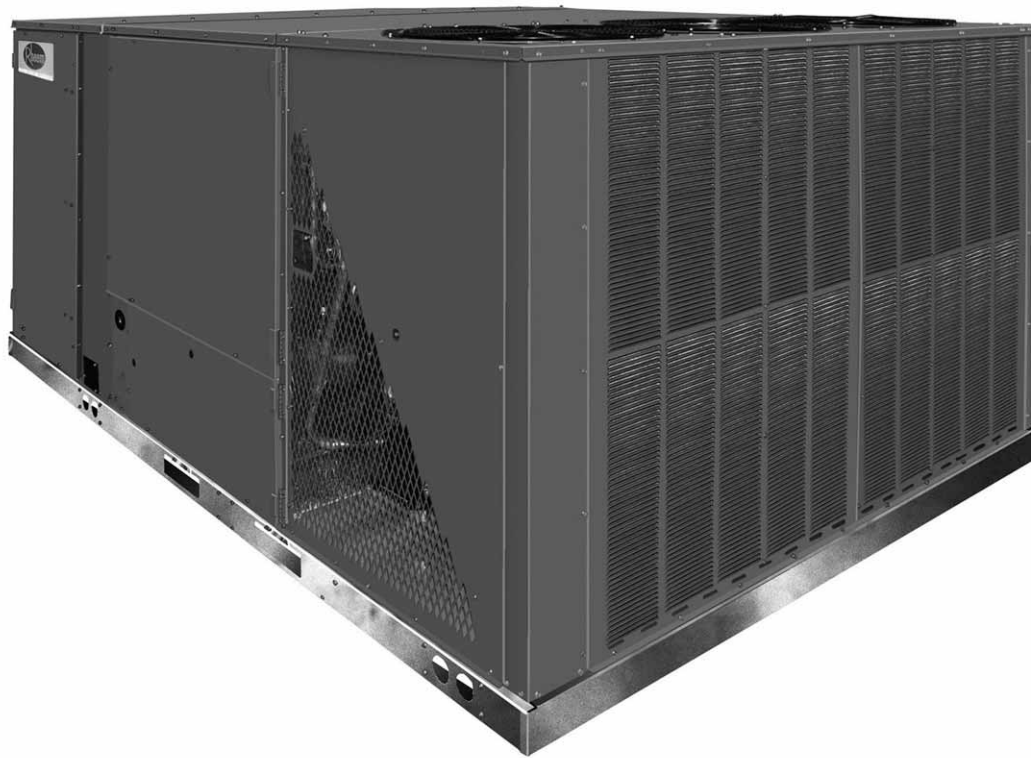

STANDARD FEATURES INCLUDE:

- R-410A HFC refrigerant.
- Complete factory charged, wired and run tested.
- Scroll compressors with internal line break overload and high-pressure protection.
- Two independent refrigerant circuits each with a scroll compressor provide two stage cooling operation.
- Convertible airflow – vertical downflow or horizontal sideflow.
- Capillary tube metering system on each circuit.
- High Pressure and Low Pressure/Loss of charge protection standard on all models.
- Solid Core liquid line filter drier on each circuit.
- Single slab, single pass designed evaporator and condenser coils facilitate easy cleaning for maintaining high efficiencies.
- Cooling operation up to 125 degree F ambient.
- Foil faced insulation encapsulated throughout entire unit minimizes airborne fibers from the air stream.
- Hinged major access door with heavy-duty gasketing.
- Slide Out Indoor fan assembly for added service convenience.
- Powder Paint Finish meets ASTM B117 steel coated on each side for maximum protection. G90 galvanized.
- Base pan with drawn supply and return opening for superior water management.
- Forkable base rails for easy handling and lifting.
- Single point electrical connections.
- Internally sloped slide out condensate pan conforms to ASHRAE 62 standards.
- High performance belt drive motor with variable pitch pulleys and quick adjust belt system.
- Permanently lubricated evaporator and condenser motors.
- Condenser motors are internally protected, totally enclosed with shaft down design.
- 2 inch filter standard with slide out design.
- 24 volt control system with resettable circuit breakers.
- Colored and labeled wiring.
- Copper tube/Aluminum Fin indoor coil.
- Aluminum MicroChannel outdoor coil(s).
- Supplemental electric heat provides 100% efficient heating.

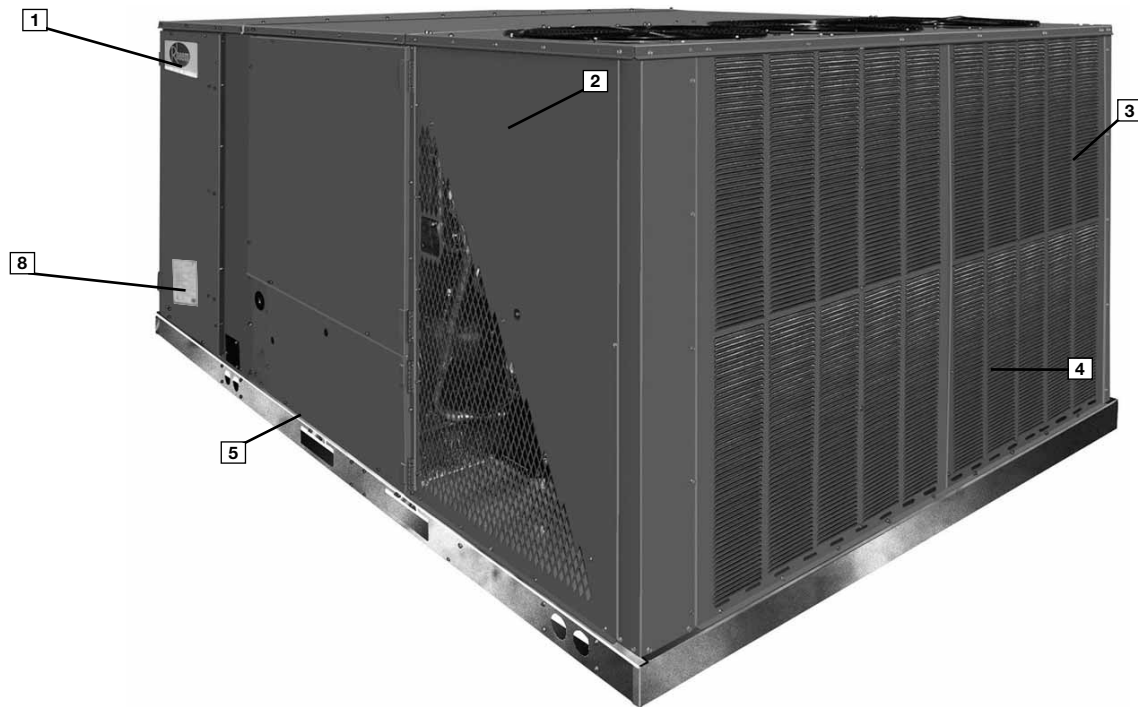

Rheem Package equipment is designed from the ground up with the latest features and benefits required to compete in today's market. The clean design stands alone in the industry and is a testament to the quality, reliability, ease of installation and serviceability that goes into each unit. Outwardly, the large Rheem *Commercial Series*™ label (1) identifies the brand to the customer. The sheet-metal cabinet (2) uses nothing less than 20-gauge material for structural components with an underlying coat of G90. To ensure the leak-proof integrity of these units, the design utilizes a top with a 1/8" drip lip (3), gasket-protected panels and screws. The (optional) hail guard protects the coil from hail damage (4). Every Rheem package unit uses the toughest finish in the industry, using electro deposition baked-on enamel tested to withstand a rigorous 1000-hour salt spray test, per ASTM B117.

Anything built to last must start with the right foundation. In this case, the foundation is 14-gauge, commercial-grade, full-perimeter base rails (5), which integrate fork slots and rigging holes to save set-up time on the job site. The base pan is stamped, which forms a 1-1/8" flange around the supply and return cover and has eliminated the worry of water entering the conditioned space (6). The drainpan (7) is made of material that resists the growth of harmful bacteria and is sloped for the latest IAQ benefits. Furthermore, the drain pan slides out for easy cleaning. The insulation has been placed on the underside of the basepan, removing areas that would allow for potential moisture accumulation, which can facilitate growth of harmful bacteria. All insulation is secured with both adhesive and mechanical fasteners, and all edges are hidden.

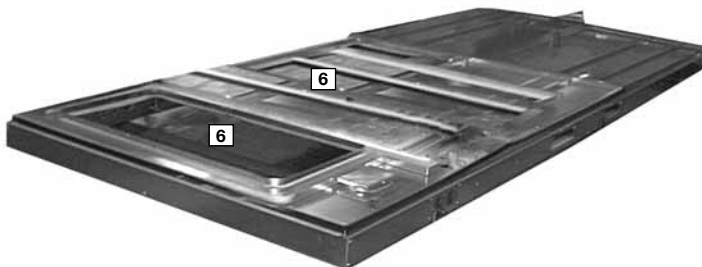

During development, each unit was tested to U.L. 1995, AHRI 340-360 and other Rheem-required reliability tests. Rheem adheres to stringent ISO 9002 quality procedures, and each unit bears the U.L. and AHRI certification labels located on the unit nameplate (8). Contractors can rest assured that when a Rheem package unit arrives at the job, it is ready to go with a factory charge and quality checks.

Access to all major compartments is from the front of the unit, including the filter and electrical compartment, blower compartment, heating section, and outdoor section. Each panel is permanently embossed with the compartment name (control/filter access, blower access and furnace access).

Electrical and filter compartment access is through a large, hinged-access panel. On the outside of the panel is the unit nameplate, which contains the model and serial number, electrical data and other important unit information.

The unit charging chart is located on the inside of the electrical and filter compartment door. Electrical wiring diagrams are found on the control box cover, which allows contractors to move them to more readable locations. To the right of the control box the model and serial number can be found. Having this information on the inside will assure model identification for the life of the product. The production line quality test assurance label is also placed in this location (9). The two-inch throwaway filters (10) are easily removed on a tracked system for easy replacement.

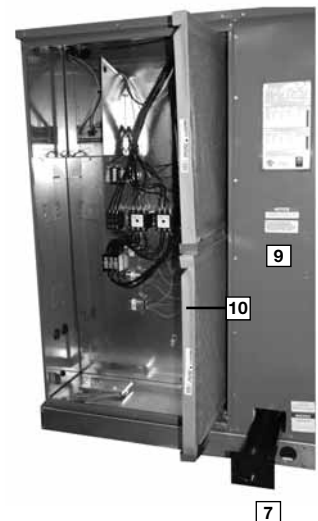

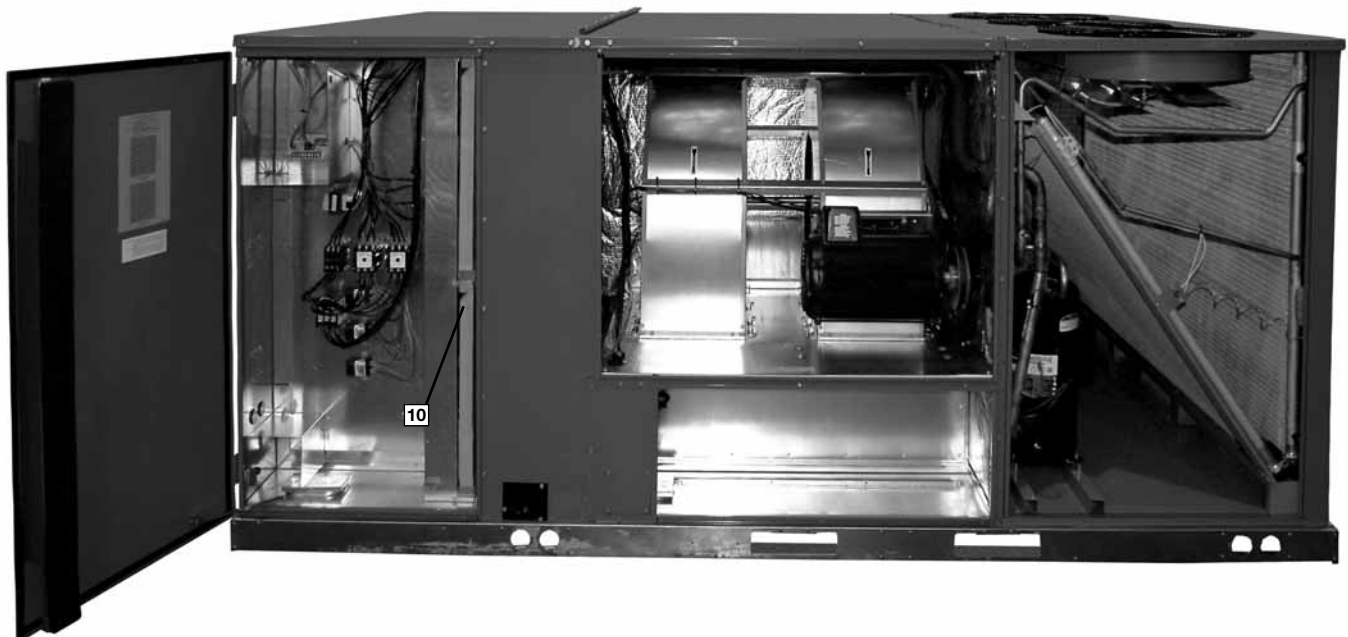

Inside the control box (11), each electrical component is clearly identified with a label that matches the component to the wire diagram for ease of trouble shooting. All wiring is numbered on each end of the termination and color-coded to match the wiring diagram. The control transformer has a low voltage circuit breaker that trips if a low voltage electrical short occurs. There is a blower contactor and contactor for each compressor.

For added convenience in the field, a factory-installed convenience outlet (12) is available. Low and High voltage can enter either from the side or through the base. Low-voltage connections are made through the low-voltage terminal strip. For ease of access, the U.L.-required low voltage barrier can be temporarily removed for low-voltage termination and then reinstalled. The high-voltage connection is terminated at the high voltage terminal block. The suggested mounting for the field-installed disconnect is on the exterior side of the electrical control box.



The blower compartment is to the right of the control box and can be accessed by 1/4 turn latches. To allow easy maintenance of the blower assembly, the entire assembly easily slides out by removing four #10 screws from the blower assembly. The adjustable motor pulley (13) can easily be adjusted by loosening the bolts on either side of the motor mount. Removing the bolts allows for easy removal of the blower pulley by pushing the blower assembly up to loosen the belt. Once the pulley is removed, the motor sheave can be adjusted to the desired number of turns, ranging from 0 to 6 turns open. Where the demands for the job require high static, Rheem has high-static drives available that deliver nominal airflow up to 2" of static. By referring to the airflow performance tables listed in the installation instructions, proper static pressure and CFM requirements can be dialed in. The scroll housing (14) and blower scroll provide quiet and efficient airflow. The blower sheave is secured by an "H" bushing which firmly secures the pulley to the blower shaft for years of trouble-free operation. The "H" bushing allows for easy removal of the blower pulley from the shaft, as opposed to the use of a set screw, which can score the shaft, creating burrs that make blower-pulley removal difficult.





Also inside the blower compartment are the optional low-ambient controls (15). The optional low-ambient controls allow for operation of the compressors down to 0 degrees ambient temperature by cycling the outdoor fans on high pressure.



Inside the blower compartment the interlaced evaporator can also be viewed. The evaporator uses enhanced fin technology for maximum heat transfer. The capillary tube metering device assures even distribution of refrigerant throughout the evaporator.

Wiring throughout the unit is neatly bundled and routed. Where wire harnesses go through the condenser bulkhead or blower deck, a molded wire harness assembly (16) provides an airtight and water-tight seal, and provides strain relief. Care is also taken to tuck raw edges of insulation behind sheet metal to improve indoor air quality.

The heating compartment contains the latest electric furnace technology on the market. The 100% efficient electric furnace can be factory-installed or easily field-installed. Built with ease-of-installation in mind, the electric furnace is completely wired up for slide-in, plug-and-play installation in the field. With choices of up to four kilowatt offerings, the contractor is assured to get the correct amount of heating output to meet the designed heating load.

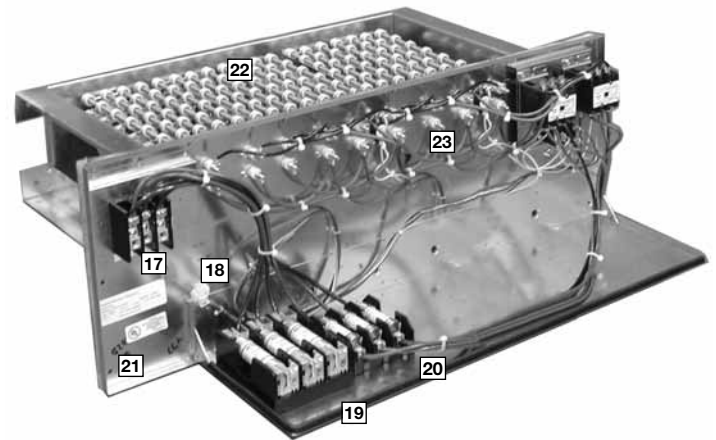

Power hook-up in the field is easy with single-point wiring to a terminal block (17) and a polarized plug for the low-voltage connection (18). The electric furnace comes with fuses for the unit (19) and for the electric furnace (20), and is UL certified (21). The electric heating elements are of a wound-wire construction (22) and isolated with ceramic bushings. The limit switch (23) protects the design from over-temperature conditions.

The compressor compartment houses the heartbeat of the unit. The scroll compressor (24) is known for its long life, and for reliable, quiet, and efficient operation. The suction and discharge lines are designed with shock loops (25) to absorb the strain and stress that the starting torque, steady state operation, and shut down cycle impose on the refrigerant tubing. Each compressor and circuit is independent for built-in redundancy, and each circuit is clearly marked throughout the system. Each unit has two stages of efficient cooling operation, first stage is approximately 50% of second stage.



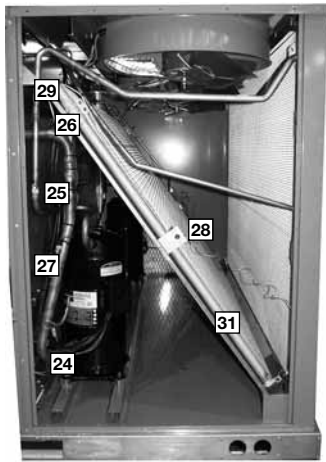

In the outdoor section are the external gauge ports (26). With the gauge ports mounted externally, an accurate diagnosis of system operation can be performed quickly and easily. Also located in this area are the refrigerant safety devices: the low-pressure switches (27), high-pressure switches (28) and the optional freeze-stats (29). The high-pressure switches will shut off the compressors if pressures exceeding 610 psig are detected as may occur if the outdoor fan motor fails. The low pressure switches shut off the compressors if low pressure is detected due to loss of refrigerant charge. The optional freeze-stats protect the compressors if the evaporator gets too cold (below freezing) due to low airflow. The factory-installed high and low pressure switches are brazed into the appropriate high or low side and wired appropriately. The optional freezestats clip on the suction lines above the compressors and connect to the low voltage circuit with the use of polarized plugs and a removable jumper for easy field or factory installation.

The condenser fan motor (30) can easily be accessed and maintained by removing the protective fan grille. The polarized plug connection allows the motor to be changed quickly and eliminates the need to snake wires through the unit.

The aluminum MicroChannel outdoor coil uses the latest enhanced fin design (31) for the most effective method of heat transfer with a reduction in refrigerant charge and unit weight. The outdoor coil is protected by optional louvered panels, which allow unobstructed airflow while protecting the unit from both Mother Nature and vandalism.

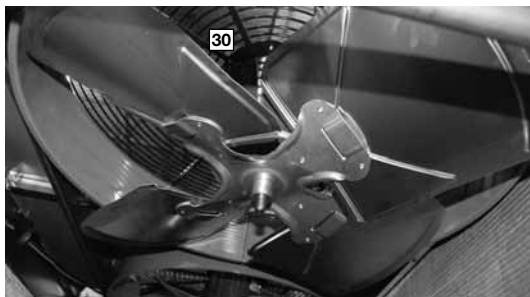

Each unit is designed for both downflow or horizontal applications (32) for job configuration flexibility. The return air compartment can also contain an economizer (33). Two models exist, one for downflow applications, and one for horizontal applications. Each unit is pre-wired for the economizer to allow quick plug-in installation. The downflow economizer is also available as a factory-installed option. Power Exhaust is easily field-installed. The economizer, which provides free cooling when outdoor conditions are suitable and also provides fresh air to meet local requirements, comes standard with single enthalpy controls. The controls can be upgraded to dual enthalpy easily in the field. The direct drive actuator combined with gear drive dampers has eliminated the need for linkage adjustment in the field. The economizer control has a minimum position setpoint, an outdoor-air setpoint, a mix-air setpoint, and a CO₂ setpoint. Barometric relief is standard on all economizers. The power exhaust is housed in the barometric relief opening and is easily slipped in with a plug-in assembly.

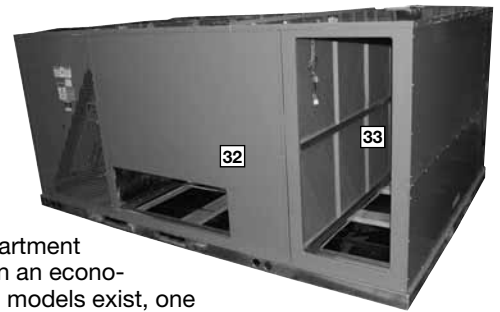

The Rheem roofcurb (34) is made for toolless assembly at the jobsite by inserting a pin into the hinged corners (35), which makes the assembly process quick and easy.

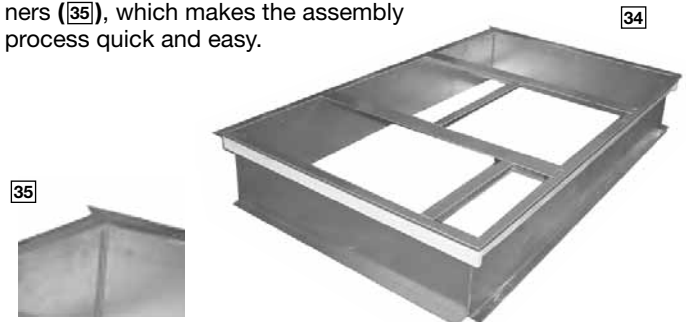



To select an RLKL-B Cooling and Heating unit to meet a job requirement, follow this procedure, with example, using data supplied in this specification sheet.

1. DETERMINE COOLING AND HEATING REQUIREMENTS AND SPECIFIC OPERATING CONDITIONS FROM PLANS AND SPECS.

Example:

Voltage—	240V—3 Phase—60 Hz
Total Cooling Capacity—	205,000 BTUH [60.0 kW]
Sensible Cooling Capacity—	155,000 BTUH [45.4 kW]
Heating Capacity—	235,000 BTUH [68.8 kW]
*Condenser Entering Air—	95°F [35.0°C] DB
*Evaporator Mixed Air Entering—	65°F [18.3°C] WB; 78°F [25.6°C] DB
*Indoor Air Flow (vertical)—	7200 CFM [3398 L/s]
*External Static Pressure—	.70 in. WG [.17 kPa]

2. SELECT UNIT TO MEET COOLING REQUIREMENTS.

Since total cooling is within the range of a nominal 20 ton [70.3 kW] unit, enter cooling performance table at 95°F [35.0 °C] DB condenser inlet air. Interpolate between 63°F [17.2 °C] WB and 67°F [19.4 °C] WB to determine total and sensible capacity and power input for 65°F [18.3 °C] WB evaporator inlet air at 7825 CFM [3692 L/s] indoor air flow (table basis):

Total Cooling Capacity = 245,500 BTUH [71.88 kW]
Sensible Cooling Capacity = 201,150 BTUH [58.90 kW]
Power Input (Compressor and Cond. Fans) = 19,750 watts

Use formula in note (1) to determine sensible capacity at 78°F [25.6 °C] DB evaporator entering air:

$201,150 + (1.10 \times 7,200 \times (1 - 0.11) \times (78 - 80))$
Sensible Cooling Capacity = 187,052 BTUH [54.77 kW]

3. CORRECT CAPACITIES OF STEP 2 FOR ACTUAL AIR FLOW.

Select factors from airflow correction table at 7200 CFM [3398 L/s] and apply to data obtained in step 2 to obtain gross capacity:

Total Capacity = $245,500 \times 0.99 = 243,045$ BTUH [71.17 kW]
Sensible Capacity = $187,052 \times 0.95 = 177,699$ BTUH [52.03 kW]
Power Input = $19,750 \times 0.99 = 19,553$ Watts

These are Gross Capacities, not corrected for blower motor heat or power.

4. DETERMINE BLOWER SPEED AND WATTS TO MEET SYSTEM DESIGN.

Enter Indoor Blower performance table at 7200 CFM [3398 L/s]. Total ESP (external static pressure) per the spec of 0.70 in. WG [.17 kPa] includes the system duct and grilles. Add from the table “Component Air Resistance”, 0.01 in. WG [.00 kPa] for wet coil, 0.08 in. WG [.02 kPa] for downflow air flow, for a total selection static pressure of 0.79 (0.8) in. WG [.20 kPa], and determine:

RPM = 741
WATTS = 2,895
DRIVE = L (standard 5 H.P. motor)

5. CALCULATE INDOOR BLOWER BTUH HEAT EFFECT FROM MOTOR WATTS, STEP 4.

$$2,895 \times 3.412 = 9,878 \text{ BTUH [2.89 kW]}$$

6. CALCULATE NET COOLING CAPACITIES, EQUAL TO GROSS CAPACITY, STEP 3, MINUS INDOOR BLOWER MOTOR HEAT.

$$\begin{aligned} \text{Net Total Capacity} &= 243,045 - 9,878 = \\ &233,167 \text{ BTUH [68.27 kW]} \\ \text{Net Sensible Capacity} &= 177,699 - 9,878 = \\ &167,821 \text{ BTUH [49.14 kW]} \end{aligned}$$

7. CALCULATE UNIT INPUT AND JOB EER.

$$\begin{aligned} \text{Total Power Input} &= 19,553 \text{ (step 3)} + 2,895 \\ &\text{(step 4)} = 22,448 \text{ Watts} \end{aligned}$$

$$\text{EER} = \frac{\text{Net Total BTUH [kW]} \text{ (step 6)}}{\text{Power Input, Watts (above)}} = \frac{233,167}{22,448} = 10.39$$

8. SELECT UNIT HEATING CAPACITY.

From Heater Kit Table select kW to meet heating capacity requirement; multiply kW x 3412 to convert to BTUH

Use 75 kW Heater Kit
Heater Kit Model: RXJJ-CE75C
Heater Kit Capacity: 245,323 BTUH [71.8 kW]

Add indoor blower heat effect (STEP 5) to Heater Kit Capacity to get total heating capacity:

$$245,323 + 9,878 = 255,201 \text{ BTUH [74.7 kW]}$$

9. CHOOSE MODEL RLKL-B240CL075

*NOTE: These operating conditions are typical of a commercial application in a 95°F/79°F [35°C/26°C] design area with indoor design of 76°F [24°C] DB and 50% RH and 10% ventilation air, with the unit roof mounted and centered on the zone it conditions by ducts.

[] Designates Metric Conversions





R L K L — B 180 C L 000 X X X



[] Designates Metric Conversions

FACTORY INSTALLED OPTION CODES FOR RLKL- (15 & 20 TON) [52.8 & 70.3 kW] (B180 & B240)

Option Code	Hail Guard	Non-Powered Convenience Outlet	Low Ambient / Freeze Stat
AD	X		
AG		X	
AP			X
BJ	X	X	
BY	X		X
JC		X	X
CX	X	X	X

Example: RLKL-B180CL000XXX (where XX is factory installed option)

Example: No Options

RLKL-B180CL000

Example: No Options with factory installed economizer

RLKL-B180CL000AAF

Example: Options with low ambient/freezestat and no factory installed economizer

RLKL-B180CL000APA

Example: Options same as above with factory installed economizer

RLKL-B180CL000APF

ECONOMIZER SELECTION FOR RLKL- (B180 & B240)

Option Code	No Economizer	Single Enthalpy Economizer* With Barometric Relief	Single Enthalpy Economizer* With Barometric Relief and Smoke Detector
A	X		
F		X	
G			X

"x" indicates factory installed option.

*Downflow economizer only.

Instructions for Factory Installed Option(s) Selection

Note: Three characters following the model number will be utilized to designate a factory-installed option or combination of options. If no factory option(s) is required, nothing follows the model number.

Step 1. After a basic rooftop model is selected, choose a *two-character* option code from the FACTORY INSTALLED OPTION SELECTION TABLE.

Proceed to Step 2.

Step 2. The last option code character is utilized for factory-installed economizers. Choose a character from the FACTORY INSTALLED ECONOMIZER SELECTION TABLE.

[] Designates Metric Conversions

NOM. SIZES 15 & 20 TONS [52.8 & 70.3]

Model RLKL- Series	B180CL	B180CM	B180DL	B180DM
Cooling Performance¹				CONTINUED →
Gross Cooling Capacity Btu [kW]	174,000 [50.98]	174,000 [50.98]	174,000 [50.98]	174,000 [50.98]
EER/SEER ²	11/NA	11/NA	11/NA	11/NA
Nominal CFM/AHRI Rated CFM [L/s]	6000/5500 [2831/2595]	6000/5500 [2831/2595]	6000/5500 [2831/2595]	6000/5500 [2831/2595]
AHRI Net Cooling Capacity Btu [kW]	170,000 [49.81]	170,000 [49.81]	170,000 [49.81]	170,000 [49.81]
Net Sensible Capacity Btu [kW]	125,400 [36.74]	125,400 [36.74]	125,400 [36.74]	125,400 [36.74]
Net Latent Capacity Btu [kW]	44,600 [13.07]	44,600 [13.07]	44,600 [13.07]	44,600 [13.07]
IEER ³	11.1	11.1	11.1	11.1
Net System Power [kW]	15.45	15.45	15.45	15.45
Compressor				
No./Type	2/Scroll	2/Scroll	2/Scroll	2/Scroll
Outdoor Sound Rating (dB)⁴	91	91	91	91
Outdoor Coil—Fin Type	Louvered	Louvered	Louvered	Louvered
Tube Type	MicroChannel	MicroChannel	MicroChannel	MicroChannel
MicroChannel Depth In. [mm]	1 [25.4]	1 [25.4]	1 [25.4]	1 [25.4]
Face Area sq. ft. [sq. m]	27.46 [2.55]	27.46 [2.55]	27.46 [2.55]	27.46 [2.55]
Rows / FPI [FPcm]	1 / 23 [9]	1 / 23 [9]	1 / 23 [9]	1 / 23 [9]
Indoor Coil—Fin Type	Louvered	Louvered	Louvered	Louvered
Tube Type	Rifled	Rifled	Rifled	Rifled
Tube Size in. [mm]	0.375 [9.5]	0.375 [9.5]	0.375 [9.5]	0.375 [9.5]
Face Area sq. ft. [sq. m]	26.67 [2.48]	26.67 [2.48]	26.67 [2.48]	26.67 [2.48]
Rows / FPI [FPcm]	2 / 18 [7]	2 / 18 [7]	2 / 18 [7]	2 / 18 [7]
Refrigerant Control	Capillary Tubes	Capillary Tubes	Capillary Tubes	Capillary Tubes
Drain Connection No./Size in. [mm]	1/1 [25.4]	1/1 [25.4]	1/1 [25.4]	1/1 [25.4]
Outdoor Fan—Type	Propeller	Propeller	Propeller	Propeller
No. Used/Diameter in. [mm]	3/24 [609.6]	3/24 [609.6]	3/24 [609.6]	3/24 [609.6]
Drive Type/No. Speeds	Direct/1	Direct/1	Direct/1	Direct/1
CFM [L/s]	10000 [4719]	10000 [4719]	10000 [4719]	10000 [4719]
No. Motors/HP	3 at 1/2 HP	3 at 1/2 HP	3 at 1/2 HP	3 at 1/2 HP
Motor RPM	1075	1075	1075	1075
Indoor Fan—Type	FC Centrifugal	FC Centrifugal	FC Centrifugal	FC Centrifugal
No. Used/Diameter in. [mm]	2/18x9 [457x229]	2/18x9 [457x229]	2/18x9 [457x229]	2/18x9 [457x229]
Drive Type/No. Speeds	Belt/Variable	Belt/Variable	Belt/Variable	Belt/Variable
No. Motors	1	1	1	1
Motor HP	3	5	3	5
Motor RPM	1725	1725	1725	1725
Motor Frame Size	56	184	56	184
Filter—Type	Disposable	Disposable	Disposable	Disposable
Furnished	Yes	Yes	Yes	Yes
(NO.) Size Recommended in. [mm x mm x mm]	(8)2x25x20 [51x635x508]	(8)2x25x20 [51x635x508]	(8)2x25x20 [51x635x508]	(8)2x25x20 [51x635x508]
Refrigerant Charge Oz. [g]	115/119 [3260/3374]	115/119 [3260/3374]	115/119 [3260/3374]	115/119 [3260/3374]
Weights				
Net Weight lbs. [kg]	1667 [756]	1696 [769]	1667 [756]	1696 [769]
Ship Weight lbs. [kg]	1794 [814]	1823 [827]	1794 [814]	1823 [827]

See Page 15 for Notes.

[] Designates Metric Conversions

NOM. SIZES 15 & 20 TONS [52.8 & 70.3]

Model RLKL- Series	B180YL	B180YM	B240CL	B240CM
Cooling Performance¹				
Gross Cooling Capacity Btu [kW]	174,000 [50.98]	174,000 [50.98]	250,000 [73.25]	250,000 [73.25]
EER/SEER ²	11/NA	11/NA	10.5/NA	10.5/NA
Nominal CFM/AHRI Rated CFM [L/s]	6000/5500 [2831/2595]	6000/5500 [2831/2595]	8000/7825 [3775/3693]	8000/7825 [3775/3693]
AHRI Net Cooling Capacity Btu [kW]	170,000 [49.81]	170,000 [49.81]	240,000 [70.32]	240,000 [70.32]
Net Sensible Capacity Btu [kW]	125,400 [36.74]	125,400 [36.74]	175,000 [51.27]	175,000 [51.27]
Net Latent Capacity Btu [kW]	44,600 [13.07]	44,600 [13.07]	65,000 [19.04]	65,000 [19.04]
IEER ³	11.1	11.1	10.5	10.5
Net System Power [kW]	15.45	15.45	22.88	22.88
Compressor				
No./Type	2/Scroll	2/Scroll	2/Scroll	2/Scroll
Outdoor Sound Rating (dB)⁴				
	91	91	91	91
Outdoor Coil—Fin Type				
Tube Type	Louvered	Louvered	Louvered	Louvered
MicroChannel Depth In. [mm]	MicroChannel	MicroChannel	MicroChannel	MicroChannel
Face Area sq. ft. [sq. m]	1 [25.4]	1 [25.4]	1 [25.4]	1 [25.4]
Rows / FPI [FPcm]	27.46 [2.55]	27.46 [2.55]	50.8 [4.72]	50.8 [4.72]
	1 / 23 [9]	1 / 23 [9]	1 / 23 [9]	1 / 23 [9]
Indoor Coil—Fin Type				
Tube Type	Louvered	Louvered	Louvered	Louvered
Tube Size in. [mm]	Rifled	Rifled	Rifled	Rifled
Face Area sq. ft. [sq. m]	0.375 [9.5]	0.375 [9.5]	0.375 [9.5]	0.375 [9.5]
Rows / FPI [FPcm]	26.67 [2.48]	26.67 [2.48]	26.67 [2.48]	26.67 [2.48]
Refrigerant Control	2 / 18 [7]	2 / 18 [7]	3 / 13 [5]	3 / 13 [5]
Drain Connection No./Size in. [mm]	Capillary Tubes	Capillary Tubes	Capillary Tubes	Capillary Tubes
	1/1 [25.4]	1/1 [25.4]	1/1 [25.4]	1/1 [25.4]
Outdoor Fan—Type				
No. Used/Diameter in. [mm]	Propeller	Propeller	Propeller	Propeller
Drive Type/No. Speeds	3/24 [609.6]	3/24 [609.6]	3/24 [609.6]	3/24 [609.6]
CFM [L/s]	Direct/1	Direct/1	Direct/1	Direct/1
No. Motors/HP	10000 [4719]	10000 [4719]	10000 [4719]	10000 [4719]
Motor RPM	3 at 1/2 HP	3 at 1/2 HP	3 at 1/2 HP	3 at 1/2 HP
	1075	1075	1075	1075
Indoor Fan—Type				
No. Used/Diameter in. [mm]	FC Centrifugal	FC Centrifugal	FC Centrifugal	FC Centrifugal
Drive Type/No. Speeds	2/18x9 [457x229]	2/18x9 [457x229]	2/18x9 [457x229]	2/18x9 [457x229]
No. Motors	Belt/Variable	Belt/Variable	Belt/Variable	Belt/Variable
Motor HP	1	1	1	1
Motor RPM	3	5	5	7 1/2
Motor Frame Size	1725	1725	1725	1725
	56	184	184	213
Filter—Type				
Furnished	Disposable	Disposable	Disposable	Disposable
(NO.) Size Recommended in. [mm x mm x mm]	Yes	Yes	Yes	Yes
	(8)2x25x20 [51x635x508]	(8)2x25x20 [51x635x508]	(8)2x25x20 [51x635x508]	(8)2x25x20 [51x635x508]
Refrigerant Charge Oz. [g]				
	115/119 [3260/3374]	115/119 [3260/3374]	200/219 [5670/6209]	200/219 [5670/6209]
Weights				
Net Weight lbs. [kg]	1667 [756]	1696 [769]	1883 [854]	1921 [871]
Ship Weight lbs. [kg]	1794 [814]	1823 [827]	2009 [911]	2047 [929]

See Page 15 for Notes.

[] Designates Metric Conversions

NOM. SIZES 15 & 20 TONS [52.8 & 70.3]

Model RLKL- Series	B240CN	B240DL	B240DM	B240DN
Cooling Performance¹				CONTINUED →
Gross Cooling Capacity Btu [kW]	250,000 [73.25]	250,000 [73.25]	250,000 [73.25]	250,000 [73.25]
EER/SEER ²	10.5/NA	10.5/NA	10.5/NA	10.5/NA
Nominal CFM/AHRI Rated CFM [L/s]	8000/7825 [3775/3693]	8000/7825 [3775/3693]	8000/7825 [3775/3693]	8000/7825 [3775/3693]
AHRI Net Cooling Capacity Btu [kW]	240,000 [70.32]	240,000 [70.32]	240,000 [70.32]	240,000 [70.32]
Net Sensible Capacity Btu [kW]	175,000 [51.27]	175,000 [51.27]	175,000 [51.27]	175,000 [51.27]
Net Latent Capacity Btu [kW]	65,000 [19.04]	65,000 [19.04]	65,000 [19.04]	65,000 [19.04]
IEER ³	10.5	10.5	10.5	10.5
Net System Power [kW]	22.88	22.88	22.88	22.88
Compressor				
No./Type	2/Scroll	2/Scroll	2/Scroll	2/Scroll
Outdoor Sound Rating (dB)⁴	91	91	91	91
Outdoor Coil—Fin Type	Louvered	Louvered	Louvered	Louvered
Tube Type	MicroChannel	MicroChannel	MicroChannel	MicroChannel
MicroChannel Depth In. [mm]	1 [25.4]	1 [25.4]	1 [25.4]	1 [25.4]
Face Area sq. ft. [sq. m]	50.8 [4.72]	50.8 [4.72]	50.8 [4.72]	50.8 [4.72]
Rows / FPI [FPcm]	1 / 23 [9]	1 / 23 [9]	1 / 23 [9]	1 / 23 [9]
Indoor Coil—Fin Type	Louvered	Louvered	Louvered	Louvered
Tube Type	Rifled	Rifled	Rifled	Rifled
Tube Size in. [mm]	0.375 [9.5]	0.375 [9.5]	0.375 [9.5]	0.375 [9.5]
Face Area sq. ft. [sq. m]	26.67 [2.48]	26.67 [2.48]	26.67 [2.48]	26.67 [2.48]
Rows / FPI [FPcm]	3 / 13 [5]	3 / 13 [5]	3 / 13 [5]	3 / 13 [5]
Refrigerant Control	Capillary Tubes	Capillary Tubes	Capillary Tubes	Capillary Tubes
Drain Connection No./Size in. [mm]	1/1 [25.4]	1/1 [25.4]	1/1 [25.4]	1/1 [25.4]
Outdoor Fan—Type	Propeller	Propeller	Propeller	Propeller
No. Used/Diameter in. [mm]	3/24 [609.6]	3/24 [609.6]	3/24 [609.6]	3/24 [609.6]
Drive Type/No. Speeds	Direct/1	Direct/1	Direct/1	Direct/1
CFM [L/s]	10000 [4719]	10000 [4719]	10000 [4719]	10000 [4719]
No. Motors/HP	3 at 1/2 HP	3 at 1/2 HP	3 at 1/2 HP	3 at 1/2 HP
Motor RPM	1075	1075	1075	1075
Indoor Fan—Type	FC Centrifugal	FC Centrifugal	FC Centrifugal	FC Centrifugal
No. Used/Diameter in. [mm]	2/18x9 [457x229]	2/18x9 [457x229]	2/18x9 [457x229]	2/18x9 [457x229]
Drive Type/No. Speeds	Belt/Variable	Belt/Variable	Belt/Variable	Belt/Variable
No. Motors	1	1	1	1
Motor HP	7 1/2	5	7 1/2	7 1/2
Motor RPM	1725	1725	1725	1725
Motor Frame Size	213	184	184	184
Filter—Type	Disposable	Disposable	Disposable	Disposable
Furnished	Yes	Yes	Yes	Yes
(NO.) Size Recommended in. [mm x mm x mm]	(8)2x25x20 [51x635x508]	(8)2x25x20 [51x635x508]	(8)2x25x20 [51x635x508]	(8)2x25x20 [51x635x508]
Refrigerant Charge Oz. [g]	200/219 [5670/6209]	200/219 [5670/6209]	200/219 [5670/6209]	200/219 [5670/6209]
Weights				
Net Weight lbs. [kg]	1919 [870]	1883 [854]	1921 [871]	1919 [870]
Ship Weight lbs. [kg]	2046 [928]	2009 [911]	2047 [929]	2046 [928]

See Page 15 for Notes.

[] Designates Metric Conversions

NOM. SIZES 15 & 20 TONS [52.8 & 70.3]

Model RLKL- Series	B240YL	B240YM	B240YN
Cooling Performance¹			
Gross Cooling Capacity Btu [kW]	250,000 [73.25]	250,000 [73.25]	250,000 [73.25]
EER/SEER ²	10.5/NA	10.5/NA	10.5/NA
Nominal CFM/AHRI Rated CFM [L/s]	8000/7825 [3775/3693]	8000/7825 [3775/3693]	8000/7825 [3775/3693]
AHRI Net Cooling Capacity Btu [kW]	240,000 [70.32]	240,000 [70.32]	240,000 [70.32]
Net Sensible Capacity Btu [kW]	175,000 [51.27]	175,000 [51.27]	175,000 [51.27]
Net Latent Capacity Btu [kW]	65,000 [19.04]	65,000 [19.04]	65,000 [19.04]
IEER ³	10.5	10.5	10.5
Net System Power [kW]	22.88	22.88	22.88
Compressor			
No./Type	2/Scroll	2/Scroll	2/Scroll
Outdoor Sound Rating (dB)⁴			
	91	91	91
Outdoor Coil—Fin Type			
Tube Type	Louvered	Louvered	Louvered
MicroChannel Depth In. [mm]	MicroChannel	MicroChannel	MicroChannel
Face Area sq. ft. [sq. m]	1 [25.4]	1 [25.4]	1 [25.4]
Rows / FPI [FPcm]	50.8 [4.72]	50.8 [4.72]	50.8 [4.72]
	1 / 23 [9]	1 / 23 [9]	1 / 23 [9]
Indoor Coil—Fin Type			
Tube Type	Louvered	Louvered	Louvered
Tube Size in. [mm]	Rifled	Rifled	Rifled
Face Area sq. ft. [sq. m]	0.375 [9.5]	0.375 [9.5]	0.375 [9.5]
Rows / FPI [FPcm]	26.67 [2.48]	26.67 [2.48]	26.67 [2.48]
Refrigerant Control	3 / 13 [5]	3 / 13 [5]	3 / 13 [5]
Drain Connection No./Size in. [mm]	Capillary Tubes	Capillary Tubes	Capillary Tubes
	1/1 [25.4]	1/1 [25.4]	1/1 [25.4]
Outdoor Fan—Type			
No. Used/Diameter in. [mm]	Propeller	Propeller	Propeller
Drive Type/No. Speeds	3/24 [609.6]	3/24 [609.6]	3/24 [609.6]
CFM [L/s]	Direct/1	Direct/1	Direct/1
No. Motors/HP	10000 [4719]	10000 [4719]	10000 [4719]
Motor RPM	3 at 1/2 HP	3 at 1/2 HP	3 at 1/2 HP
	1075	1075	1075
Indoor Fan—Type			
No. Used/Diameter in. [mm]	FC Centrifugal	FC Centrifugal	FC Centrifugal
Drive Type/No. Speeds	2/18x9 [457x229]	2/18x9 [457x229]	2/18x9 [457x229]
No. Motors	Belt/Variable	Belt/Variable	Belt/Variable
Motor HP	1	1	1
Motor RPM	5	7 1/2	7 1/2
Motor Frame Size	1725	1725	1725
	184	213	213
Filter—Type			
Furnished	Disposable	Disposable	Disposable
(NO.) Size Recommended in. [mm x mm x mm]	Yes	Yes	Yes
	(8)2x25x20 [51x635x508]	(8)2x25x20 [51x635x508]	(8)2x25x20 [51x635x508]
Refrigerant Charge Oz. [g]			
	200/219 [5670/6209]	200/219 [5670/6209]	200/219 [5670/6209]
Weights			
Net Weight lbs. [kg]	1883 [854]	1921 [871]	1919 [870]
Ship Weight lbs. [kg]	2009 [911]	2047 [929]	2046 [928]

See Page 15 for Notes.

[] Designates Metric Conversions

NOTES:

1. Cooling Performance is rated at 95° F ambient, 80° F entering dry bulb, 67° F entering wet bulb. Gross capacity does not include the effect of fan motor heat. AHRI capacity is net and includes the effect of fan motor heat. Units are suitable for operation to $\pm 20\%$ of nominal cfm. Units are certified in accordance with the Unitary Air Conditioner Equipment certification program, which is based on AHRI Standard 210/240 or 360.
2. EER and/or SEER are rated at AHRI conditions and in accordance with DOE test procedures.
3. IEER is rated in accordance with AHRI Standard 340/360.
4. Outdoor Sound Rating shown is tested in accordance with AHRI Standard 270.



GROSS SYSTEMS PERFORMANCE DATA—B180

ENTERING INDOOR AIR @ 80°F [26.7°C] dbE ①											
wbE		71°F [21.7°C]			67°F [19.4°C]			63°F [17.2°C]			
CFM [L/s]		7200 [3398]	5500 [2596]	4800 [2265]	7200 [3398]	5500 [2596]	4800 [2265]	7200 [3398]	5500 [2596]	4800 [2265]	
DR ①		0.05	0.11	0.14	0.05	0.11	0.14	0.05	0.11	0.14	
OUTDOOR DRY BULB TEMPERATURE [°C]	75 [23.9]	Total BTUH [kW] Sens BTUH [kW] Power	205.0 [60.1] 133.0 [39.0] 12.1	194.1 [56.9] 105.3 [30.9] 11.8	189.6 [55.6] 94.8 [27.8] 11.7	196.7 [57.6] 161.3 [47.3] 12.0	186.3 [54.6] 130.6 [38.3] 11.6	182.0 [53.3] 118.8 [34.8] 11.5	190.1 [55.7] 184.2 [54.0] 11.8	180.0 [52.8] 150.9 [44.2] 11.5	175.8 [51.5] 138.0 [40.5] 11.3
	80 [26.7]	Total BTUH [kW] Sens BTUH [kW] Power	202.7 [59.4] 133.8 [39.2] 12.7	191.9 [56.2] 106.1 [31.1] 12.4	187.4 [54.9] 95.6 [28.0] 12.2	194.4 [57.0] 162.1 [47.5] 12.5	184.1 [54.0] 131.4 [38.5] 12.2	179.8 [52.7] 119.6 [35.1] 12.1	187.7 [55.0] 184.9 [54.2] 12.4	177.7 [52.1] 151.6 [44.4] 12.0	173.6 [50.9] 138.7 [40.7] 11.9
	85 [29.4]	Total BTUH [kW] Sens BTUH [kW] Power	199.8 [58.6] 133.8 [39.2] 13.4	189.1 [55.4] 106.2 [31.1] 13.0	184.8 [54.2] 95.8 [28.1] 12.9	191.5 [56.1] 162.1 [47.5] 13.2	181.3 [53.1] 131.5 [38.5] 12.8	177.1 [51.9] 119.7 [35.1] 12.7	184.8 [54.2] 184.8 [54.2] 13.0	175.0 [51.3] 151.8 [44.5] 12.7	171.0 [50.1] 139.0 [40.7] 12.5
	90 [32.2]	Total BTUH [kW] Sens BTUH [kW] Power	196.3 [57.5] 132.8 [38.9] 14.0	185.9 [54.5] 105.7 [31.0] 13.7	181.6 [53.2] 95.4 [28.0] 13.5	188.1 [55.1] 161.3 [47.3] 13.9	178.1 [52.2] 131.0 [38.4] 13.5	174.0 [51.0] 119.4 [35.0] 13.3	181.4 [53.2] 181.4 [53.2] 13.7	171.8 [50.3] 151.3 [44.4] 13.3	167.8 [49.2] 138.6 [40.6] 13.2
	95 [35]	Total BTUH [kW] Sens BTUH [kW] Power	192.3 [56.4] 131.1 [38.4] 14.8	182.1 [53.4] 104.4 [30.6] 14.4	177.9 [52.1] 94.2 [27.6] 14.2	184.1 [54.0] 159.6 [46.8] 14.6	174.3 [51.1] 129.7 [38.0] 14.2	170.3 [49.9] 118.2 [34.7] 14.0	177.4 [52.0] 177.4 [52.0] 14.4	168.0 [49.2] 150.0 [44.0] 14.0	164.1 [48.1] 137.4 [40.3] 13.9
	100 [37.8]	Total BTUH [kW] Sens BTUH [kW] Power	187.8 [55.0] 128.6 [37.7] 15.5	177.8 [52.1] 102.4 [30.0] 15.1	173.7 [50.9] 92.5 [27.1] 14.9	179.6 [52.6] 157.2 [46.1] 15.3	170.0 [49.8] 127.8 [37.5] 14.9	166.1 [48.7] 116.5 [34.2] 14.8	172.9 [50.7] 172.9 [50.7] 15.2	163.7 [48.0] 148.1 [43.4] 14.8	159.9 [46.9] 135.7 [39.8] 14.6
	105 [40.6]	Total BTUH [kW] Sens BTUH [kW] Power	182.7 [53.5] 125.3 [36.7] 16.3	173.0 [50.7] 99.8 [29.3] 15.9	169.0 [49.5] 90.1 [26.4] 15.7	174.5 [51.1] 153.9 [45.1] 16.1	165.2 [48.4] 125.2 [36.7] 15.7	161.4 [47.3] 114.2 [33.5] 15.5	167.8 [49.2] 167.8 [49.2] 16.0	158.9 [46.6] 145.5 [42.7] 15.5	155.2 [45.5] 133.4 [39.1] 15.4
	110 [43.3]	Total BTUH [kW] Sens BTUH [kW] Power	177.1 [51.9] 121.3 [35.6] 17.1	167.7 [49.1] 96.6 [28.3] 16.7	163.8 [48.0] 87.2 [25.6] 16.5	168.8 [49.5] 149.7 [43.9] 17.0	159.8 [46.8] 121.8 [35.7] 16.5	156.1 [45.7] 111.1 [32.6] 16.3	162.2 [47.5] 162.2 [47.5] 16.8	153.5 [45.0] 142.1 [41.7] 16.4	150.0 [44.0] 130.4 [38.2] 16.2
	115 [46.1]	Total BTUH [kW] Sens BTUH [kW] Power	170.9 [50.1] 116.3 [34.1] 18.0	161.8 [47.4] 92.5 [27.1] 17.5	158.1 [46.3] 83.5 [24.5] 17.4	162.6 [47.7] 144.6 [42.4] 17.9	154.0 [45.1] 117.8 [34.5] 17.4	150.4 [44.1] 107.4 [31.5] 17.2	156.0 [45.7] 156.0 [45.7] 17.7	147.7 [43.3] 138.1 [40.5] 17.2	144.3 [42.3] 126.7 [37.1] 17.0

GROSS SYSTEMS PERFORMANCE DATA—B240

ENTERING INDOOR AIR @ 80°F [26.7°C] dbE ①											
wbE		71°F [21.7°C]			67°F [19.4°C]			63°F [17.2°C]			
CFM [L/s]		9600 [4531]	7825 [3693]	6400 [3020]	9600 [4531]	7825 [3693]	6400 [3020]	9600 [4531]	7825 [3693]	6400 [3020]	
DR ①		0.06	0.11	0.15	0.06	0.11	0.15	0.06	0.11	0.15	
OUTDOOR DRY BULB TEMPERATURE [°C]	75 [23.9]	Total BTUH [kW] Sens BTUH [kW] Power	295.2 [86.5] 188.5 [55.3] 17.0	283.5 [83.1] 158.8 [46.5] 16.6	274.1 [80.3] 136.7 [40.1] 16.4	281.3 [82.4] 226.4 [66.4] 16.7	270.2 [79.2] 193.6 [56.7] 16.4	261.3 [76.6] 169.0 [49.5] 16.1	271.4 [79.5] 261.1 [76.5] 16.4	260.6 [76.4] 225.3 [66.0] 16.1	252.0 [73.9] 198.3 [58.1] 15.8
	80 [26.7]	Total BTUH [kW] Sens BTUH [kW] Power	291.1 [85.3] 186.7 [54.7] 17.8	279.6 [81.9] 157.3 [46.1] 17.4	270.4 [79.2] 135.5 [39.7] 17.2	277.3 [81.3] 224.6 [65.8] 17.5	266.3 [78.0] 192.1 [56.3] 17.2	257.5 [75.5] 167.7 [49.2] 16.9	267.3 [78.3] 259.2 [76.0] 17.2	256.7 [75.2] 223.8 [65.6] 16.9	248.2 [72.7] 197.0 [57.7] 16.6
	85 [29.4]	Total BTUH [kW] Sens BTUH [kW] Power	286.3 [83.9] 184.3 [54.0] 18.7	275.0 [80.6] 155.4 [45.6] 18.3	265.9 [77.9] 133.9 [39.3] 18.0	272.5 [79.9] 222.3 [65.2] 18.4	261.7 [76.7] 190.2 [55.8] 18.0	253.0 [74.1] 166.1 [48.7] 17.7	262.5 [76.9] 256.9 [75.3] 18.1	252.1 [73.9] 221.9 [65.0] 17.7	243.7 [71.4] 195.4 [57.3] 17.4
	90 [32.2]	Total BTUH [kW] Sens BTUH [kW] Power	280.8 [82.3] 181.7 [53.3] 19.6	269.6 [79.0] 153.1 [44.9] 19.2	260.7 [76.4] 131.9 [38.7] 18.9	266.9 [78.2] 219.5 [64.3] 19.3	256.3 [75.1] 187.9 [55.1] 18.9	247.8 [72.6] 164.2 [48.1] 18.6	256.9 [75.3] 254.1 [74.5] 19.0	246.7 [72.3] 219.6 [64.4] 18.6	238.6 [69.9] 193.5 [56.7] 18.3
	95 [35]	Total BTUH [kW] Sens BTUH [kW] Power	274.4 [80.4] 178.4 [52.3] 20.6	263.6 [77.3] 150.5 [44.1] 20.2	254.9 [74.7] 129.7 [38.0] 19.8	260.6 [76.4] 216.3 [63.4] 20.3	250.3 [73.4] 185.3 [54.3] 19.9	242.0 [70.9] 162.0 [47.5] 19.6	250.6 [73.4] 250.6 [73.5] 20.0	240.7 [70.5] 217.0 [63.6] 19.6	232.7 [68.2] 191.2 [56.0] 19.3
	100 [37.8]	Total BTUH [kW] Sens BTUH [kW] Power	267.4 [78.4] 174.7 [51.2] 21.6	256.8 [75.3] 147.4 [43.2] 21.2	248.3 [72.8] 127.1 [37.3] 20.8	253.5 [74.3] 212.5 [62.3] 21.3	243.5 [71.4] 182.2 [53.4] 20.9	235.4 [69.0] 159.3 [46.7] 20.5	243.5 [71.4] 243.5 [71.4] 21.0	233.9 [68.5] 214.0 [62.7] 20.6	226.1 [66.3] 188.7 [55.3] 20.3
	105 [40.6]	Total BTUH [kW] Sens BTUH [kW] Power	259.6 [76.1] 170.6 [50.0] 22.7	249.3 [73.1] 144.0 [42.2] 22.2	241.0 [70.6] 124.2 [36.4] 21.9	245.7 [72.0] 208.5 [61.1] 22.4	236.0 [69.2] 178.8 [52.4] 21.9	228.2 [66.9] 156.5 [45.9] 21.6	235.7 [69.1] 235.7 [69.1] 22.1	226.4 [66.4] 210.5 [61.7] 21.7	218.9 [64.2] 185.7 [54.4] 21.3
	110 [43.3]	Total BTUH [kW] Sens BTUH [kW] Power	251.0 [73.6] 166.1 [48.7] 23.8	241.1 [70.7] 140.3 [41.1] 23.3	233.1 [68.3] 121.1 [35.5] 22.9	237.1 [69.5] 203.9 [59.8] 23.5	227.7 [66.7] 175.0 [51.3] 23.0	220.2 [64.5] 153.3 [44.9] 22.7	227.1 [66.6] 227.1 [66.6] 23.2	218.1 [63.9] 206.7 [60.6] 22.8	210.9 [61.8] 182.5 [53.5] 22.4
	115 [46.1]	Total BTUH [kW] Sens BTUH [kW] Power	241.7 [70.8] 161.0 [47.2] 25.0	232.1 [68.0] 136.0 [39.9] 24.5	224.4 [65.8] 117.4 [34.4] 24.1	227.8 [66.8] 198.8 [58.3] 24.7	218.8 [64.1] 170.8 [50.1] 24.2	211.5 [62.0] 149.6 [43.9] 23.8	217.8 [63.8] 217.8 [63.8] 24.4	209.2 [61.3] 202.5 [59.4] 23.9	202.3 [59.3] 179.0 [52.5] 23.5

DR —Depression ratio
dbE —Entering air dry bulb
wbE —Entering air wet bulb

Total —Total capacity x 1000 BTUH
Sens —Sensible capacity x 1000 BTUH
Power —KW input

NOTES: ① When the entering air dry bulb is other than 80°F [27°C], adjust the sensible capacity from the table by adding $[1.10 \times \text{CFM} \times (1 - \text{DR}) \times (\text{dbE} - 80)]$.

[] Designates Metric Conversions





AIRFLOW PERFORMANCE—15 TON [52.8 kW]—SIDEFLOW

Air Flow CFM [L/s]	Model RLKL-B180 Voltage 208/230, 460, 575 — 3 Phase 60 Hz																			
	External Static Pressure—Inches of Water [kPa]																			
	0.1 [0.02]	0.2 [0.05]	0.3 [0.07]	0.4 [0.10]	0.5 [0.12]	0.6 [0.15]	0.7 [0.17]	0.8 [0.20]	0.9 [0.22]	1.0 [0.25]	1.1 [0.27]	1.2 [0.30]	1.3 [0.32]	1.4 [0.35]	1.5 [0.37]	1.6 [0.40]	1.7 [0.42]	1.8 [0.45]	1.9 [0.47]	2.0 [0.50]
4800 [2265]	—	—	—	—	—	—	—	—	—	—	—	—	—	—	—	—	—	—	—	—
5000 [2359]	—	—	—	—	—	—	—	—	—	—	—	—	—	—	—	—	—	—	—	—
5200 [2454]	—	—	—	—	—	—	—	—	—	—	—	—	—	—	—	—	—	—	—	—
5400 [2548]	—	—	—	—	—	—	—	—	—	—	—	—	—	—	—	—	—	—	—	—
5600 [2643]	—	—	—	—	—	—	—	—	—	—	—	—	—	—	—	—	—	—	—	—
5800 [2737]	—	—	—	—	—	—	—	—	—	—	—	—	—	—	—	—	—	—	—	—
6000 [2831]	—	—	—	—	—	—	—	—	—	—	—	—	—	—	—	—	—	—	—	—
6200 [2926]	—	—	—	—	—	—	—	—	—	—	—	—	—	—	—	—	—	—	—	—
6400 [3020]	—	—	—	—	—	—	—	—	—	—	—	—	—	—	—	—	—	—	—	—
6600 [3114]	—	—	—	—	—	—	—	—	—	—	—	—	—	—	—	—	—	—	—	—
6800 [3209]	—	—	—	—	—	—	—	—	—	—	—	—	—	—	—	—	—	—	—	—
7000 [3303]	—	—	—	—	—	—	—	—	—	—	—	—	—	—	—	—	—	—	—	—
7200 [3398]	—	—	—	—	—	—	—	—	—	—	—	—	—	—	—	—	—	—	—	—

NOTE: L-Drive left of bold line, M-Drive right of bold line.

Drive Package	L						M					
Motor H.P. [W]	3.0 [2237.1]						5.0 [3728.5]					
Blower Sheave	BK105H						BK105H					
Motor Sheave	1V-44						1VP-56					
Turns Open	1	2	3	4	5	6	1	2	3	4	5	6
RPM	733	701	669	640	605	572	927	903	873	840	808	775

NOTES: 1. Factory sheave settings are shown in bold type.

2. Do not set motor sheave below minimum turns open shown.

3. Re-adjustment of sheave required to achieve rated airflow at AHRI minimum External Static Pressure.

4. Drive data shown is for horizontal airflow with dry coil. Add component resistance (below) to duct resistance to determine total External Static Pressure.

COMPONENT AIR RESISTANCE—15 TON [52.8 kW]

CFM [L/s]	Resistance — Inches of Water [kPa]												
	4800 [2265]	5000 [2359]	5200 [2454]	5400 [2548]	5600 [2643]	5800 [2737]	6000 [2831]	6200 [2926]	6400 [3020]	6600 [3114]	6800 [3209]	7000 [3303]	7200 [3398]
Wet Coil	0.03 [0.01]	0.04 [0.01]	0.05 [0.01]	0.06 [0.01]	0.06 [0.01]	0.07 [0.02]	0.08 [0.02]	0.09 [0.02]	0.10 [0.02]	0.10 [0.02]	0.11 [0.03]	0.12 [0.03]	0.13 [0.03]
Downflow	0.05 [0.01]	0.05 [0.01]	0.05 [0.01]	0.05 [0.01]	0.05 [0.01]	0.05 [0.01]	0.05 [0.01]	0.06 [0.01]	0.06 [0.01]	0.06 [0.01]	0.07 [0.02]	0.08 [0.02]	0.08 [0.02]
Downflow Economizer R.A. Damper Open	0.09 [0.02]	0.10 [0.02]	0.10 [0.02]	0.11 [0.03]	0.12 [0.03]	0.13 [0.03]	0.13 [0.03]	0.14 [0.03]	0.15 [0.04]	0.16 [0.04]	0.16 [0.04]	0.17 [0.04]	0.18 [0.04]
Horizontal Economizer R.A. Damper Open	0.00 [0.00]	0.01 [0.00]	0.01 [0.00]	0.02 [0.00]	0.02 [0.00]	0.03 [0.00]	0.03 [0.00]	0.04 [0.01]	0.04 [0.01]	0.05 [0.01]	0.05 [0.01]	0.06 [0.01]	0.06 [0.01]
Concentric Grill RXRN-AD80 or RXRN-AD81 & Transition RXMC-CJ07	0.21 [0.05]	0.25 [0.06]	0.28 [0.07]	0.32 [0.08]	0.35 [0.09]	0.39 [0.10]	0.43 [0.11]	0.46 [0.11]	0.50 [0.12]	0.54 [0.13]	0.57 [0.14]	0.61 [0.15]	0.64 [0.16]

NOTE: Add component resistance to duct resistance to determine total external static pressure.

AIRFLOW CORRECTION FACTORS—15 TON [52.8 kW]

ACTUAL—CFM [L/s]	4800 [2265]	5000 [2359]	5200 [2454]	5400 [2548]	5600 [2643]	5800 [2737]	6000 [2831]	6200 [2926]	6400 [3020]	6600 [3114]	6800 [3209]	7000 [3303]	7200 [3398]
TOTAL MBH	0.98	0.98	0.99	1.00	1.00	1.01	1.02	1.02	1.03	1.04	1.04	1.05	1.06
SENSIBLE MBH	0.91	0.94	0.96	0.99	1.02	1.04	1.07	1.10	1.12	1.15	1.18	1.20	1.23
POWER kW	0.99	0.99	0.99	1.00	1.00	1.00	1.01	1.01	1.01	1.02	1.02	1.02	1.03

NOTES: Multiply correction factor times gross performance data—resulting sensible capacity cannot exceed total capacity.

[] Designates Metric Conversions



ELECTRICAL DATA – RLKL- SERIES							
		B180CL	B180CM	B180DL	B180DM	B180YL	B180YM
Unit Information	Unit Operating Voltage Range	187-253	187-253	414-506	414-506	518-633	518-633
	Volts	208/230	208/230	460	460	575	575
	Minimum Circuit Ampacity	75/75	78/78	38	40	28	30
	Minimum Overcurrent Protection Device Size	90/90	90/90	45	45	30	35
	Maximum Overcurrent Protection Device Size	90/90	100/100	50	50	35	35
Compressor Motor	No.	2	2	2	2	2	2
	Volts	200/230	200/230	460	460	575	575
	Phase	3	3	3	3	3	3
	RPM	3450	3450	3450	3450	3450	3450
	HP, Compressor 1	7	7	7	7	7	7
	Amps (RLA), Comp. 1	25/25	25/25	12.2	12.2	9	9
	Amps (LRA), Comp. 1	164/164	164/164	100	100	78	78
	HP, Compressor 2	6	6	6	6	6	6
	Amps (RLA), Comp. 2	25/25	25/25	12.8	12.8	9.6	9.6
Amps (LRA), Comp. 2	164/164	164/164	100	100	78	78	
Compressor Motor	No.	3	3	3	3	3	3
	Volts	208/230	208/230	460	460	575	575
	Phase	1	1	1	1	1	1
	HP	1/2	1/2	1/2	1/2	1/2	1/2
	Amps (FLA, each)	2.3/2.3	2.3/2.3	1.5	1.5	1	1
	Amps (LRA, each)	5.6/5.6	5.6/5.6	3.1	3.1	2.2	2.2
Evaporator Fan	No.	1	1	1	1	1	1
	Volts	208/230	208/230	460	460	575	575
	Phase	3	3	3	3	3	3
	HP	3	5	3	5	3	5
	Amps (FLA, each)	11.5/11.5	14.9/14.9	4.6	6.6	3.5	5.3
	Amps (LRA, each)	74.5/74.5	82.6/82.6	38.1	46.3	20	39.4

ELECTRICAL DATA – RLKL- SERIES

		B240CL	B240CM	B240CN	B240DL	B240DM	B240DN	B240YL	B240YM	B240YN
Unit Information	Unit Operating Voltage Range	187-253	187-253	187-253	414-506	414-506	414-506	518-632	518-632	518-632
	Volts	208/230	208/230	208/230	460	460	460	575	575	575
	Minimum Circuit Ampacity	94/94	102/102	102/102	51	54	54	37	39	39
	Minimum Overcurrent Protection Device Size	110/110	110/110	110/110	60	60	60	40	45	45
	Maximum Overcurrent Protection Device Size	125/125	125/125	125/125	60	70	70	45	50	50
Compressor Motor	No.	2	2	2	2	2	2	2	2	2
	Volts	200/230	200/230	200/230	460	460	460	575	575	575
	Phase	3	3	3	3	3	3	3	3	3
	RPM	3450	3450	3450	3450	3450	3450	3450	3450	3450
	HP, Compressor 1	10	10	10	10	10	10	10	10	10
	Amps (RLA), Comp. 1	33.6/33.6	33.6/33.6	33.6/33.6	17.9	17.9	17.9	12.8	12.8	12.8
	Amps (LRA), Comp. 1	239/239	239/239	239/239	125	125	125	80	80	80
	HP, Compressor 2	8 1/2	8 1/2	8 1/2	8 1/2	8 1/2	8 1/2	8 1/2	8 1/2	8 1/2
	Amps (RLA), Comp. 2	30.1/30.1	30.1/30.1	30.1/30.1	16.7	16.7	16.7	12.2	12.2	12.2
Amps (LRA), Comp. 2	225/225	225/225	225/225	114	114	114	80	80	80	
Compressor Motor	No.	3	3	3	3	3	3	3	3	3
	Volts	208/230	208/230	208/230	460	460	460	575	575	575
	Phase	1	1	1	1	1	1	1	1	1
	HP	1/2	1/2	1/2	1/2	1/2	1/2	1/2	1/2	1/2
	Amps (FLA, each)	2.3/2.3	2.3/2.3	2.3/2.3	1.5	1.5	1.5	1	1	1
	Amps (LRA, each)	5.6/5.6	5.6/5.6	5.6/5.6	3.1	3.1	3.1	2.2	2.2	2.2
Evaporator Fan	No.	1	1	1	1	1	1	1	1	1
	Volts	208/230	208/230	208/230	460	460	460	575	575	575
	Phase	3	3	3	3	3	3	3	3	3
	HP	5	7 1/2	7 1/2	5	7 1/2	7 1/2	5	7 1/2	7 1/2
	Amps (FLA, each)	14.7/14.7	23.1/23.1	23.1/23.1	6.6	9.6	9.6	5.3	7.8	7.8
	Amps (LRA, each)	82.6/82.6	136/136	136/136	46.3	67	67	39.4	53.8	53.8

208/240 VOLT, THREE PHASE, 60 HZ, AUXILIARY ELECTRIC HEATER KITS CHARACTERISTICS AND APPLICATION													
Separate Power Supply for Both Unit and Heater Kit													
Model No. RLKL-	Single Power Supply for Both Unit and Heater Kit				Air Conditioner				Heater Kit				
	RXJJ-Heater Kit Nominal kW	No. of Sequence Steps	Rated Heater kW @ 208/240V	Heater kBTU/Hr @ 208/240V	Heater Amps @ 208/240V	Unit Min. Ampacity @ 208/240V	Over Current Protective Device Size Min./Max. 208V	Over Current Protective Device Size Min./Max. 240V	Min. Ckt. Ampacity 208/240V	Max. Fuse Size 208/240V	Min. Circuit Ampacity 208/240V	Over Current Protective Device Size Min./Max. 208V	Over Current Protective Device Size Min./Max. 240V
B180CL	No Heat	—	—	—	—	75/75	90/90	90/90	—	—	75/75	90/90	90/90
	CE20C	1	14.4/19.2	49.13/65.5	40/46.2	75/75	90/90	90/90	50/58	50/60	75/75	90/90	90/90
	CE40C	2	28.8/38.3	98.25/130.66	79.9/92.2	115/130	125/125	150/150	100/116	100/125	75/75	90/90	90/90
	CE60C	2	43.2/57.5	147.38/196.16	119.9/138.3	165/188	175/175	200/200	150/173	150/175	75/75	90/90	90/90
	CE75C	2	54/71.9	184.22/245.29	149.8/172.8	202/231	225/225	250/250	188/217	200/225	75/75	90/90	90/90
B240CL	No Heat	—	—	—	—	94/94	110/125	110/125	—	—	94/94	110/125	110/125
	CE20C	1	14.4/19.2	49.13/65.5	40/46.2	94/94	110/125	110/125	50/58	50/60	94/94	110/125	110/125
	CE40C	2	28.8/38.3	98.25/130.66	79.9/92.2	119/134	125/125	150/150	100/116	100/125	94/94	110/125	110/125
	CE60C	2	43.2/57.5	147.38/196.16	119.9/138.3	169/192	175/175	200/200	150/173	150/175	94/94	110/125	110/125
	CE75C	2	54/71.9	184.22/245.29	149.8/172.8	206/235	225/225	250/250	188/217	200/225	94/94	110/125	110/125
B180CM	No Heat	—	—	—	—	78/78	90/100	90/100	—	—	78/78	90/100	90/100
	CE20C	1	14.4/19.2	49.13/65.5	40/46.2	78/78	90/100	90/100	50/58	50/60	78/78	90/100	90/100
	CE40C	2	28.8/38.3	98.25/130.66	79.9/92.2	119/134	125/125	150/150	100/116	100/125	78/78	90/100	90/100
	CE60C	2	43.2/57.5	147.38/196.16	119.9/138.3	169/192	175/175	200/200	150/173	150/175	78/78	90/100	90/100
	CE75C	2	54/71.9	184.22/245.29	149.8/172.8	206/235	225/225	250/250	188/217	200/225	78/78	90/100	90/100
B240CM	No Heat	—	—	—	—	102/102	110/125	110/125	—	—	102/102	110/125	110/125
	CE20C	1	14.4/19.2	49.13/65.5	40/46.2	102/102	125/125	125/125	50/58	50/60	102/102	110/125	110/125
	CE40C	2	28.8/38.3	98.25/130.66	79.9/92.2	129/145	150/150	150/150	100/116	100/125	102/102	110/125	110/125
	CE60C	2	43.2/57.5	147.38/196.16	119.9/138.3	179/202	200/200	225/225	150/173	150/175	102/102	110/125	110/125
	CE75C	2	54/71.9	184.22/245.29	149.8/172.8	217/245	225/225	250/250	188/217	200/225	102/102	110/125	110/125
B240CN	No Heat	—	—	—	—	101/101	110/125	110/125	—	—	102/102	110/125	110/125
	CE20C	1	14.4/19.2	49.13/65.5	40/46.2	101/101	125/125	125/125	50/58	50/60	102/102	110/125	110/125
	CE40C	2	28.8/38.3	98.25/130.66	79.9/92.2	129/145	150/150	150/150	100/116	100/125	102/102	110/125	110/125
	CE60C	2	43.2/57.5	147.38/196.16	119.9/138.3	179/202	200/200	225/225	150/173	150/175	102/102	110/125	110/125
	CE75C	2	54/71.9	184.22/245.29	149.8/172.8	217/245	225/225	250/250	188/217	200/225	102/102	110/125	110/125

+ = Field installed only.

480 VOLT, THREE PHASE, 60 HZ, AUXILIARY ELECTRIC HEATER KITS CHARACTERISTICS AND APPLICATION													
Single Power Supply for Both Unit and Heater Kit							Separate Power Supply for Both Unit and Heater Kit						
Model No. RLKL-	RXJJ-Heater Kit Nominal kW	No. of Sequence Steps	Rated Heater kW @ 480V	Heater kBTU/Hr @ 480V	Heater Amps @ 480V	Unit Min. Ckt. Ampacity @ 480V	Air Conditioner		Heater Kit		Air Conditioner		
							Over Current Protective Device Size Min./Max. 480V	Over Current Protective Device Size Min./Max. 480V	Min. Ckt. Ampacity 480V	Max. Fuse Size 480V	Min. Circuit Ampacity 480V	Over Current Protective Device Size Min./Max. 480V	
180DL	No Heat	—	—	—	—	38	45/50	—	—	—	38	45/50	—
	CE20D	1	19.2	65.5	23.1	38	45/50	—	29	30	38	45/50	—
	CE40D	2	38.4	131	46.2	64	70/70	—	58	60	38	45/50	—
	CE60D	2	57.6	196.5	69.3	93	100/100	—	87	90	38	45/50	—
	CE75D	2	72	245.63	86.6	114	125/125	—	109	110	38	45/50	—
240DL	No Heat	—	—	—	—	51	60/60	—	—	—	51	60/60	—
	CE20D	1	19.2	65.5	23.1	51	60/60	—	29	30	51	60/60	—
	CE40D	2	38.4	131	46.2	67	70/70	—	58	60	51	60/60	—
	CE60D	2	57.6	196.5	69.3	95	100/100	—	87	90	51	60/60	—
	CE75D	2	72	245.63	86.6	117	125/125	—	109	110	51	60/60	—
180DM	No Heat	—	—	—	—	40	45/50	—	—	—	40	45/50	—
	CE20D	1	19.2	65.5	23.1	40	45/50	—	29	30	40	45/50	—
	CE40D	2	38.4	131	46.2	67	70/70	—	58	60	40	45/50	—
	CE60D	2	57.6	196.5	69.3	95	100/100	—	87	90	40	45/50	—
	CE75D	2	72	245.63	86.6	117	125/125	—	109	110	40	45/50	—
240DM	No Heat	—	—	—	—	54	60/70	—	—	—	54	60/70	—
	CE20D	1	19.2	65.5	23.1	54	60/70	—	29	30	54	60/70	—
	CE40D	2	38.4	131	46.2	70	70/70	—	58	60	54	60/70	—
	CE60D	2	57.6	196.5	69.3	99	100/100	—	87	90	54	60/70	—
	CE75D	2	72	245.63	86.6	121	125/125	—	109	110	54	60/70	—
240DN	No Heat	—	—	—	—	54	60/70	—	—	—	54	60/70	—
	CE20D	1	19.2	65.5	23.1	54	60/70	—	29	30	54	60/70	—
	CE40D	2	38.4	131	46.2	70	70/70	—	58	60	54	60/70	—
	CE60D	2	57.6	196.5	69.3	99	100/100	—	87	90	54	60/70	—
	CE75D	2	72	245.63	86.6	121	125/125	—	109	110	54	60/70	—

+ = Field installed only.

600 VOLT, THREE PHASE, 60 HZ, AUXILIARY ELECTRIC HEATER KITS CHARACTERISTICS AND APPLICATION															
Separate Power Supply for Both Unit and Heater Kit															
Single Power Supply for Both Unit and Heater Kit															
Model No. RLKL-	Heater Kit					Air Conditioner					Heater Kit			Air Conditioner	
	RXJJ-Heater Kit Nominal kW	No. of Sequence Steps	Rated Heater kW @ 600V	Heater kBTU/Hr @ 600V	Heater Amps @ 600V	Unit Min. Ampacity @ 600V	Over Current Protective Device Size Min./Max. 600V	Min. Ckt. Ampacity 600V	Max. Fuse Size 600V	Min. Circuit Ampacity 600V	Over Current Protective Device Size Min./Max. 600V	Min. Circuit Ampacity 600V	Max. Fuse Size 600V	Over Current Protective Device Size Min./Max. 600V	
B180YL	No Heat	—	—	—	—	28	30/35	—	—	28	30/35	—	—	—	
	CE20Y	1	19.2	65.5	18.5	28	30/35	—	24	28	30/35	25	30/35	—	
	CE40Y	2	38.4	131	37	51	60/60	—	47	28	30/35	50	30/35	—	
	CE60Y	2	57.6	196.5	55.4	74	80/80	—	70	28	30/35	70	30/35	—	
B240YL	CE75Y	2	72	245.63	69.3	92	100/100	—	87	28	30/35	90	30/35	—	
	No Heat	—	—	—	—	37	40/45	—	—	37	40/45	—	—	—	
	CE20Y	1	19.2	65.5	18.5	37	40/45	—	24	37	40/45	25	40/45	—	
	CE40Y	2	38.4	131	37	53	60/60	—	47	37	40/45	50	40/45	—	
B180YM	CE60Y	2	57.6	196.5	55.4	76	80/80	—	70	37	40/45	70	40/45	—	
	CE75Y	2	72	245.63	69.3	94	100/100	—	87	37	40/45	90	40/45	—	
	No Heat	—	—	—	—	30	35/35	—	—	30	35/35	—	—	—	
	CE20Y	1	19.2	65.5	18.5	30	35/35	—	24	30	35/35	25	35/35	—	
B240YM	CE40Y	2	38.4	131	37	53	60/60	—	47	30	35/35	50	35/35	—	
	CE60Y	2	57.6	196.5	55.4	76	80/80	—	70	30	35/35	70	35/35	—	
	CE75Y	2	72	245.63	69.3	94	100/100	—	87	30	35/35	90	35/35	—	
	No Heat	—	—	—	—	39	45/50	—	—	39	45/50	—	—	—	
B240YN	CE20Y	1	19.2	65.5	18.5	39	45/50	—	24	39	45/50	25	45/50	—	
	CE40Y	2	38.4	131	37	57	60/60	—	47	39	45/50	50	45/50	—	
	CE60Y	2	57.6	196.5	55.4	80	80/80	—	70	39	45/50	70	45/50	—	
	CE75Y	2	72	245.63	69.3	97	100/100	—	87	39	45/50	90	45/50	—	
B240Y	No Heat	—	—	—	—	39	45/50	—	—	39	45/50	—	—	—	
	CE20Y	1	19.2	65.5	18.5	39	45/50	—	24	39	45/50	25	45/50	—	
	CE40Y	2	38.4	131	37	57	60/60	—	47	39	45/50	50	45/50	—	
	CE60Y	2	57.6	196.5	55.4	80	80/80	—	70	39	45/50	70	45/50	—	
B240Y	CE75Y	2	72	245.63	69.3	97	100/100	—	87	39	45/50	90	45/50	—	
	No Heat	—	—	—	—	39	45/50	—	—	39	45/50	—	—	—	
	CE20Y	1	19.2	65.5	18.5	39	45/50	—	24	39	45/50	25	45/50	—	
	CE40Y	2	38.4	131	37	57	60/60	—	47	39	45/50	50	45/50	—	
B240Y	CE60Y	2	57.6	196.5	55.4	80	80/80	—	70	39	45/50	70	45/50	—	
	CE75Y	2	72	245.63	69.3	97	100/100	—	87	39	45/50	90	45/50	—	
	No Heat	—	—	—	—	39	45/50	—	—	39	45/50	—	—	—	
	CE20Y	1	19.2	65.5	18.5	39	45/50	—	24	39	45/50	25	45/50	—	
B240Y	CE40Y	2	38.4	131	37	57	60/60	—	47	39	45/50	50	45/50	—	
	CE60Y	2	57.6	196.5	55.4	80	80/80	—	70	39	45/50	70	45/50	—	
	CE75Y	2	72	245.63	69.3	97	100/100	—	87	39	45/50	90	45/50	—	
	No Heat	—	—	—	—	39	45/50	—	—	39	45/50	—	—	—	

+ = Field installed only.

SELF-CONTAINED AIR CONDITIONER

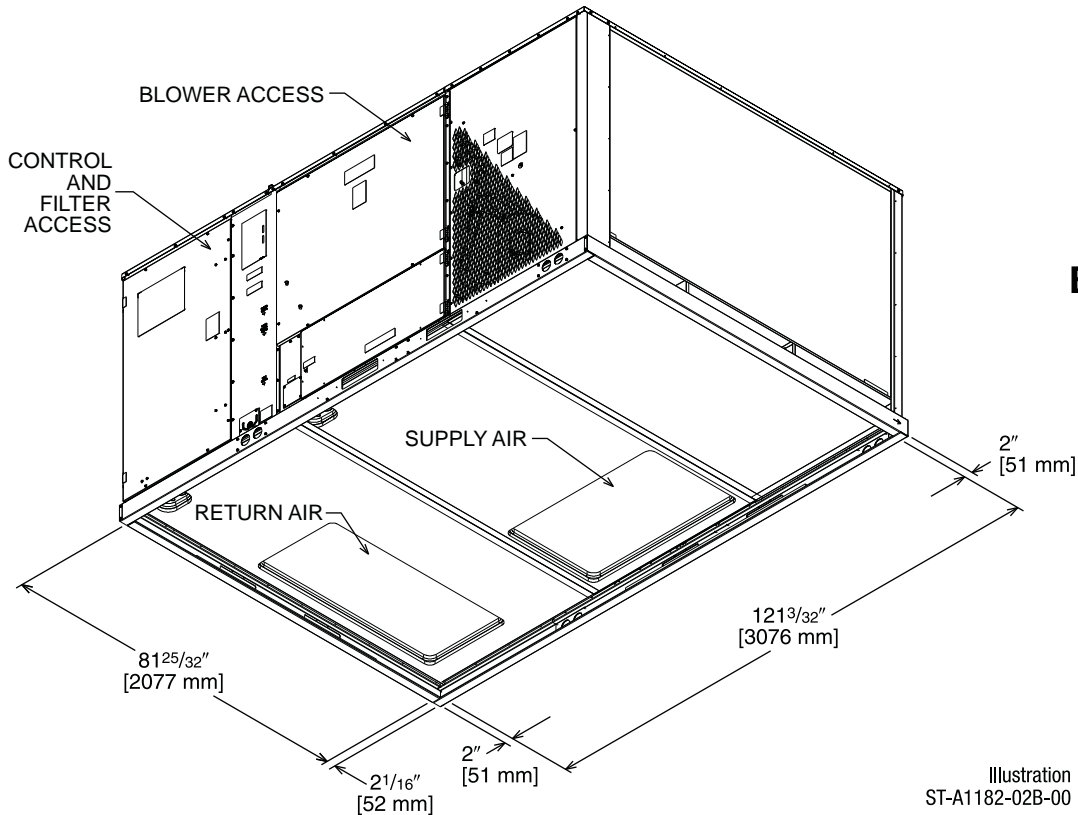
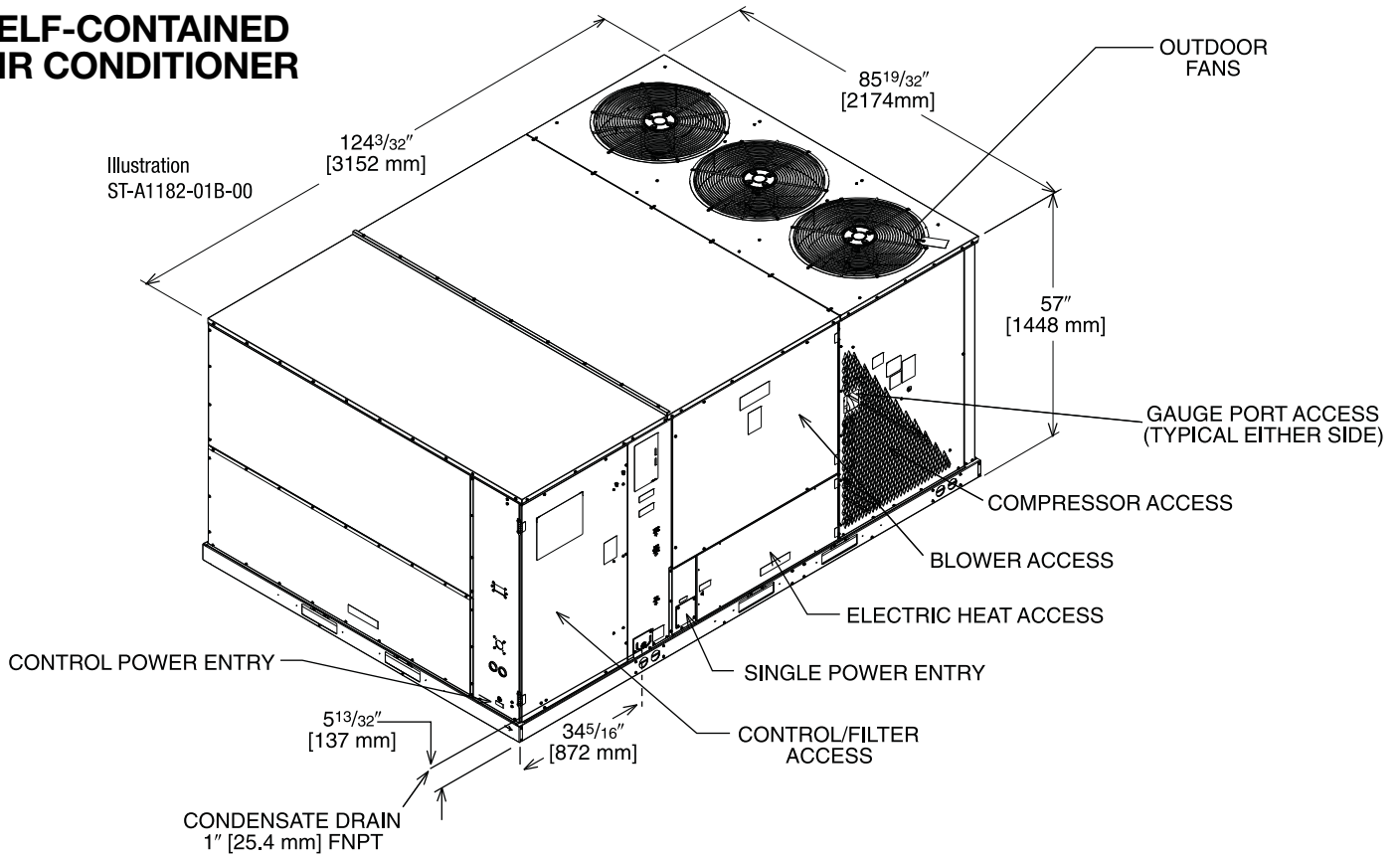

[] Designates Metric Conversions

SELF-CONTAINED AIR CONDITIONER

SUPPLY AND RETURN DIMENSIONS FOR HORIZONTAL APPLICATIONS

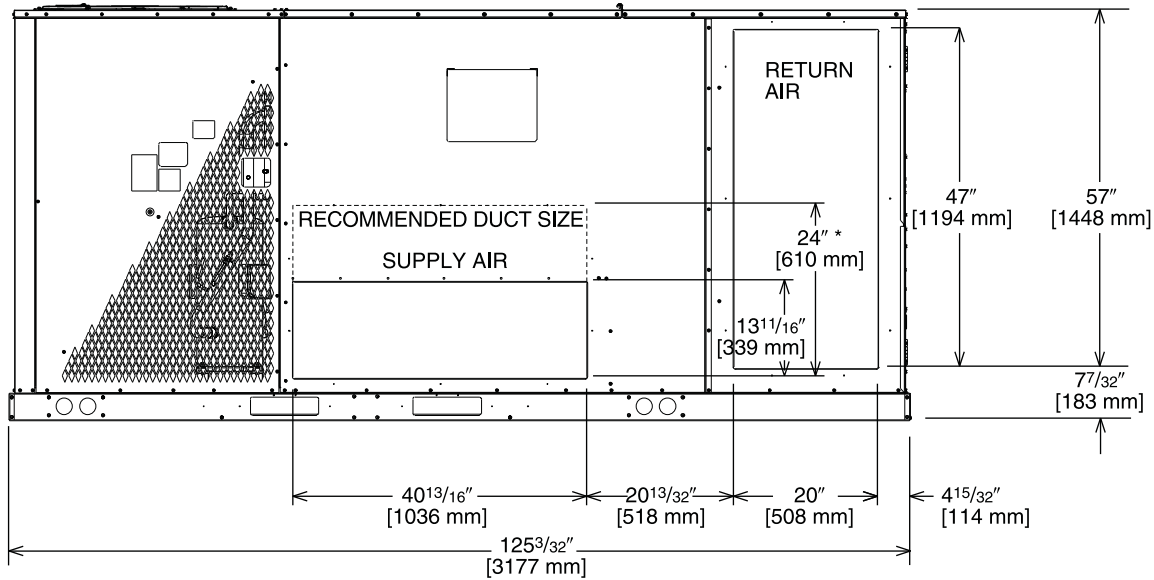

Illustration
ST-A1182-08B-00

* RECOMMENDED DUCT SIZE

DUCT SIDE VIEW (REAR)

SUPPLY AND RETURN DIMENSIONS FOR DOWNFLOW APPLICATIONS

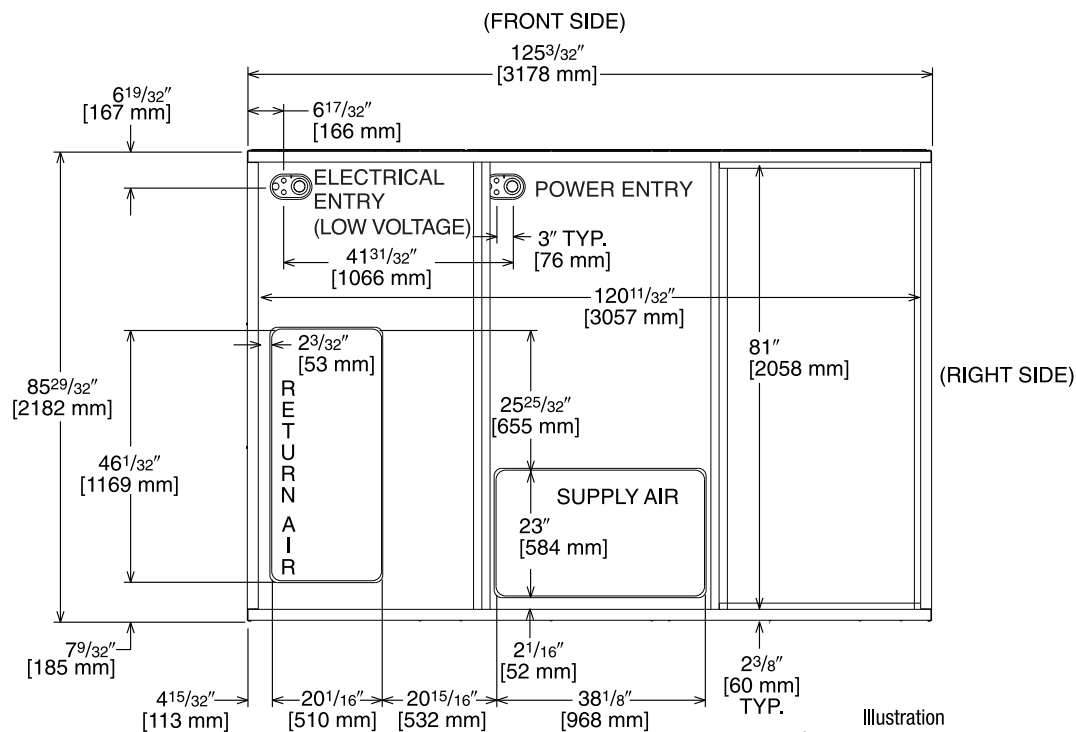
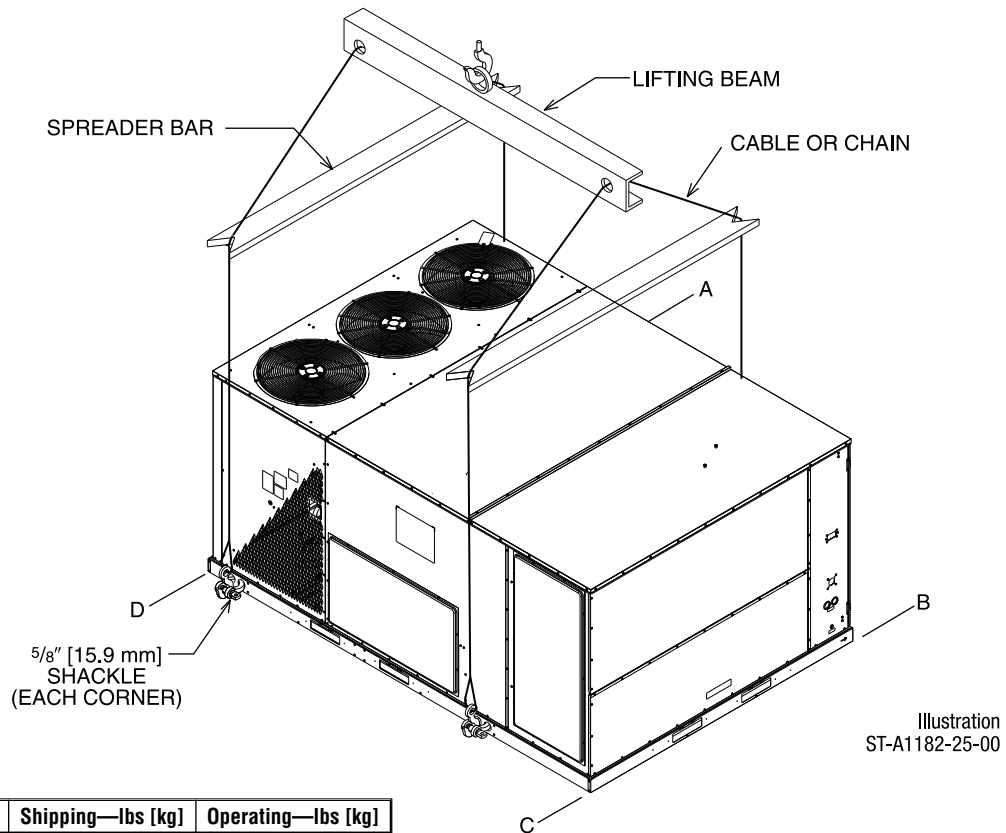
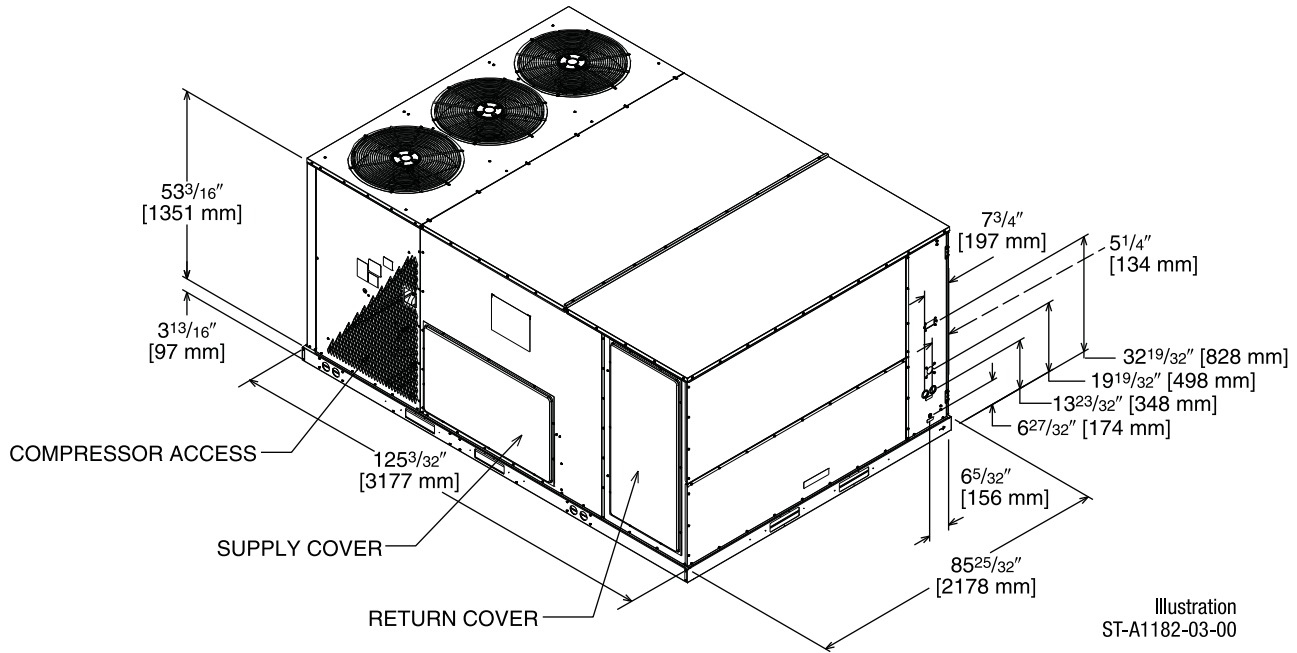

Illustration
ST-A1182-09B-00

BOTTOM VIEW

[] Designates Metric Conversions

UNIT DIMENSIONS SELF-CONTAINED AIR CONDITIONER



WEIGHTS

Accessory	Shipping—lbs [kg]	Operating—lbs [kg]
Downflow Economizer	277 [125.6]	168 [76.2]
Horizontal Economizer	333 [151.0]	301 [136.5]
Power Exhaust	119 [54.0]	59 [26.8]
Manual Fresh Air Damper*	61 [27.7]	52 [23.6]
Motor Kit for Fresh Air Damper*	42 [19.1]	35 [15.9]
Roofcurb, 14"	184 [83.5]	176 [79.8]
Hail Guard	50 [22.7]	45 [20.4]

Corner Weights by Percentage			
A	B	C	D
32%	27%	16%	24%

*Note: Corner weights measured at base of unit.

[] Designates Metric Conversions

NOTES: *Motorized Kit and Manual Fresh Air Damper must be combined for a complete Motorized Outside Air Damper Selection.

SLAB INSTALLATION

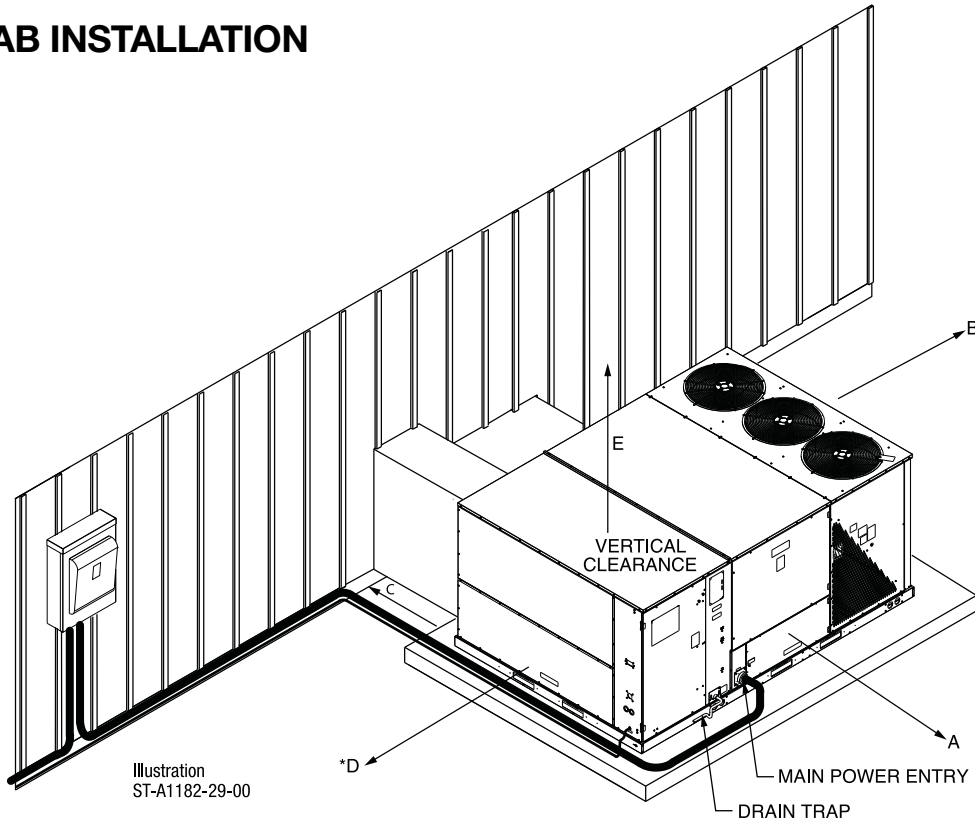

CLEARANCES

The following minimum clearances are recommended for proper unit performance and serviceability.

Recommended Clearance In. [mm]	Location
80 [2032]	A - Front
18 [457]	B - Condenser Coil
18 [457]	+C - Duct Side
18 [457]	*D - Evaporator End
60 [1524]	E - Above
*Without Economizer 18" [457 mm]. With Economizer 48" [1219 mm]. +Without Horizontal Economizer 18" [457 mm]. With Horizontal Economizer 42" [1067 mm].	

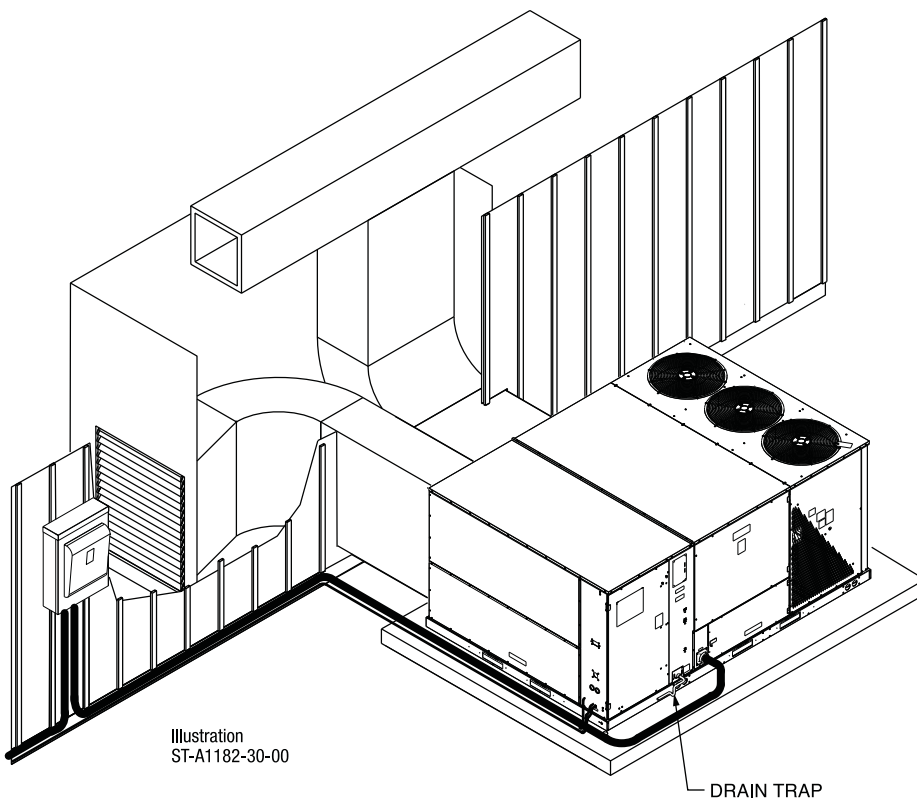

[] Designates Metric Conversions

FIELD INSTALLED ACCESSORY EQUIPMENT–SELF CONTAINED AIR CONDITIONER

Accessory Description	Model Number	Shipping Weight Lbs. [kg]	Installed Weight Lbs. [kg]	Factory Installation Available?
Thermostat or Room Sensor	See Thermostat Specification Sheet (T11-001)			No
Electric Heaters	RXJJ-CE20 (C,D,Y)	41 [18.6]	31 [14.1]	Yes
	RXJJ-CE40 (C,D,Y)	44 [20.0]	34 [15.4]	Yes
	RXJJ-CE60 (C,D,Y)	45 [20.4]	35 [15.9]	Yes
	RXJJ-CE75 (C,D,Y)	46 [20.9]	36 [16.3]	Yes
Downflow Economizer w/Single Enthalpy	AXRD-PGCM3	277 [125.6]	168 [76.2]	Yes
Downflow Economizer w/Smoke Detector	AXRD-SGCM3	280 [127.0]	171 [77.6]	Yes
Dual Enthalpy Kit	RXXR-AV02	1 [0.5]	0.5 [0.2]	No
Horizontal Economizer w/ Single Enthalpy	AXRD-RGCM3	333 [151.0]	301 [136.5]	No
Carbon Dioxide Sensor (Wall Mount)	RXXR-AR02	3 [1.4]	2 [0.9]	No
Power Exhaust (208/230V)	RXXR-BGF05C	119 [54.0]	59 [26.8]	No
Power Exhaust (460V)	RXXR-BGF05D	119 [54.0]	59 [26.8]	No
Power Exhaust (575V)	RXXR-BGF05Y	119 [54.0]	59 [26.8]	No
Manual Fresh Air Damper*	AXRF-KFA1	61 [27.7]	52 [23.6]	No
Motorized Kit for Manual Fresh Air Damper*	RXXR-AW03	42 [19.1]	35 [15.9]	No
Roofcurb, 14"	RXKG-CBH14	184 [83.5]	176 [79.8]	No
Roofcurb Adapter to RXRK-E56	RXXR-CJCE56	465 [210.9]	415 [188.2]	No
Roofcurb Adapter to RXKG-CAF14	RXXR-CJCF14	555 [251.7]	505 [229.1]	No
Concentric Diffuser (Step-Down 18" x 36")	RXRN-AD81	310 [140.6]	157 [71.2]	No
Concentric Diffuser (Step-Down 24" x 48")	RXRN-AD86	367 [166.5]	212 [96.2]	No
Concentric Diffuser (Flush, 18" x 36")	RXRN-AD80	213 [96.6]	115 [52.2]	No
Downflow Transition (Rect. To Rect. 18" x 36")	RXMC-CJ07 ¹	81 [36.7]	74 [33.6]	No
Downflow Transition (Rect. To Rect. 24" x 48")	RXMC-CK08 ²	81 [36.7]	74 [33.6]	No
Compressor Time-Delay Relay Kit	RXMD-A04	2 [0.9]	1 [0.5]	No
Low-Ambient Control Kit (1 Per Compressor)	RXRZ-C02	3 [1.4]	2 [0.9]	Yes
Freeze Stat	RXXR-AM03	1 [0.5]	0.5 [0.2]	Yes
Non-Powered Convenience Outlet	RXXR-AN01	2 [0.9]	1.5 [0.7]	Yes
Hail Guard	AXRX-AAD01K	50 [22.7]	45 [20.4]	Yes

NOTES: *Motorized Kit and Manual Fresh Air Damper must be combined for a complete Motorized Outside Air Damper Selection
 1. Used with RXRN-AD81 and RXRN-AD80 concentric diffusers 2. Used with RXRN-AD86 concentric diffusers

THERMOSTATS

[] Designates Metric Conversions



200-Series *
Programmable



300-Series *
Deluxe Programmable

400-Series *
Special Applications/
Programmable



500-Series *
Communicating/
Programmable

Brand	Descriptor (3 Characters)	Series (3 Characters)	System (2 Characters)	Type (2 Characters)
RHC	TST	213	UN	MS
RHC=Rheem	TST=Thermostat	200=Programmable 300=Deluxe Programmable 400=Special Applications/ Programmable 500=Communicating/ Programmable	GE=Gas/Electric UN=Universal (AC/HP/GE) MD=Modulating Furnace DF=Dual Fuel CM=Communicating	SS=Single-Stage MS=Multi-Stage

* Photos are representative. Actual models may vary.

For detailed thermostat match-up information, see specification sheet form number T11-001.

ECONOMIZERS—DOWNFLOW ONLY

Field Installed

- AXRD-PGCM3—Single Enthalpy (Outdoor)**
- AXRD-SGCM3—Single Enthalpy (Outdoor) w/Smoke Detector**
- RXXR-AR02—Optional Wall-Mounted CO₂ Sensor**
- RXXR-AV02—Dual Enthalpy Upgrade Kit**

- Features **Honeywell** Controls
- Available Factory Installed or Field Accessory
- Gear Driven Direct Drive Actuator
- Fully Modulating (0-100%)
- Low Leakage Dampers
- Slip-In Design for Easy Installation
- Plug-In Polarized 12-pin Electrical Connections
- Pre-Configured—No Field Adjustments Necessary
- Standard Barometric Relief Damper
- Single Enthalpy with Dual Enthalpy Upgrade Kit Available
- CO₂ Input Sensor Available
- Field Assembled Hood Ships with Economizer
- Economizer Ships Complete for Downflow Duct Application.
- Optional Remote Minimum Position Potentiometer (Honeywell #S963B1128) is Available from Prostock.
- Field Installed Power Exhaust Available

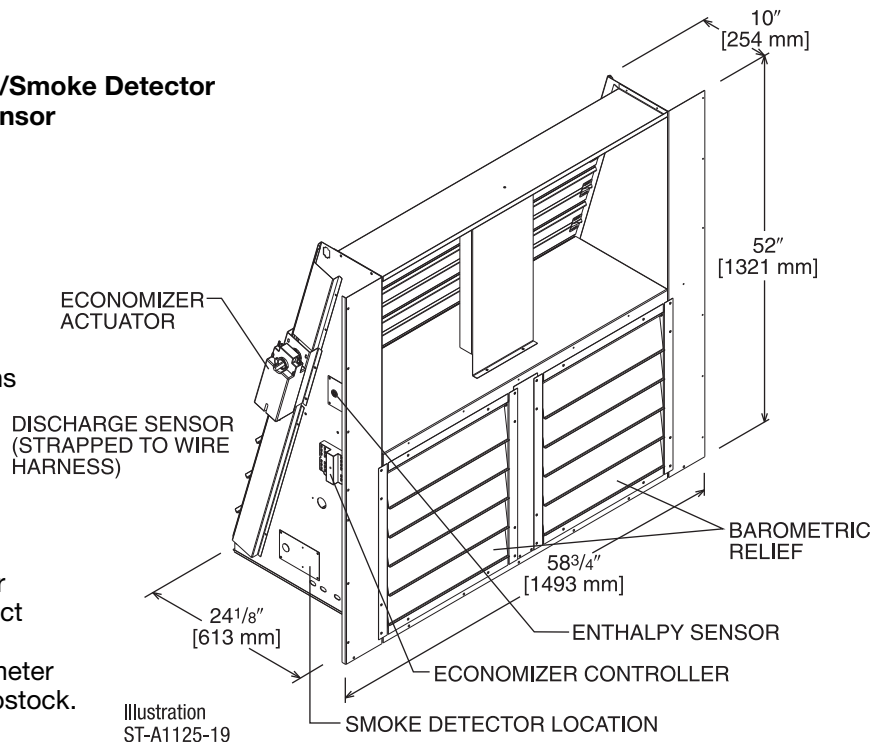

TOLERANCE ±.125

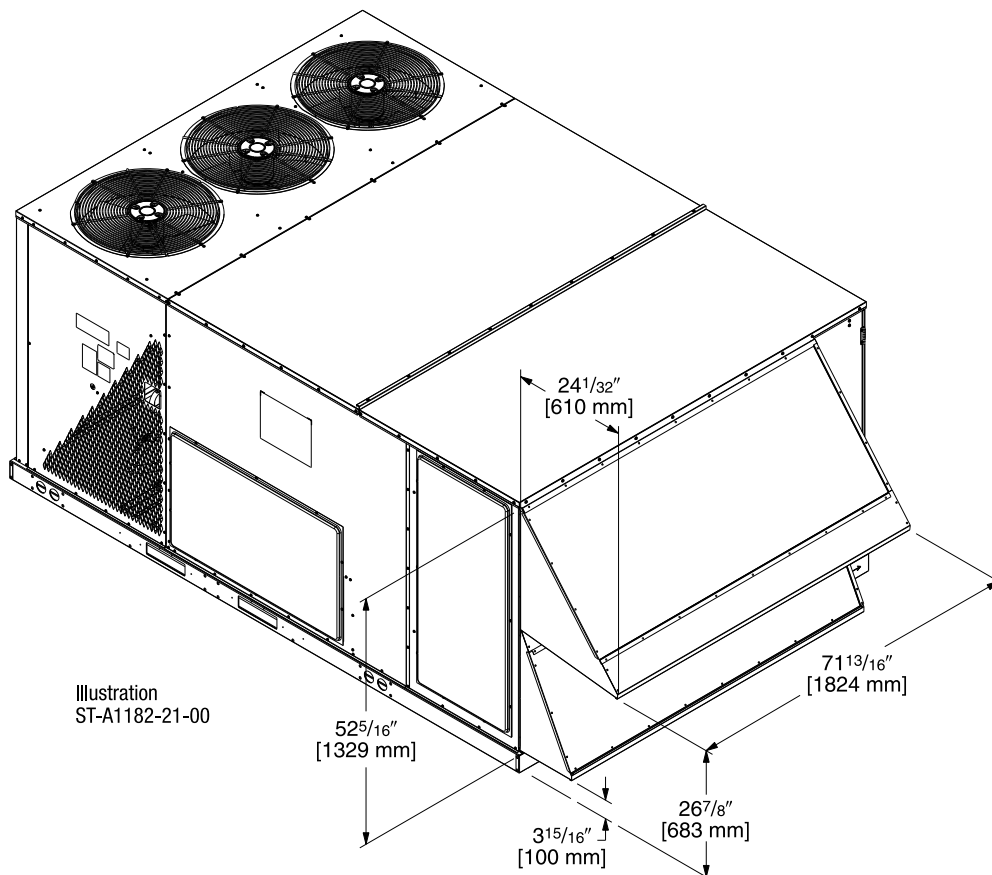

[] Designates Metric Conversions

ECONOMIZER FOR HORIZONTAL DUCT INSTALLATION

Field Installed Only

- AXRD-RGCM3—Single Enthalpy (Outdoor)**
- RXXR-AV02—Dual Enthalpy Upgrade Kit**
- RXXR-AR02—Optional Wall-Mounted CO₂ Sensor**

- Features **Honeywell** Controls
- Available as a Field Installed Accessory Only
- Gear Driven Direct Drive Actuator
- Fully Modulating (0-100%)
- Low Leakage Dampers
- Slip-In Design for Easy Installation
- Plug-In Polarized 12-pin Electrical Connections
- Pre-Configured—No Field Adjustments Necessary
- Standard Barometric Relief Damper
- Single Enthalpy with Dual Enthalpy Upgrade Kit Available
- CO₂ Input Sensor Available
- Field Assembled Hood Ships with Economizer
- Economizer Ships Complete for Horizontal Duct Application
- Optional Remote Minimum Position Potentiometer (Honeywell #S963B1128) is Available from Prostock
- Field Installed Power Exhaust Available

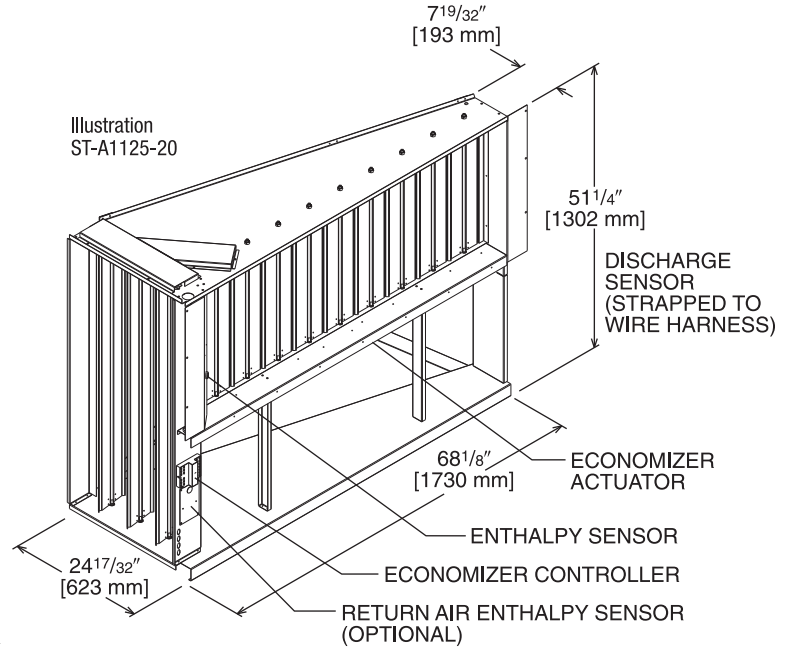

TOLERANCE $\pm .125$

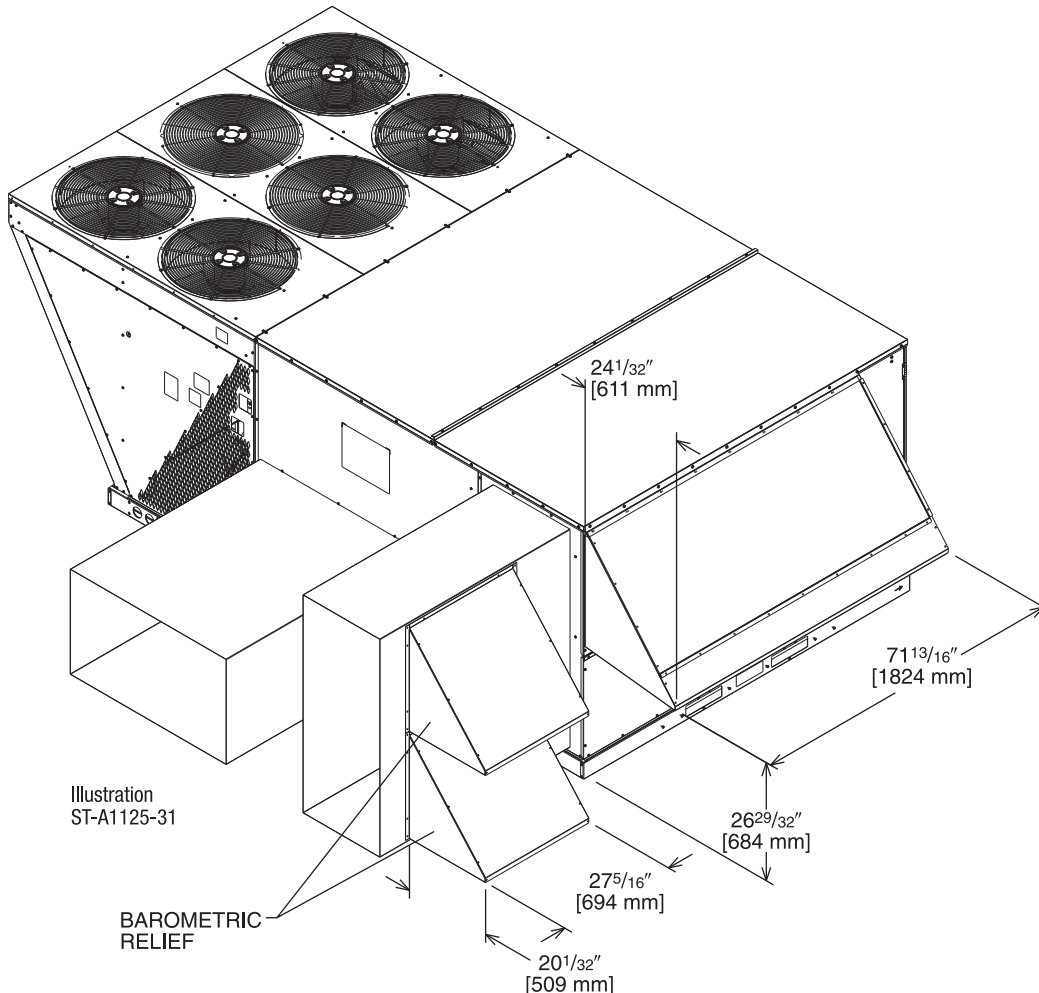

[] Designates Metric Conversions

INTEGRAL POWER EXHAUST KIT FOR RXRD-PGCM3 OR SGCM3 ECONOMIZERS

RXRX-BGF05 (C, D, or Y*)

*Voltage Code

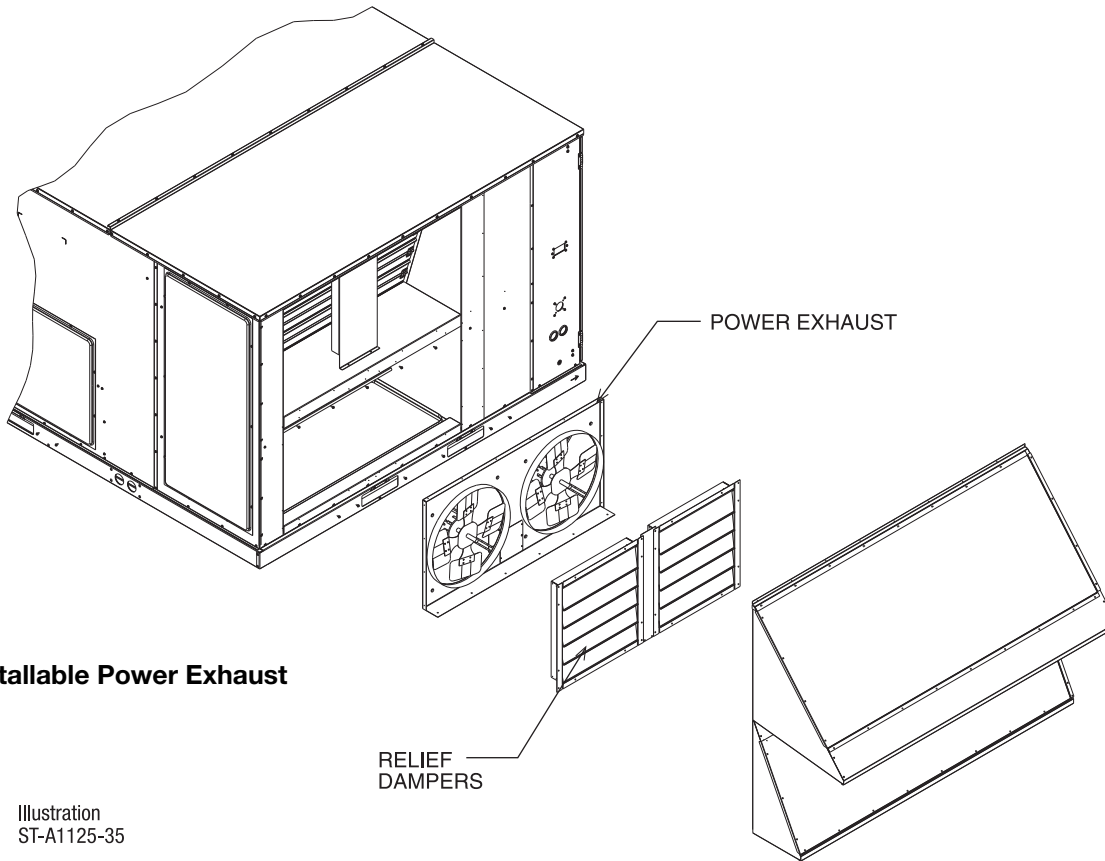

Field Installable Power Exhaust

Illustration
ST-A1125-35

Model No.	No. of Fans	Volts	Phase	HP (ea.)	Low Speed		High Speed ^①		FLA (ea.)	LRA (ea.)
					CFM [L/s] ^②	RPM	CFM [L/s] ^②	RPM		
RXRX-BGF05C	2	208-230	1	0.75	4100 [1935]	850	5200 [2454]	1050	5	4.97
RXRX-BGF05D	2	460	1	0.75	4100 [1935]	850	5200 [2454]	1050	2.2	3.4
RXRX-BGF05Y	2	575	1	0.75	4100 [1935]	850	5200 [2454]	1050	1.5	2.84

NOTES: ^① Power exhaust is factory set on high speed motor tap.

^② CFM is per fan at 0" w.c. external static pressure.

[] Designates Metric Conversions

FRESH AIR DAMPER

MOTORIZED DAMPER KIT
RXRX-AW03
(Motor Kit for RXRF-KFA1)

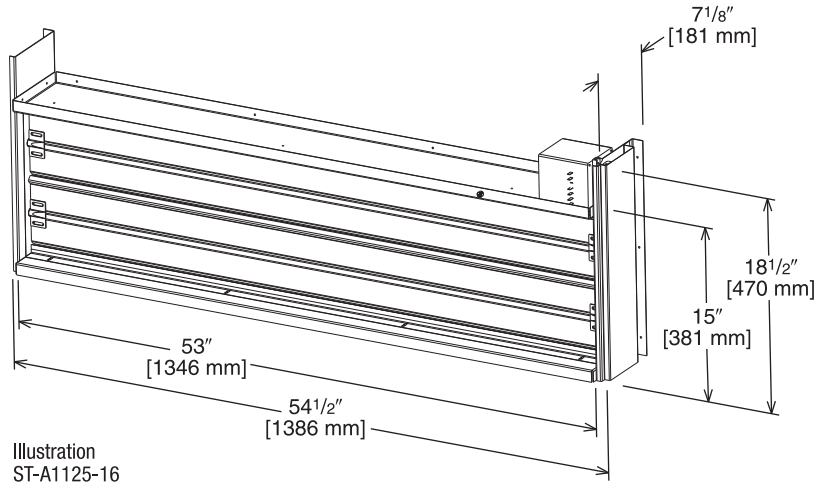

AXRF-KFA1 (Manual)
RXRX-AW03 (Motorized damper kit for manual fresh air damper)

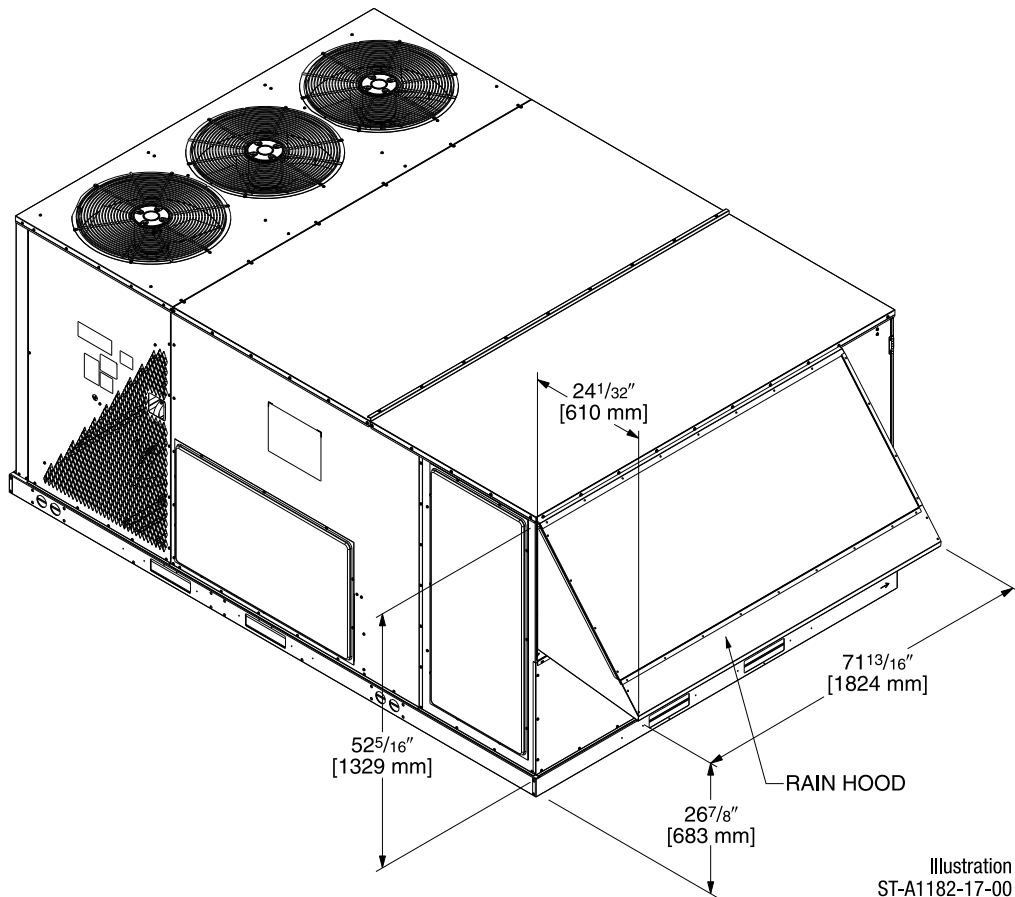

[] Designates Metric Conversions

ROOFCURBS (Full Perimeter)

- Rheem's roofcurb design can be utilized on 15 & 20 [52.8 & 70.3 kW] models.
- One available height (14" [356 mm]).
- Quick assembly corners for simple and fast assembly.
- 1" [25.4 mm] x 4" [102 mm] Nailers provided.
- Insulating panels not required because of insulated outdoor base pan.
- Sealing gasket (28" [711 mm]) provided with Roofcurb.
- Packaged for easy field assembly.

TYPICAL INSTALLATION

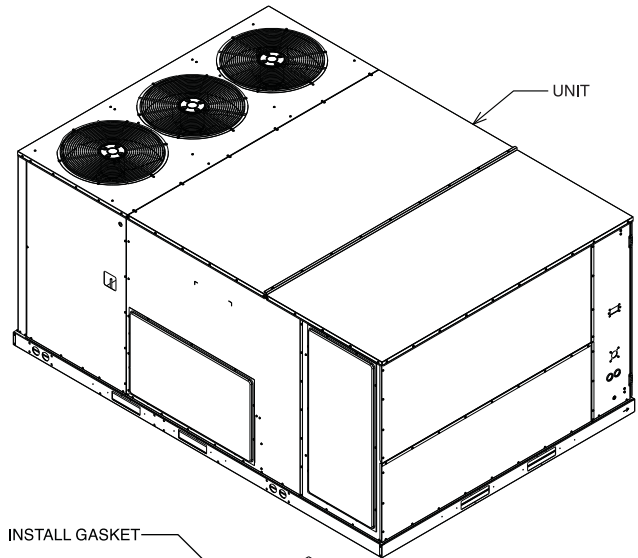

ROOFCURB ASSEMBLY

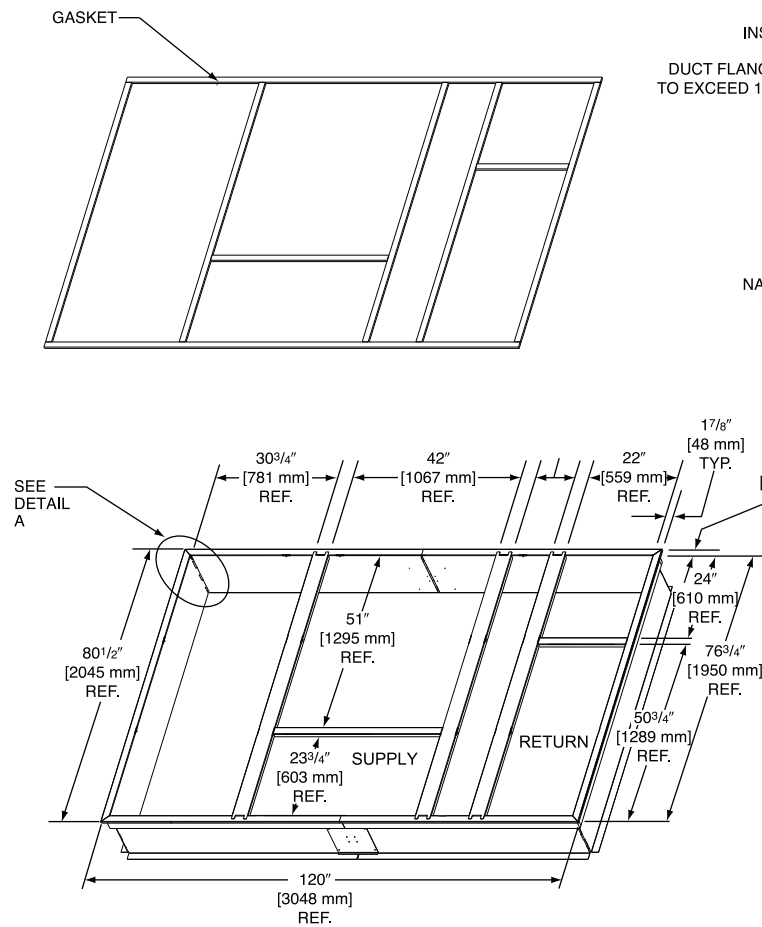

Illustration
ST-A1125-14

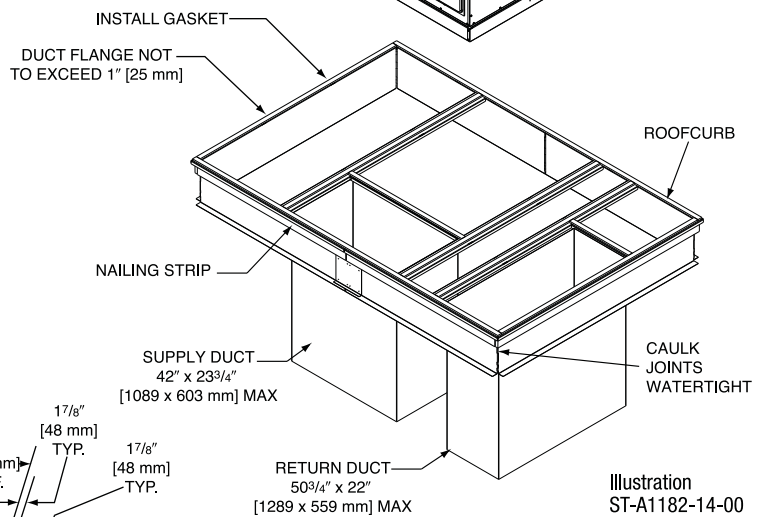
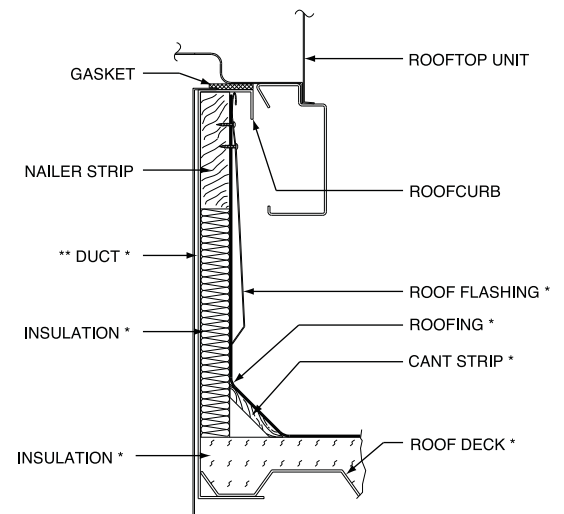
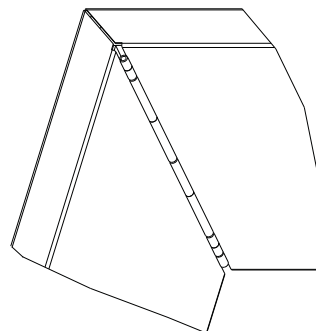

Illustration
ST-A1182-14-00



* BY CONTRACTOR

** FOR INSTALLATION OF DUCT AS SHOWN, USE RECOMMENDED DUCT SIZES FROM ROOFCURB INSTALLATION INSTRUCTIONS. FOR DUCT FLANGE ATTACHMENT TO UNIT, SEE UNIT INSTALLATION INSTRUCTIONS FOR RECOMMENDED DUCT SIZES.



DETAIL A

[] Designates Metric Conversions

ROOFCURB ADAPTERS

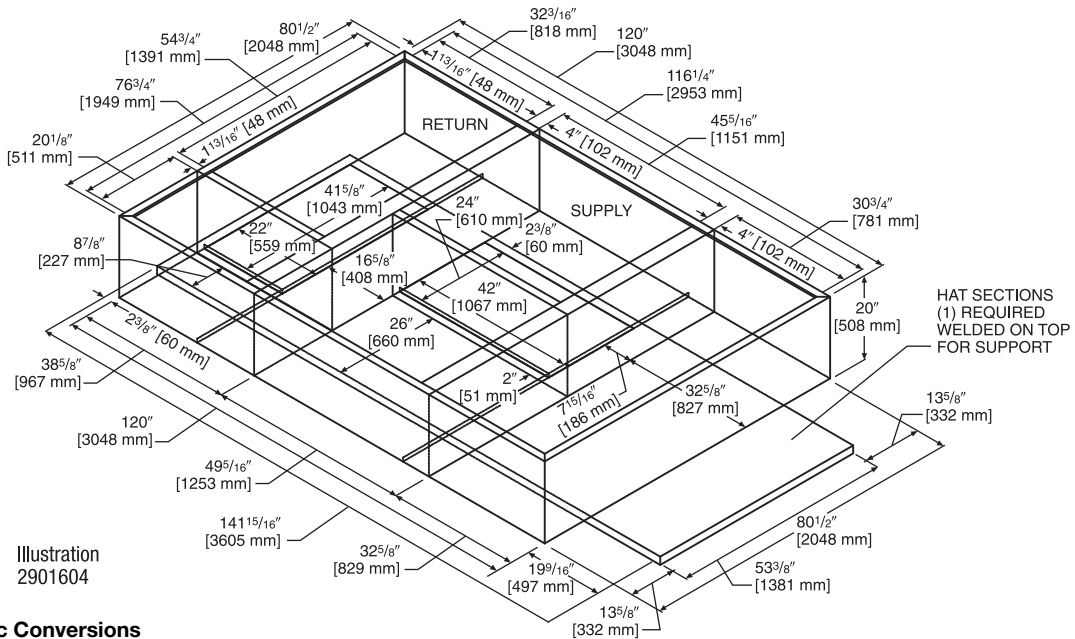
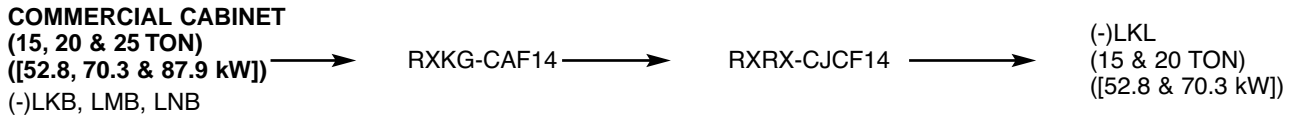
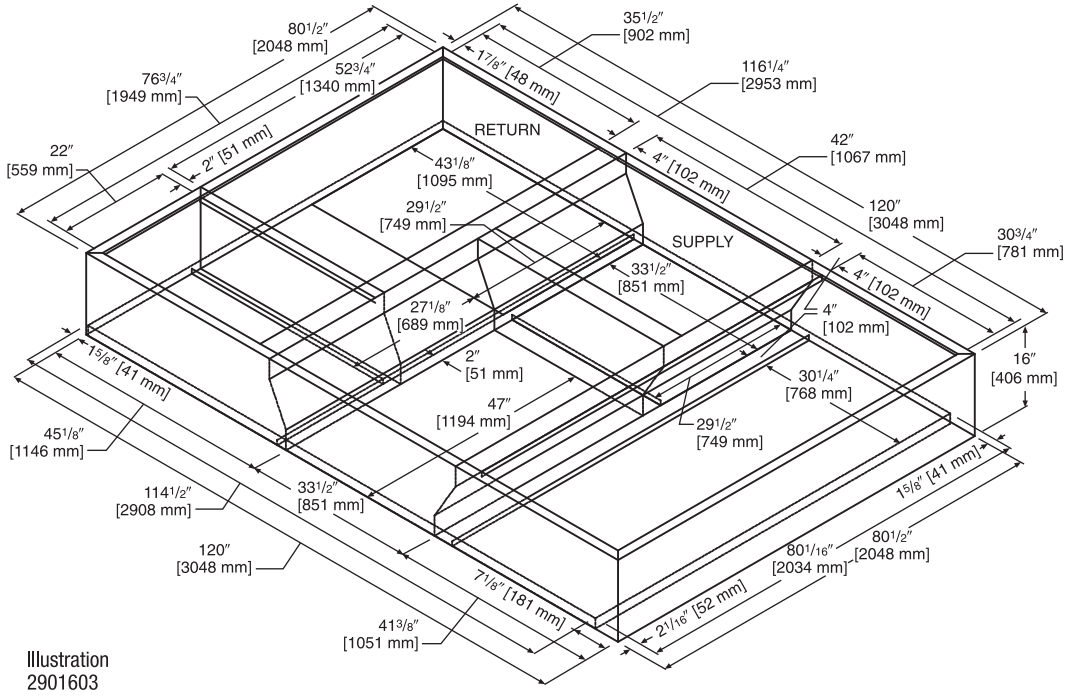
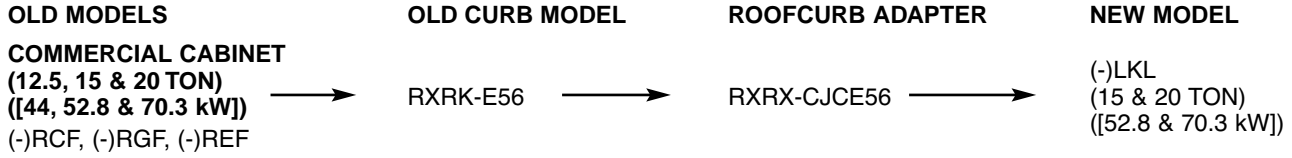

[] Designates Metric Conversions

CONCENTRIC DIFFUSER APPLICATION

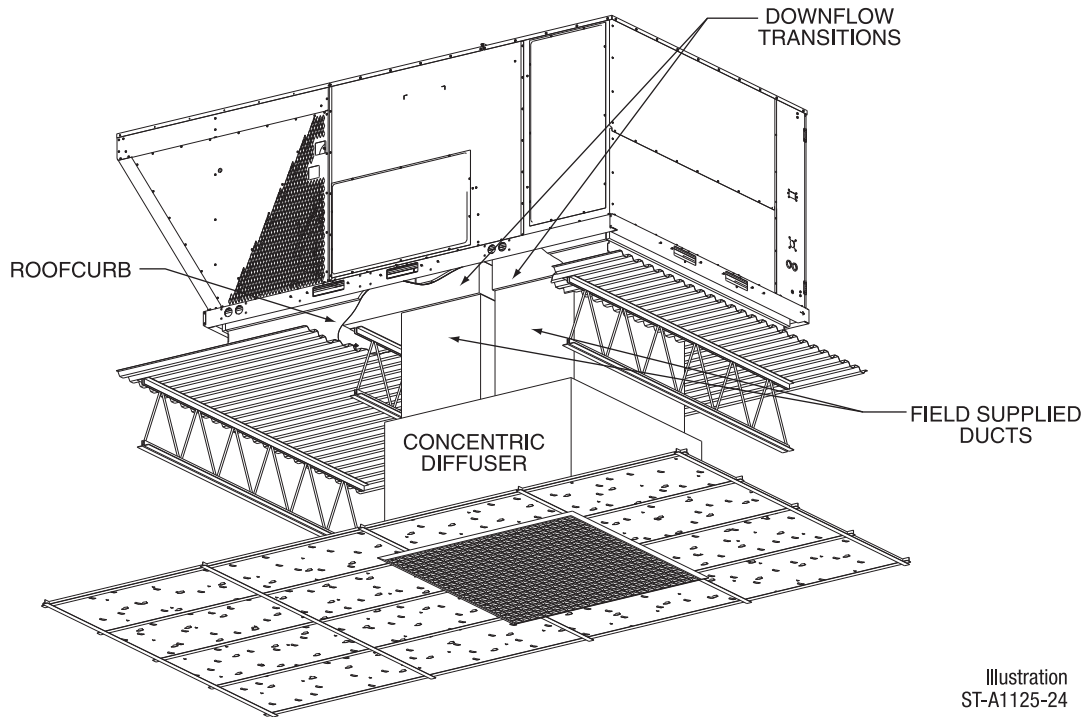

Illustration
ST-A1125-24

DOWNFLOW TRANSITION DRAWINGS

RXMC-CJ07 (15 Ton) [52.8 kW]

- Used with RXRN-AD80 and RXRN-AD81 Concentric Diffusers.

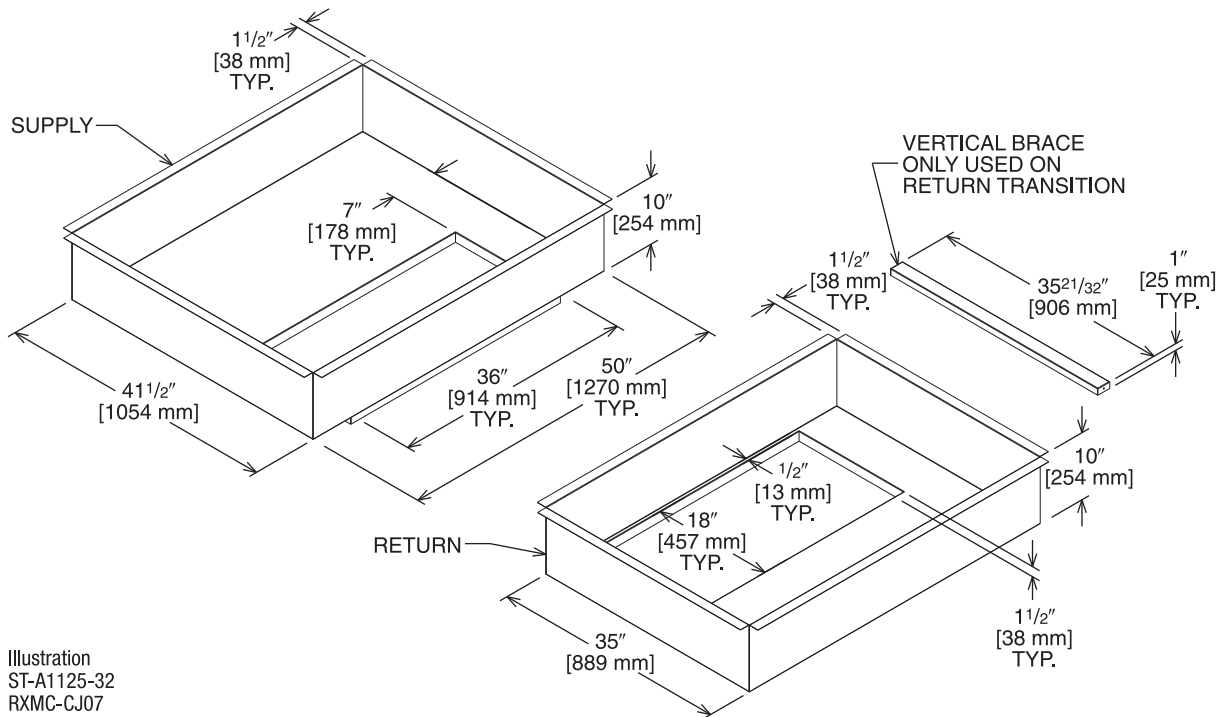

Illustration
ST-A1125-32
RXMC-CJ07

[] Designates Metric Conversions

DOWNFLOW TRANSITION DRAWINGS (Cont.)

RXMC-CK08 (20 Ton) [70.3 kW]

- Used with RXRN-AD86 Concentric Diffusers.

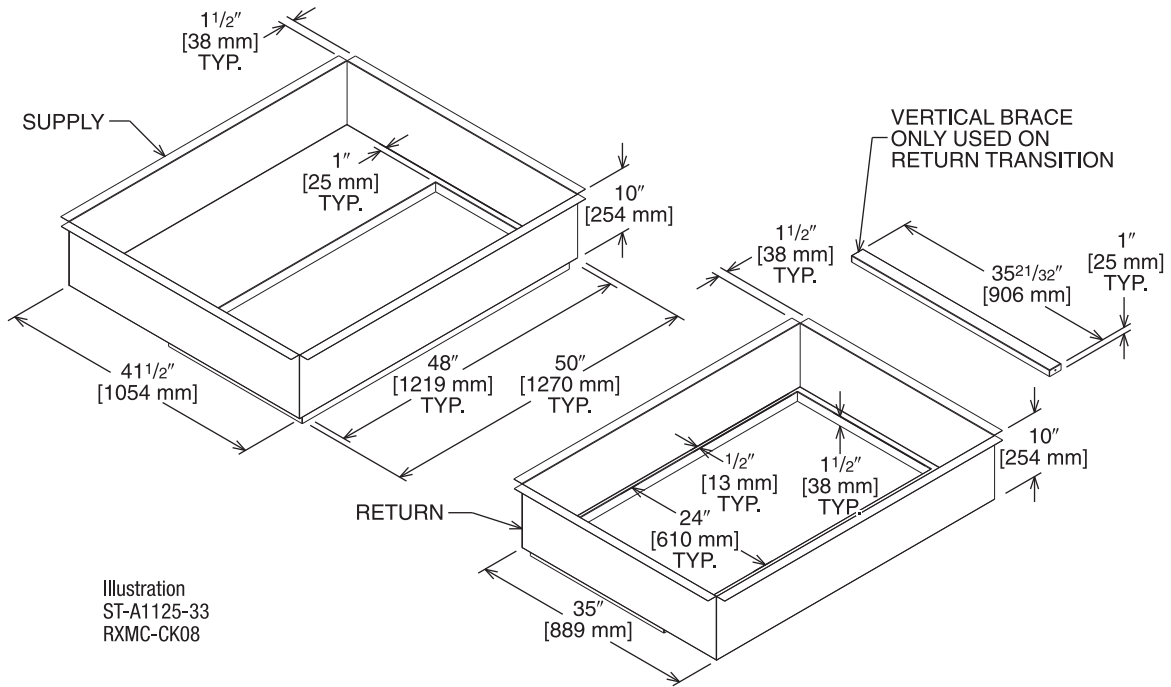

[] Designates Metric Conversions

CONCENTRIC DIFFUSER 15 TON [52.8 kW] FLUSH

- All aluminum diffuser with aluminum return air eggcrate.
- Built-in anti-sweat gasket.
- Molded fiberglass supports.
- Built-in hanging supports.
- Diffuser box constructed of sheetmetal insulated with 1" [25.4 mm] 1.5 lbs. [.7 kg] duct liner.

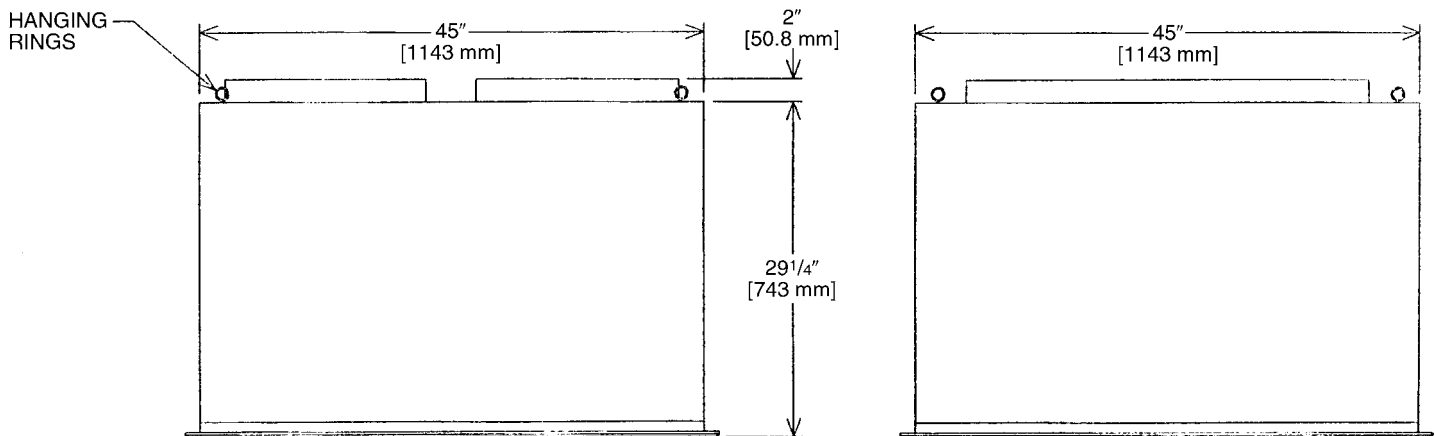
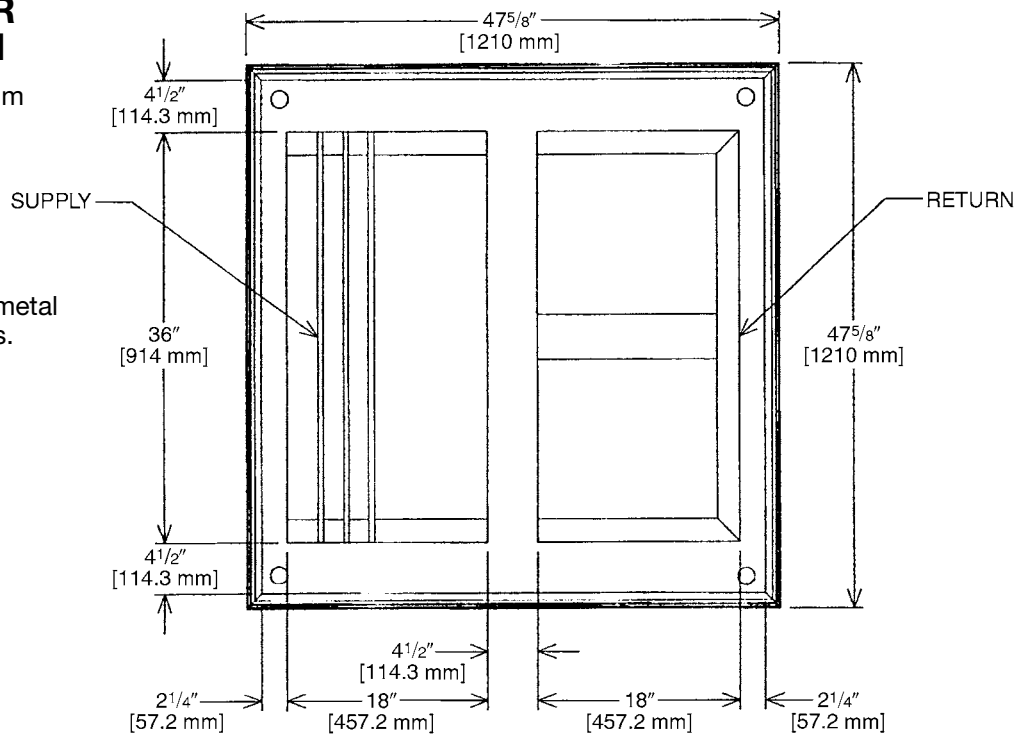

CONCENTRIC DIFFUSER SPECIFICATIONS

PART NUMBER	CFM [L/s]	STATIC PRESSURE	THROW FEET	NECK VELOCITY	JET VELOCITY
RXRN-AD80	5600 [2643]	0.36	28-37	1000	2082
	5800 [2737]	0.39	29-38	1036	2156
	6000 [2832]	0.42	40-50	1071	2230
	6200 [2926]	0.46	42-51	1107	2308
	6400 [3020]	0.50	43-52	1143	2379
	6600 [3115]	0.54	45-56	1179	2454

[] Designates Metric Conversions

CONCENTRIC DIFFUSER 15 TON [52.8 kW] STEP DOWN

- All aluminum diffuser with aluminum return air eggcrate.
- Built-in anti-sweat gasket.
- Molded fiberglass supports.
- Built-in hanging supports.
- Diffuser box constructed of sheetmetal insulated with 1" [25.4 mm] 1.5 lbs. [.7 kg] duct liner.
- Double deflection diffuser with the blades secured by spring steel.

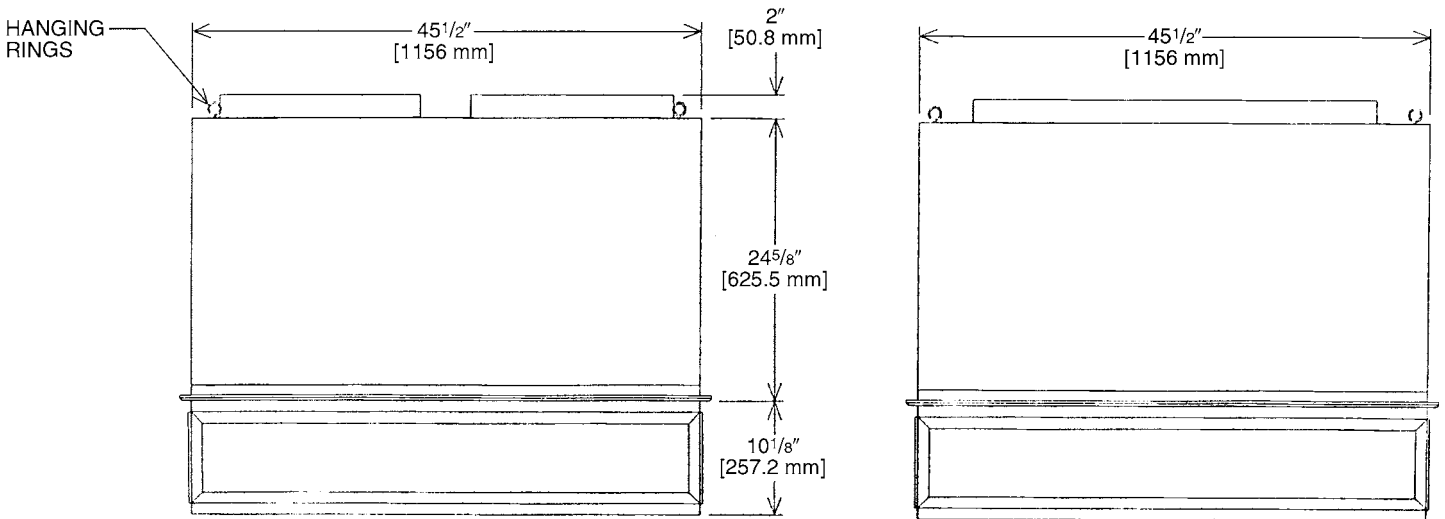
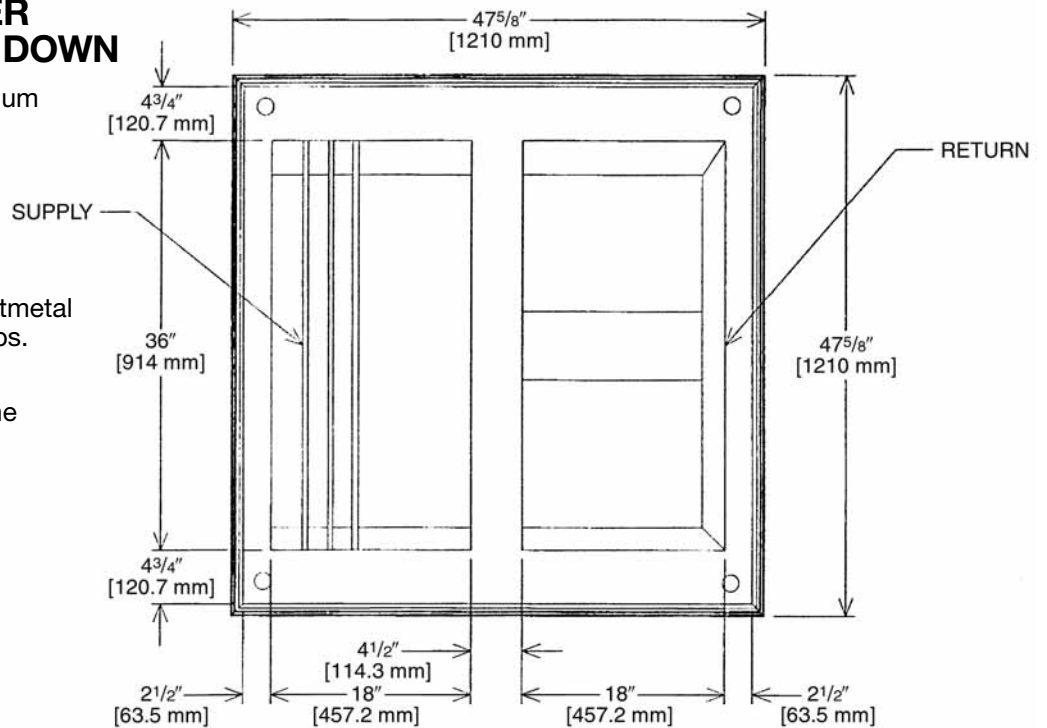

CONCENTRIC DIFFUSER SPECIFICATIONS

PART NUMBER	CFM [L/s]	STATIC PRESSURE	THROW FEET	NECK VELOCITY	JET VELOCITY
RXRN-AD81	5600 [2643]	0.36	39-49	920	920
	5800 [2737]	0.39	42-51	954	954
	6000 [2832]	0.42	44-54	1022	1022
	6200 [2926]	0.46	45-55	1056	1056
	6400 [3020]	0.50	46-55	1090	1090
	6600 [3115]	0.54	47-56	1124	1124

[] Designates Metric Conversions

CONCENTRIC DIFFUSER RXRN-AD86 SERIES 20 TON [70.3 kW] STEP DOWN

- All aluminum diffuser with aluminum return air eggcrate.
- Built-in anti-sweat gasket.
- Molded fiberglass supports.
- Built-in hanging supports.
- Diffuser box constructed of sheetmetal insulated with 1" [25.4 mm] 1.5 lbs. [.7 kg] duct liner.
- Double deflection diffuser with the blades secured by spring steel.

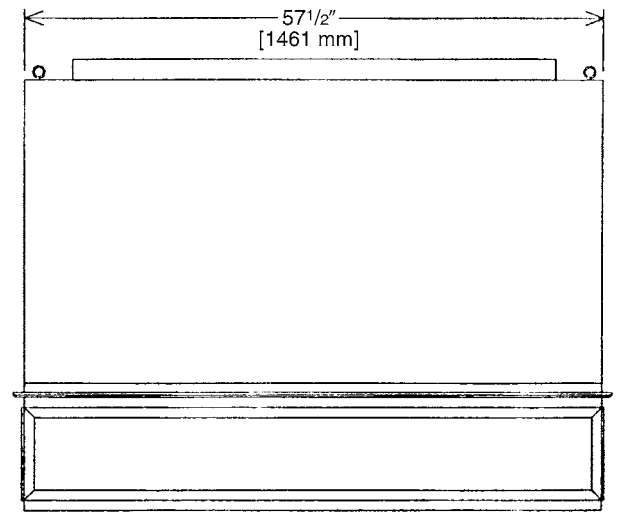
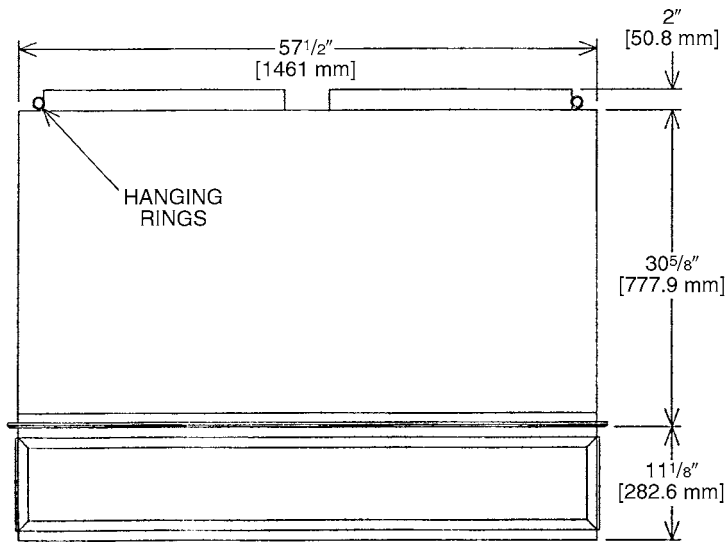
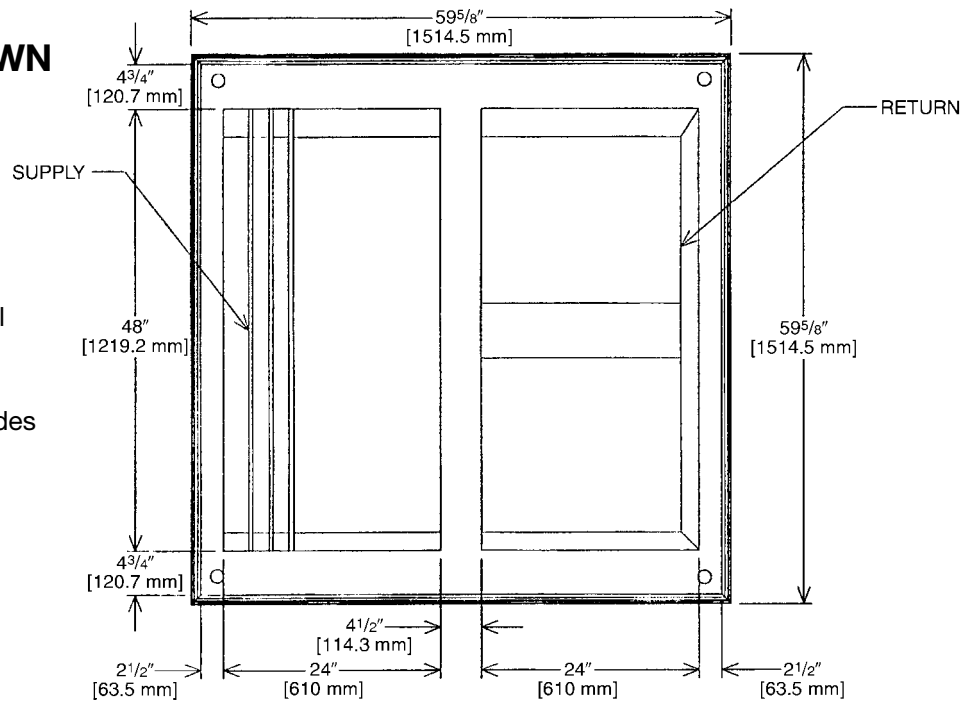

CONCENTRIC DIFFUSER SPECIFICATIONS

PART NUMBER	CFM [L/s]	STATIC PRESSURE	THROW FEET	NECK VELOCITY	JET VELOCITY
RXRN-AD86	7200 [3398]	0.39	33-38	827	827
	7400 [3492]	0.41	35-40	850	850
	7600 [3587]	0.43	36-41	873	873
	7800 [3681]	0.47	38-43	896	896
	8000 [3776]	0.50	39-44	918	918
	8200 [3870]	0.53	41-46	941	941
	8400 [3964]	0.56	43-49	964	964
	8600 [4059]	0.59	44-50	987	987
8800 [4153]	0.63	47-55	1010	1010	

[] Designates Metric Conversions

Guide Specifications RLKL-B180 thru B240

Note about this specification: Please feel free to copy this specification directly into your building spec. This specification is written to comply with the 2004 version of the “master format” as published by the Construction Specification Institute www.csinet.org.

ELECTRIC HEAT PACKAGED ROOFTOP

HVAC Guide Specifications

Size Range: 15-20 Nominal Tons

Section	Description
---------	-------------

23 06 80	Schedules for Decentralized HVAC Equipment
-----------------	---

23 06 80.13	Decentralized Unitary HVAC Equipment Schedule
--------------------	--

23 06 80.13.A.	Rooftop unit schedule
----------------	-----------------------

1. Schedule is per the project specification requirements.

23 07 16	HVAC Equipment Insulation
-----------------	----------------------------------

23 07 16.13	Decentralized, Rooftop Units:
--------------------	--------------------------------------

1. Interior cabinet surfaces shall be insulated with a minimum 3/4-in. thick, minimum 1-1/2 lb density, flexible fiberglass insulation bonded with a phenolic binder, with aluminum foil facing on the air side.
2. Insulation and adhesive shall meet NFPA 90A requirements for flame spread and smoke generation.

23 09 13	Instrumentation and Control Devices for HVAC
-----------------	---

23 09 13.23	Sensors and Transmitters:
--------------------	----------------------------------

23 09 13.23.A.	Thermostats
----------------	-------------

1. Thermostat must
 - a. energize both “W” and “G” when calling for heat.
 - b. have capability to energize 2 different stages of cooling, and 2 different stages of heating.
 - c. must include capability for occupancy scheduling.

23 09 33	Electric and Electronic Control System for HVAC
-----------------	--

23 09 33.13	Decentralized, Rooftop Units:
--------------------	--------------------------------------

23 09 33.13.A.	General:
----------------	----------

1. Shall be complete with self-contained low-voltage control circuit protected by a resettable circuit breaker on the 24-v transformer side.
2. Shall utilize color-coded wiring.
3. Unit shall include a minimum of one 9-pin screw terminal connection board for connection of control wiring.

23 09 33.23.B.	Safeties:
----------------	-----------

1. Compressor over-temperature, over current.
2. Low-pressure switch.
3. High-pressure switch.
4. Automatic reset, motor thermal overload protector.

23 09 93	Sequence of Operations for HVAC Controls
-----------------	---

23 09 93.13	Decentralized, Rooftop Units:
--------------------	--------------------------------------

23 09 93.13	INSERT SEQUENCE OF OPERATION
-------------	------------------------------

23 40 13	Panel Air Filters
-----------------	--------------------------

23 40 13.13	Decentralized, Rooftop Units:
--------------------	--------------------------------------

23 40 13.13.A.	Standard filter section shall
----------------	-------------------------------

1. Shall consist of factory-installed, low velocity, throwaway 2-in. thick fiberglass filters of commercially available sizes.
2. Unit shall use only one filter size. Multiple sizes are not acceptable.
3. Filter face velocity shall not exceed 365 fpm at nominal airflows.
4. Filters shall be accessible through an access panel as described in the unit cabinet section of the specification (23 81 19.13.H).

23 81 19	Self-Contained Air Conditioners
-----------------	--

23 81 19.13	Small-Capacity Self-Contained Air Conditioners
--------------------	---

23 81 19.13.A.	General
----------------	---------

1. Outdoor, rooftop mounted, electrically controlled, heating and cooling unit utilizing a(n) hermetic scroll compressor(s) for cooling duty and electric resistance heat for heating duty.

2. Factory assembled, single-piece heating and cooling rooftop unit. Contained within the unit enclosure shall be all factory wiring, piping, controls, and special features required prior to field start-up.
3. Unit shall use environmentally safe, R410A refrigerant.
4. Unit shall be installed in accordance with the manufacturer's instructions.
5. Unit must be selected and installed in compliance with local, state, and federal codes.

23 81 19.13.B. Quality Assurance

1. Unit meets ASHRAE 90.1-2004 minimum efficiency requirements.
2. 3 phase units are Energy Star qualified.
3. Unit shall be rated in accordance with AHRI Standards 210 and 360.
4. Unit shall be designed to conform to ASHRAE 15, 2001.
5. Unit shall be UL-tested and certified in accordance with ANSI Z21.47 Standards and UL-listed and certified under Canadian standards as a total package for safety requirements.
6. Insulation and adhesive shall meet NFPA 90A requirements for flame spread and smoke generation.
7. Unit casing shall be capable of withstanding 500-hour salt spray exposure per ASTM B117 (scribed specimen).
8. Unit casing shall be capable of withstanding Federal Test Method Standard No. 141 (Method 6061) 5000-hour salt spray.
9. Unit shall be designed in accordance with ISO 9001:2000, and shall be manufactured in a facility registered by ISO 9001:2000.
10. Roof curb shall be designed to conform to NRCA Standards.
11. Unit shall be subjected to a completely automated run test on the assembly line. The data for each unit will be stored at the factory, and must be available upon request.
12. Unit shall be designed in accordance with UL Standard 1995, including tested to withstand rain.
13. Unit shall be constructed to prevent intrusion of snow and tested to prevent snow intrusion into the control box up to 40 mph.

23 81 19.13.C. Delivery, Storage, and Handling

1. Unit shall be stored and handled per manufacturer's recommendations.
2. Lifted by crane requires either shipping top panel or spreader bars.
3. Unit shall only be stored or positioned in the upright position.

23 81 19.13.E. Project Conditions

1. As specified in the contract.

23 81 19.13.F. Operating Characteristics

1. Unit shall be capable of starting and running at 115°F (46°C) ambient outdoor temperature, meeting maximum load criteria of AHRI Standard 210/240 or 360 at $\pm 10\%$ voltage.
2. Compressor with standard controls shall be capable of operation down to 40°F (4°C), ambient outdoor temperatures. Accessory low ambient kit is necessary if mechanically cooling at ambient temperatures below 40°F (4°C).
3. Unit shall discharge supply air vertically or horizontally as shown on contract drawings.
4. Unit shall be factory configured for vertical supply & return configurations.
5. Unit shall be field convertible from vertical to horizontal configuration.

23 81 19.13.G. Electrical Requirements

1. Main power supply voltage, phase, and frequency must match those required by the manufacturer.

23 81 19.13.H. Unit Cabinet

1. Unit cabinet shall be constructed of galvanized steel, and shall be bonderized and coated with a baked enamel finish on all externally exposed surfaces.
2. Unit cabinet exterior paint shall be: film thickness, (dry) 0.003 inches minimum, gloss (per ASTM D523, 60°F / 16°C): 60, Hardness: H-2H Pencil hardness.
3. Evaporator fan compartment interior cabinet insulation shall conform to AHRI Standards 210 or 360 minimum exterior sweat criteria. Interior surfaces shall be insulated with a minimum 3/4-in. thick, 1 lb. density, flexible fiberglass insulation, aluminum foil-faced coated on the air side.
4. Base of unit shall have locations for thru-the-base gas and electrical connections (factory installed or field installed), standard.
5. Base Rail
 - a. Unit shall have base rails on all sides.
 - b. Holes shall be provided in the base rails for rigging shackles to facilitate maneuvering and overhead rigging.
 - c. Holes shall be provided in the base rail for moving the rooftop by fork truck.
 - d. Base rail shall be a minimum of 14 gauge thickness.

6. Condensate pan and connections:
 - a. Shall be a sloped condensate drain pan made of a non-corrosive material.
 - b. Shall comply with ASHRAE Standard 62.
 - c. Shall use a 1" x 11 1/2 NPT drain connection through the side of the drain pan. Connection shall be made per manufacturer's recommendations.
 7. Electrical Connections
 - a. All unit power wiring shall enter unit cabinet at a single, factory-prepared, knockout location.
 - b. Thru-the-base capability
 - i. Standard unit shall have a thru-the-base electrical location(s) using a raised, embossed portion of the unit basepan.
 - ii. No basepan penetration, other than those authorized by the manufacturer, is permitted.
 8. Component access panels (standard)
 - a. Cabinet panels shall be easily removable for servicing.
 - b. Stainless steel metal hinges are standard on all doors.
- 23 81 19.13.J. Coils
1. Standard Aluminum/Copper Coils:
 - a. Standard evaporator coils shall have aluminum lanced plate fins mechanically bonded to seamless internally grooved copper tubes with all joints brazed.
 - b. Evaporator and condenser coils shall be leak tested to 150 psig, pressure tested to 550 psig, and qualified to UL 1995 burst test at 2,200 psi.
 - c. Condenser coils shall be aluminum MicroChannel coils.
- 23 81 19.13.K. Refrigerant Components
1. Refrigerant circuit shall include the following control, safety, and maintenance features:
 - a. Capillary tubes.
 - b. Refrigerant filter drier.
 - c. Service gauge connections on suction and discharge lines.
 - d. Pressure gauge access through an access port in the front and rear panel of the unit.
 2. Compressors
 - a. Unit shall use one fully hermetic, scroll compressor for each independent refrigeration circuit.
 - b. Compressor motors shall be cooled by refrigerant gas passing through motor windings.
 - c. Compressors shall be internally protected from high discharge temperature conditions. Advanced Scroll Temperature Protection on 240 sizes.
 - d. Compressors shall be protected from an over-temperature and over-amperage conditions by an internal, motor overload device.
 - e. Compressor shall be factory mounted on rubber grommets.
 - f. Compressor motors shall have internal line break thermal and current overload protection.
 - g. Crankcase heaters shall not be required for normal operating range.
- 23 81 19.13.L. Filter Section
1. Filters access is specified in the unit cabinet section of this specification.
 2. Filters shall be held in place by sliding filter tray, facilitating easy removal and installation.
 3. Shall consist of factory-installed, low velocity, throw-away 2-in. thick fiberglass filters.
 4. Filter face velocity shall not exceed 365 fpm at nominal airflows.
 5. Filters shall be standard, commercially available sizes.
 6. Only one size filter per unit is allowed.
- 23 81 19.13.M. Evaporator Fan and Motor
1. Evaporator fan motor:
 - a. Shall have permanently lubricated bearings.
 - b. Shall have inherent automatic-reset thermal overload protection.
 - c. Shall have a maximum continuous bhp rating for continuous duty operation; no safety factors above that rating shall be required.

2. Belt-driven Evaporator Fan:

- a. Belt drive shall include an adjustable-pitch motor pulley.
- b. Shall use sealed, permanently lubricated ball-bearing type.
- c. Blower fan shall be double-inlet type with forward-curved blades.
- d. Shall be constructed from steel with a corrosion resistant finish and dynamically balanced.

23 81 19.13.N. Condenser Fans and Motors

1. Condenser fan motors:

- a. Shall be a totally enclosed motor.
- b. Shall use permanently lubricated bearings.
- c. Shall have inherent thermal overload protection with an automatic reset feature.
- d. Shall use a shaft-down design. Shaft-up designs including those with “rain-slinger devices” shall not be allowed.

2. Condenser Fans shall:

- a. Shall be a direct-driven propeller type fan
- b. Shall have aluminum blades riveted to corrosion-resistant steel spiders and shall be dynamically balanced.

23 81 19.13.O. Special Features

1. Integrated Economizers:

- a. Integrated, gear-driven parallel modulating blade design type capable of simultaneous economizer and compressor operation.
- b. Independent modules for vertical or horizontal return configurations shall be available. Vertical return modules shall be available as a factory installed option.
- c. Damper blades shall be galvanized steel with metal gears. Plastic or composite blades on intake or return shall not be acceptable.
- d. Shall include all hardware and controls to provide free cooling with outdoor air when temperature and/or humidity are below setpoints.
- e. Shall be equipped with gear driven dampers for both the outdoor ventilation air and the return air for positive air stream control.
- f. Shall be capable of introducing up to 100% outdoor air.
- g. Shall be equipped with a barometric relief damper capable of relieving up to 100% return air.
- h. Shall be designed to close damper(s) during loss-of-power situations with spring return built into motor.
- i. An outdoor single enthalpy sensor shall be provided as standard. Outdoor air enthalpy set point shall be adjustable and shall range from the enthalpy equivalent of 63°F @ 50% rh to 73°F @ 50% rh. Additional sensor options shall be available as accessories.
- j. The economizer controller shall also provide control of an accessory power exhaust unit function. Factory set at 70%, with a range of 0% to 100%.
- k. The economizer shall maintain minimum airflow into the building during occupied period and provide design ventilation rate for full occupancy. A remote potentiometer may be used to override the damper set point.
- l. Economizer controller shall accept a 2-10Vdc CO₂ sensor input for IAQ/DCV control. In this mode, dampers shall modulate the outdoor-air damper to provide ventilation based on the sensor input.
- m. Actuator shall be direct coupled to economizer gear. No linkage arms or control rods shall be acceptable.
- n. Economizer controller shall provide indications when in free cooling mode, in the DCV mode, or the exhaust fan contact is closed.

2. Two-Position Damper

- a. Damper shall be a Two-Position Damper. Damper travel shall be from the full closed position to the field adjustable %-open setpoint.
- b. Damper shall include adjustable damper travel from 25% to 100% (full open).
- c. Damper shall include single or dual blade, gear driven damper and actuator motor.
- d. Actuator shall be direct coupled to economizer gear. No linkage arms or control rods shall be acceptable.
- e. Damper will admit up to 100% outdoor air for applicable rooftop units.
- f. Damper shall close upon indoor (evaporator) fan shutoff and/or loss of power.
- g. The damper actuator shall plug into the rooftop unit’s wiring harness plug. No hard wiring shall be required.
- h. Outside air hood shall include aluminum water entrainment filter.

3. Manual damper
 - a. Manual damper package shall consist of damper, air inlet screen, and rain hood which can be preset to admit up to 50% outdoor air for year round ventilation.
4. Head Pressure Control Package
 - a. Controller shall control coil head pressure by condenser-fan cycling.
5. Convenience Outlet:
 - a. Non-Powered convenience outlet.
 - b. Outlet shall be powered from a separate 115-120v power source.
 - c. A transformer shall not be included.
 - d. Outlet shall be field-installed and internally mounted with easily accessible 115-v female receptacle.
 - e. Outlet shall include 15 amp GFI receptacles.
 - f. Outlet shall be accessible from outside the unit.
6. Thru-the-Base Connectors:
 - a. Kits shall provide connectors to permit electrical connections to be brought to the unit through the unit basepan.
7. Propeller Power Exhaust:
 - a. Power exhaust shall be used in conjunction with an integrated economizer.
 - b. Independent modules for vertical or horizontal return configurations shall be available.
 - c. Horizontal power exhaust is shall be mounted in return ductwork.
 - d. Power exhaust shall be controlled by economizer controller operation. Exhaust fans shall be energized when dampers open past the 0-100% adjustable setpoint on the economizer control.
8. Roof Curbs (Vertical):
 - a. Full perimeter roof curb with exhaust capability providing separate airstreams for energy recovery from the exhaust air without supply air contamination.
 - b. Formed galvanized steel with wood nailer strip and shall be capable of supporting entire unit weight.
 - c. Permits installation and securing of ductwork to curb prior to mounting unit on the curb.
9. Outdoor Air Enthalpy Sensor:
 - a. The outdoor air enthalpy sensor shall be used to provide single enthalpy control. When used in conjunction with a return air enthalpy sensor, the unit will provide differential enthalpy control. The sensor allows the unit to determine if outside air is suitable for free cooling.
10. Return Air Enthalpy Sensor:
 - a. The return air enthalpy sensor shall be used in conjunction with an outdoor air enthalpy sensor to provide differential enthalpy control.
11. Indoor Air Quality (CO₂) Sensor:
 - a. Shall be able to provide demand ventilation indoor air quality (IAQ) control.
 - b. The IAQ sensor shall be available in wall mount with LED display. The set point shall have adjustment capability.
12. Smoke detectors:
 - a. Shall be a Four-Wire Controller and Detector.
 - b. Shall be environmental compensated with differential sensing for reliable, stable, and drift-free sensitivity.
 - c. Shall use magnet-activated test/reset sensor switches.
 - d. Shall have tool-less connection terminal access.
 - e. Shall have a recessed momentary switch for testing and resetting the detector.
 - f. Controller shall include:
 - i. One set of normally open alarm initiation contacts for connection to an initiating device circuit on a fire alarm control panel
 - ii. Two Form-C auxiliary alarm relays for interface with rooftop unit or other equipment.
 - iii. One Form-C supervision (trouble) relay to control the operation of the Trouble LED on a remote test/reset station.
 - iv. Capable of direct connection to two individual detector modules.
 - v. Can be wired to up to 14 other duct smoke detectors for multiple fan shutdown applications.

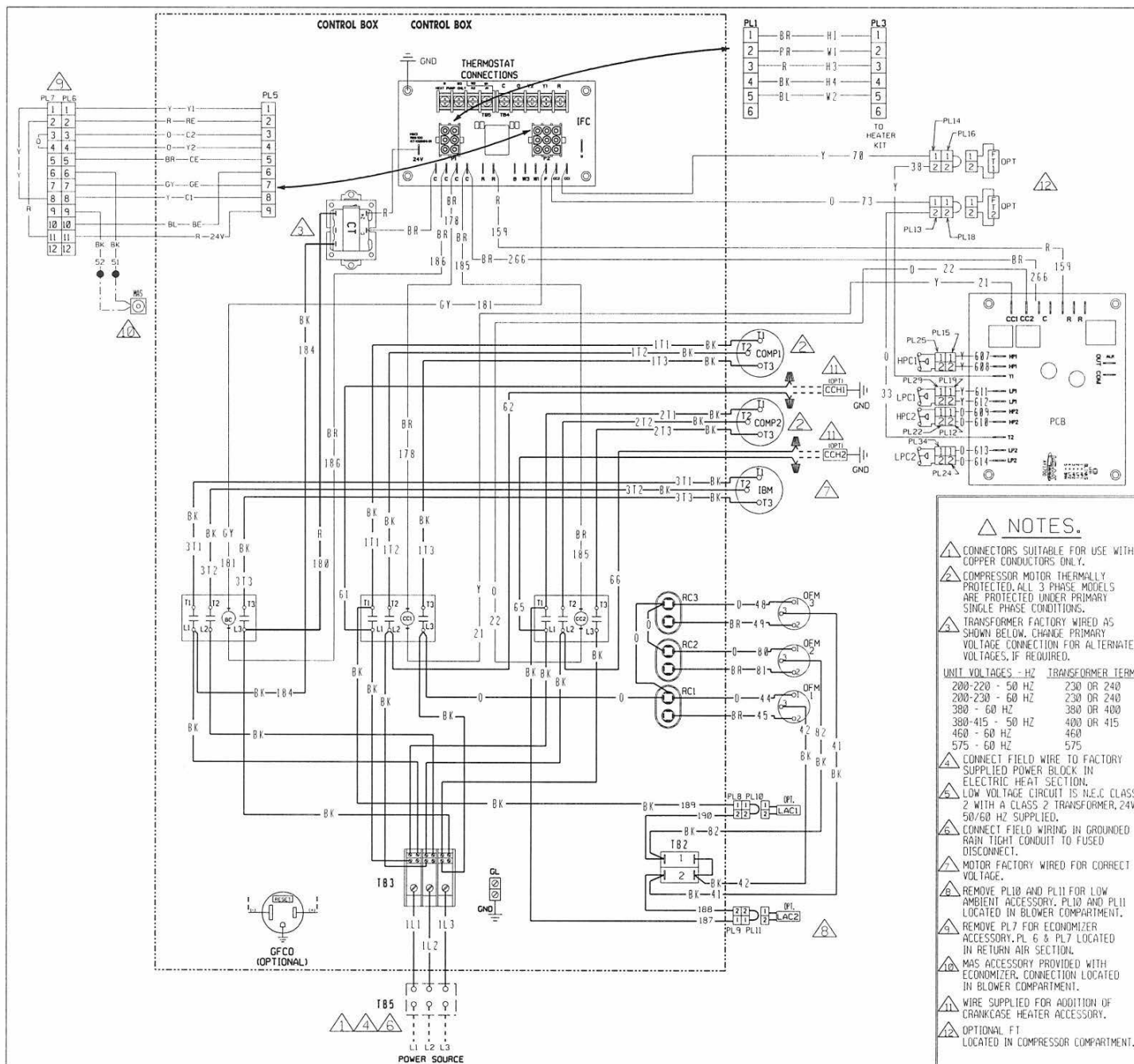

- △ NOTES.**
- △ CONNECTORS SUITABLE FOR USE WITH COPPER CONDUCTORS ONLY.
 - △ COMPRESSOR MOTOR THERMALLY PROTECTED. ALL 3 PHASE MODELS ARE PROTECTED UNDER PRIMARY SINGLE PHASE CONDITIONS.
 - △ TRANSFORMER FACTORY WIRING AS SHOWN BELOW. CHANGE PRIMARY VOLTAGES, IF REQUIRED.
- | UNIT VOLTAGES - HZ | TRANSFORMER TERM. |
|--------------------|-------------------|
| 200-220 - 50 HZ | 230 OR 240 |
| 200-230 - 60 HZ | 230 OR 240 |
| 380 - 60 HZ | 380 OR 400 |
| 380-415 - 50 HZ | 400 OR 415 |
| 460 - 60 HZ | 460 |
| 575 - 60 HZ | 575 |
- △ 4 CONNECT FIELD WIRE TO FACTORY SUPPLIED POWER BLOCK IN ELECTRIC HEAT SECTION.
 - △ 5 LOW VOLTAGE CIRCUIT IS N.E.C. CLASS 2 WITH A CLASS 2 TRANSFORMER, 24V, 50/60 HZ SUPPLIED.
 - △ 6 CONNECT FIELD WIRING IN GROUNDED RAIN TIGHT CONDUIT TO FUSED DISCONNECT.
 - △ 7 MOTOR FACTORY WIRING FOR CORRECT VOLTAGE.
 - △ 8 REMOVE PL10 AND PL11 FOR LOW AMBIENT ACCESSORY. PL10 AND PL11 LOCATED IN BLOWER COMPARTMENT.
 - △ 9 REMOVE PL7 FOR ECONOMIZER ACCESSORY. PL 6 & PL7 LOCATED IN RETURN AIR SECTION.
 - △ 10 MAS ACCESSORY PROVIDED WITH ECONOMIZER. CONNECTION LOCATED IN BLOWER COMPARTMENT.
 - △ 11 WIRE SUPPLIED FOR ADDITION OF CRANKCASE HEATER ACCESSORY.
 - △ 12 OPTIONAL FT. LOCATED IN COMPRESSOR COMPARTMENT.

COMPONENT CODE		WIRING INFORMATION		WIRE COLOR CODE	
BC	BLOWER CONTACTOR	LINE VOLTAGE	_____	BK	BLACK
CC	COMPRESSOR CONTACTOR	-FACTORY STANDARD	_____	BR	BROWN
CH	CRANKCASE HEATER	-FACTORY OPTION	-----	BL	BLUE
COMP	COMPRESSOR	-FIELD INSTALLED	-----	G	GREEN
CT	CONTROL TRANSFORMER	LOW VOLTAGE	_____	GY	GRAY
FT	FREEZE STAT	-FACTORY STANDARD	_____		
GFCO	GROUND FAULT CONVENIENCE OUTLET	-FACTORY OPTION	-----		
GL	GROUND LUG	-FIELD INSTALLED	-----		
GND	GROUND	REPLACEMENT WIRE	_____		
HPC	HIGH PRESSURE CONTROL	-MUST BE THE SAME SIZE AND TYPE OF INSULATION AS ORIGINAL (105 C° MIN.)	_____		
IFB	INDOOR BLOWER MOTOR BELT DRIVE	WARNING	_____		
IFC	INTEGRATED FURNACE CONTROL	-CABINET MUST BE PERMANENTLY GROUNDED AND CONFORM TO I.E.C., N.E.C., C.E.C. AND LOCAL CODES AS APPLICABLE.	_____		
IFC	INTEGRATED FURNACE CONTROL		_____		
LAC	LOW AMBIENT COOLING CONTROL		_____		
LPC	LOW PRESSURE CONTROL		_____		
MAS	MIX AIR SENSOR		_____		
OFM	OUTDOOR FAN MOTOR		_____		
RC	RUN CAPACITOR		_____		
TDC	TIME DELAY CONTROL		_____		
PCB	PRESSURE CONTROL BOARD		_____		
PL	PLUG		_____		
PT	POWER TRANSFORMER		_____		
W	WIRE NUT		_____		

WIRING DIAGRAM
RLKL-B180/240
208-230/460/575V 3 PH, 60 HZ.
200-220/380-415 3PH, 50 HZ.
PACKAGED A/C

DR. BY: MGR APP. BY: *MGR* DATE: 8-14-12 DWG. NO.: 90-42517-52 REV: 01

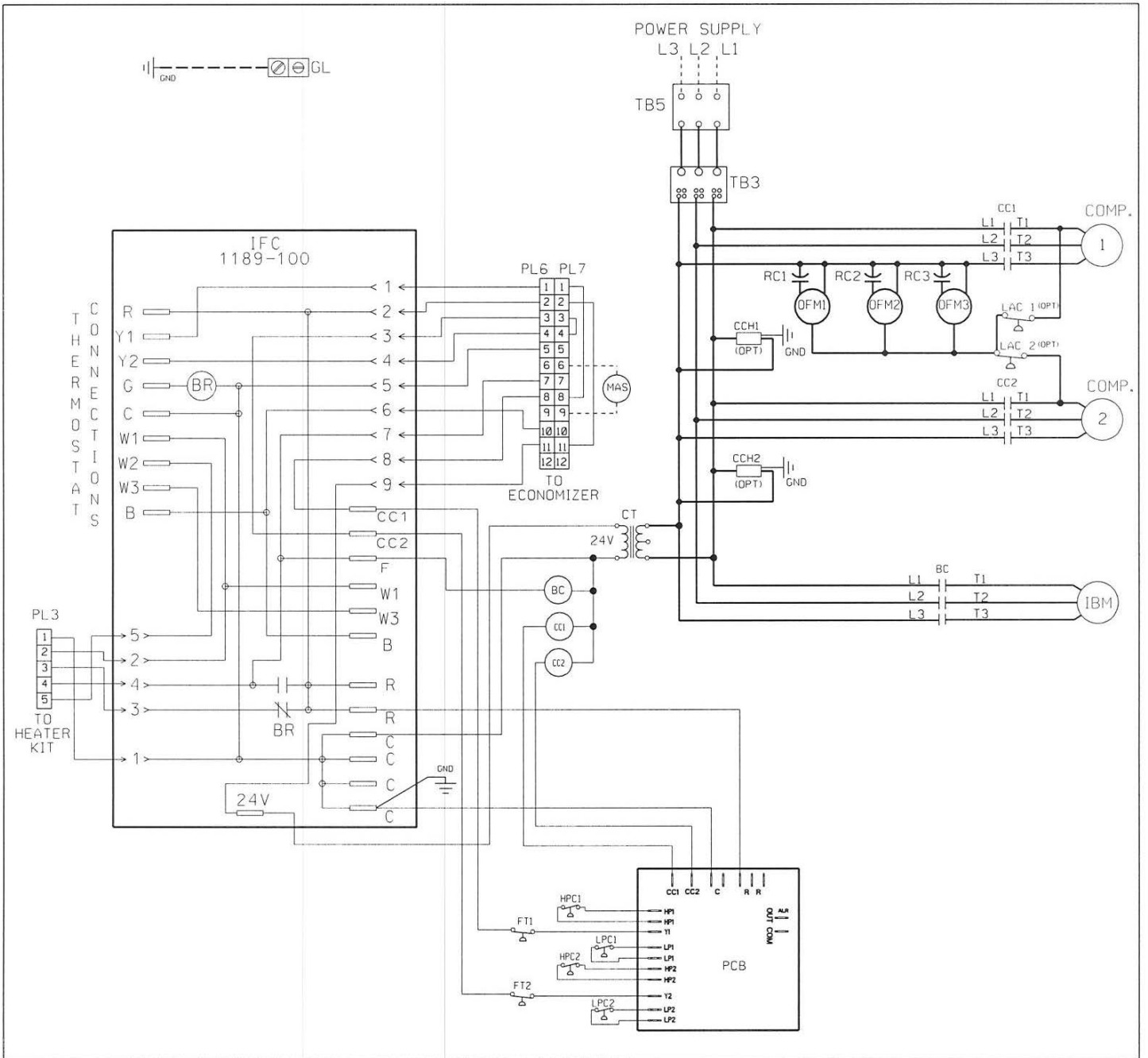

COMPONENT CODE

BC	BLOWER MOTOR CONTACTOR	MAS	MIXED AIR SENSOR
BR	BLOWER RELAY	OFM	OUTDOOR FAN MOTOR
CC	COMPRESSOR CONTACTOR	DPT	OPTIONAL
CCH	CRANKCASE HEATER	PCB	PRESSURE CONTROL BOARD
COMP	COMPRESSOR	PL	PLUG
CT	CONTROL TRANSFORMER	RC	RUN CAPACITOR
FT	FREEZE STAT	TB	TERMINAL BLOCK
GL	GROUND LUG		
GND	GROUND		
HPC	HIGH PRESSURE CONTROL		
IBM	INDOOR BLOWER MOTOR		
IFC	INTEGRATED FURNACE CONTROL		
LAC	LOW AMBIENT CONTROL		
LPC	LOW PRESSURE CONTROL		

WIRING INFORMATION

LINE VOLTAGE
 -FACTORY STANDARD —————
 -FACTORY OPTION - - - - -
 -FIELD INSTALLED - · - · - ·

LOW VOLTAGE
 -FACTORY STANDARD —————
 -FACTORY OPTION - - - - -
 -FIELD INSTALLED - · - · - ·

REPLACEMENT WIRE
 -MUST BE THE SAME SIZE AND TYPE OF INSULATION AS ORIGINAL (105° C MIN.)

WARNING
 -CABINET MUST BE PERMANENTLY GROUNDED AND CONFORM TO I.E.C., N.E.C., C.E.C., NATIONAL WIRING REGULATIONS, AND LOCAL CODES AS APPLICABLE.

WIRE COLOR CODE

BK	BLACK	O	ORANGE
BR	BROWN	PR	PURPLE
BL	BLUE	R	RED
G	GREEN	W	WHITE
GY	GRAY	Y	YELLOW

WIRING SCHEMATIC

RLKL-B180/240
 208-230V, 3PH, 60HZ. / 460V, 3PH, 60HZ.
 575V, 3PH, 60 HZ.
 200-220/380-415V 3 PH, 50 HZ.
 PACKAGED A/C

DR. BY	APP. BY	DATE	DWG. NO.	REV
MGR	ms	8-16-12	90-42517-53	00

BEFORE PURCHASING THIS APPLIANCE, READ IMPORTANT ENERGY COST AND EFFICIENCY INFORMATION AVAILABLE FROM YOUR RETAILER.

GENERAL TERMS OF LIMITED WARRANTY*

Rheem will furnish a replacement for any part of this product which fails in normal use and service within the applicable periods stated, in accordance with the terms of the limited warranty.

*For complete details of the Limited and Conditional Warranties, including applicable terms and conditions, contact your local contractor or the Manufacturer for a copy of the product warranty certificate.

Compressor

1 & 3 Phase, Commercial Applications.....Five (5) Years

Parts

3 Phase, Commercial Applications.....One (1) Year



The new degree of comfort.™

In keeping with its policy of continuous progress and product improvement, Rheem reserves the right to make changes without notice.

Rheem Heating, Cooling & Water Heating • P.O. Box 17010
Fort Smith, Arkansas 72917 • www.rheem.com

Rheem Canada Ltd./Ltée • 125 Edgeware Road, Unit 1
Brampton, Ontario • L6Y 0P5



INTEGRATED AIR & WATER

PRINTED IN U.S.A 10/12 QG FORM NO. S11-960 REV. 1