



Air

Package Air Conditioner  
RLKL-B Series

The new degree of comfort.™



## Rheem *Commercial Value Series* Package Air Conditioner



### **RLKL-B High Efficiency Series**

Nominal Sizes 7.5, 10 & 12.5 Tons

[26.4, 35.2 & 44.0 kW]

ASHRAE 90.1-2010 Compliant Model



*"Proper sizing and installation of equipment is critical to achieve optimal performance. Ask your Contractor for details or visit [www.energystar.gov](http://www.energystar.gov)."*



INTEGRATED AIR & WATER

## TABLE OF CONTENTS

Unit Features & Benefits .....	3-7
Selection Procedure .....	8
Model Number Identification .....	9
Options .....	10
General Data	
RLKL-B Series .....	11-16
General Data Notes .....	17
Gross Systems Performance Data	
RLKL-B Series .....	18-19
Airflow Performance	
RLKL-B Series .....	20-22
Electrical Data	
RLKL-B Series .....	23-25
Electric Heater Kits .....	26-31
Dimensional Data .....	32-35
Accessories .....	36-55
Mechanical Specifications .....	56-57
Wiring Diagrams .....	58-61
Limited Warranty .....	62

## These quality features are included in the Rheem Package Air Conditioner Unit

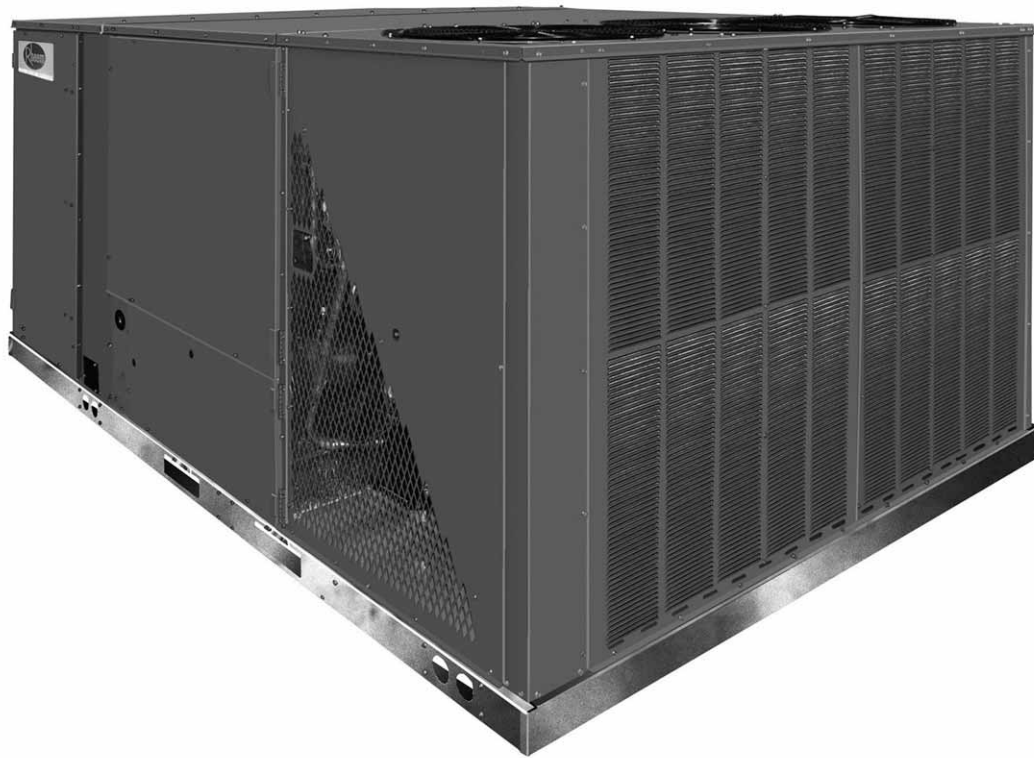

### STANDARD FEATURES INCLUDE:

- R-410A HFC refrigerant.
- Complete factory charged, wired and run tested.
- Scroll compressors with internal line break overload and high-pressure protection.
- Single stage compressor.
- Convertible airflow.
- Orifice metering system on 7.5 and 10 ton. TXV metering on 12.5 ton.
- High Pressure and Low Pressure/Loss of charge protection standard on all models.
- Solid Core liquid line filter drier on each circuit.
- Single slab, single pass designed evaporator and condenser coils facilitate easy cleaning for maintained high efficiencies.
- MicroChannel outdoor coil.
- Cooling operation up to 125 degree F ambient.
- Foil faced insulation encapsulated throughout entire unit minimizes airborne fibers from the air stream.
- Mechanical fasteners, door with heavy-duty gasketing.
- Slide Out Indoor fan assembly for added service convenience.
- Powder Paint Finish meets ASTM B117 steel coated on each side for maximum protection. G90 galvanized.
- One piece top cover and one piece base pan with drawn supply and return opening for superior water management.
- Forkable base rails for easy handling and lifting.
- Single point electrical connections.
- Internally sloped slide out condensate pan conforms to ASHRAE 62 standards.
- High performance belt drive motor with variable pitch pulleys and quick adjust belt system.
- Permanently lubricated evaporator and condenser motors.
- Condenser motors are internally protected, totally enclosed with shaft down design.
- 2 inch filter standard with slide out design.
- 24 volt control system with resettable circuit breakers.
- Colored and labeled wiring.
- Molded compressor plug.
- Supplemental electric heat provides 100% efficient heating.

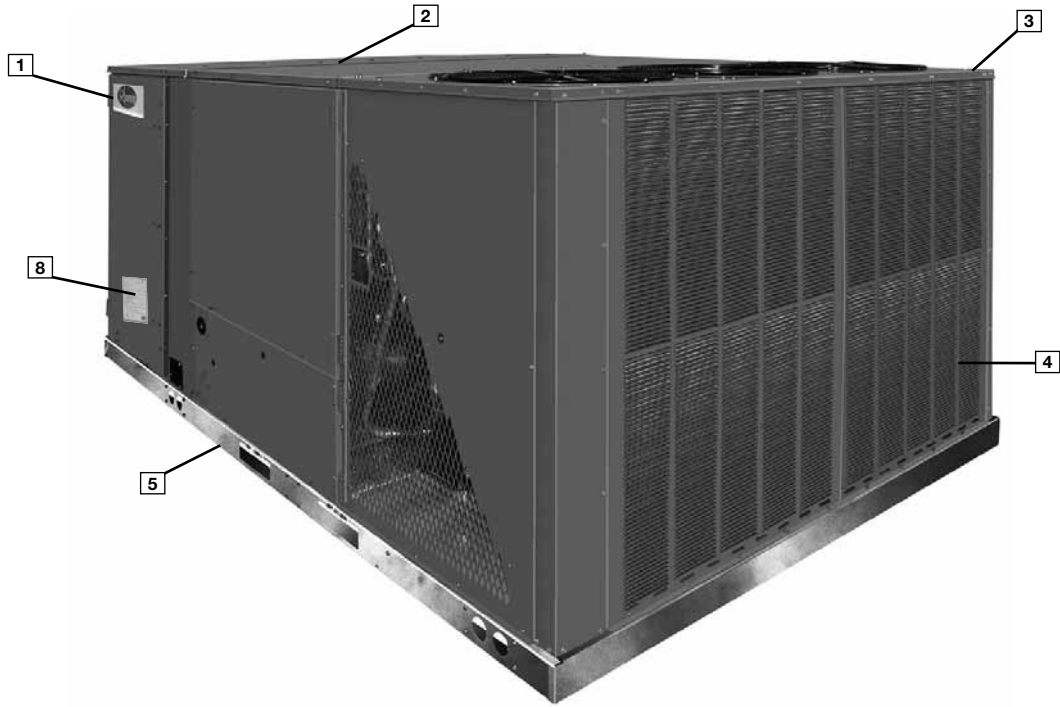

Rheem Package equipment is designed from the ground up with the latest features and benefits required to compete in today's market. The clean design stands alone in the industry and is a testament to the quality, reliability, ease of installation and serviceability that goes into each unit. Outwardly, the large Rheem *Commercial Series*™ label (1) identifies the brand to the customer. The sheet-metal cabinet (2) uses nothing less than 18-gauge material for structural components with an underlying coat of G90. To ensure the leak-proof integrity of these units, the design utilizes a one-piece top with a 1/8" drip lip (3), gasket-protected panels and screws. The Rheem hail guard (optional) (4) is its trademark, and sets the standard for coil protection in the industry. Every Rheem package unit uses the toughest finish in the industry, using electro deposition baked-on enamel tested to withstand a rigorous 1000-hour salt spray test, per ASTM B117.

Anything built to last must start with the right foundation. In this case, the foundation is 14-gauge, commercial-grade, full-perimeter base rails (5), which integrate fork slots and rigging holes to save set-up time on the job site. The base pan is stamped, which forms a 1-1/8" flange around the supply and return cover and has eliminated the worry of water entering the conditioned space (6). The insulation has been placed on the underside of the basepan, removing areas that would allow for potential moisture accumulation, which can facilitate growth of harmful bacteria. All insulation is secured with both adhesive and mechanical fasteners, and all edges are hidden. The drainpan (7) is made of material that resists the growth of harmful bacteria and is sloped for the latest IAQ benefits. Furthermore, the drain pan slides out for easy cleaning.



During development, each unit was tested to U.L. 1995, AHRI 340-370 and other Rheem-required reliability tests. Rheem adheres to stringent ISO 9002 quality procedures, and each unit bears the U.L. and AHRI certification labels located on the unit nameplate. Contractors can rest assured that when a Rheem package unit arrives at the job, it is ready to go with a factory charge and quality checks. Each unit also proudly displays the "Made in the USA" designation.

Access to all major compartments is from the front of the unit, including the filter and electrical compartment, blower compartment, heating section, and outdoor section. Each compartment has mechanical fasteners. Each panel is permanently embossed with the compartment name (control/filter access, blower access and electric heat access).

Electrical and filter compartment access is through a large, mechanically fastened panel. On the outside of the panel is the unit nameplate, which contains the model and serial number, electrical data and other important unit information.

The unit charging chart is located on the inside of the electrical and filter compartment door. Electrical wiring diagrams are found on the control box cover, which allows contractors to move them to more readable locations. To the right of the control box the model and serial number can be found. Having this information on the inside will assure model identification for the life of the product. The production line quality test assurance label is also placed in this location (8). The two-inch throwaway filters (9) are easily removed on a tracked system for easy replacement.



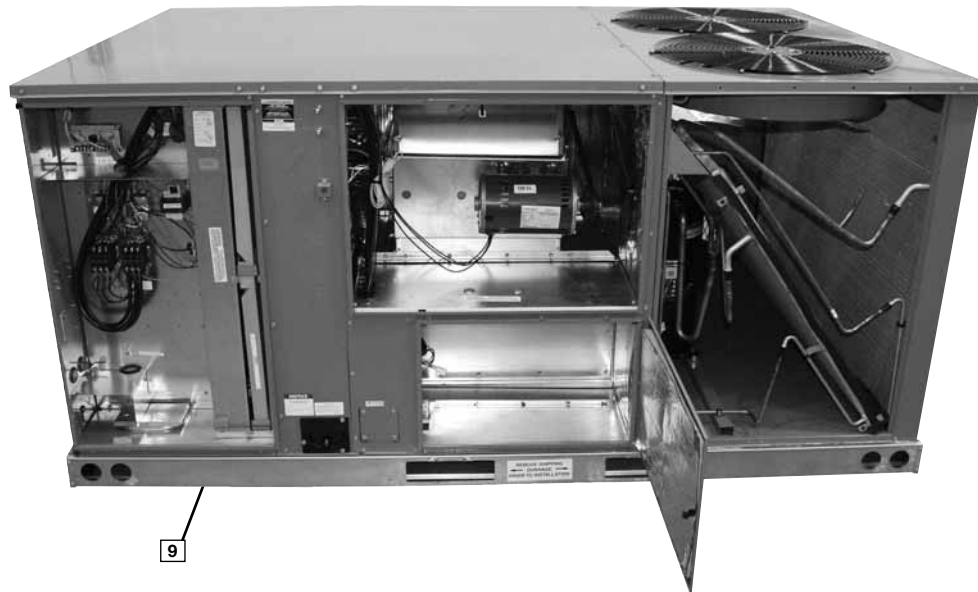

Inside the control box (10), each electrical component is clearly identified with a label that matches the component to the wire diagram for ease of trouble shooting. All wiring is numbered on each end of the termination and color-coded to match the wiring diagram. The control transformer has a low voltage circuit breaker that trips if a low voltage electrical short occurs. There is a blower contactor and compressor for each compressor.



For added convenience in the field, a factory-installed convenience outlet (11) is available. Low and High voltage can enter either from the side or through the base. Low-voltage connections are made integrated cooling control. The high-voltage connection is terminated at the number 1 compressor contactor. The suggested mounting for the field-installed disconnect is on the exterior side of the electrical control box.



To the right of the electrical and filter compartment are the externally mounted gauge ports, which are permanently identified by embossed wording that clearly identifies the compressor circuit, high pressure connection and low pressure connection (12). With the gauge ports mounted externally, an accurate diagnostic of system operation can be performed quickly and easily. The blower compartment is to the right of the gauge ports and can be



accessed by removing mechanical turn fasteners. To allow easy maintenance of the blower assembly, the entire assembly easily slides out by removing the 3/8" screws from the blower retention bracket. The adjustable motor pulley (13) can easily be adjusted by loosening the bolts on either side of the motor mount. Removing the bolts allows for easy removal of the blower pulley by pushing the blower assembly up to loosen the belt. Once the pulley is removed, the motor sheave can be adjusted to the desired number of turns, ranging from 0 to 6 turns open. Where the demands for the job require high static, Rheem has high-static drives available that deliver nominal airflow up to 2" of static. By referring to the airflow performance tables listed in the installation instructions, proper static pressure and CFM requirements can be dialed in. The scroll housing (14) and blower scroll provide quiet and efficient airflow. The blower sheave is secured by an "H" bushing which firmly secures the pulley to the blower shaft for years of trouble-free operation. The "H" bushing allows for easy removal of the blower pulley from the shaft, as opposed to the use of a set screw, which can score the shaft, creating burrs that make blower-pulley removal difficult.

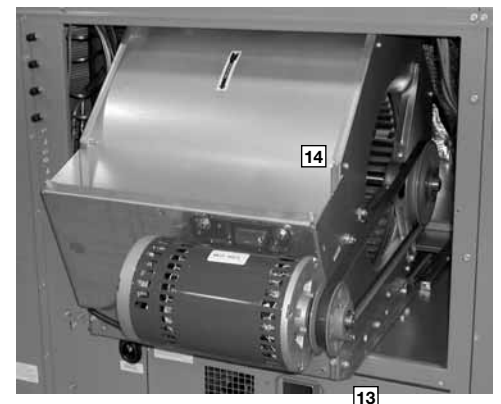

Also inside the blower compartment is the low-ambient control (15), low-pressure switch (16), high-pressure switch (17) and freeze stat refrigerant safety device (18) (optional). The low-ambient control allows for operation of the compressor down to 0 degrees ambient temperature by cycling the outdoor fans on high pressure. The high-pressure switch will shut off the compressors if pressures exceeds, 610 PSIG are detected, this may occur if the outdoor fan motor fails. The low-pressure switch shuts off the compressors if low pressure is detected due to loss of charge. The freeze stat protects the compressor if the evaporator coil gets too cold (below freezing) due to low airflow. Each factory-installed option is brazed into the appropriate high or low side and wired appropriately. Use of polarized plugs and sharder fittings allow for easy field installation.

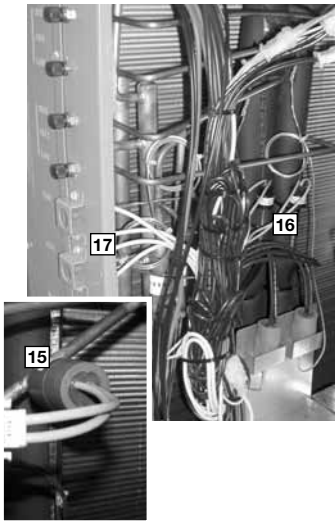

Inside the blower compartment the interlaced evaporator can also be viewed. The evaporator uses enhanced fin technology for maximum heat transfer. The fixed orifice metering device (TXV's on 12.5 ton) assures even distribution of refrigerant throughout the evaporator. MicroChannel technology is used on outdoor coil.

Wiring throughout the unit is neatly bundled and routed. Where wire harnesses go through the condenser bulkhead or blower deck, a molded wire harness assembly (19) provides an air-tight and water-tight seal, and provides strain relief. Care is also taken to tuck raw edges of insulation behind sheet metal to improve indoor air quality.

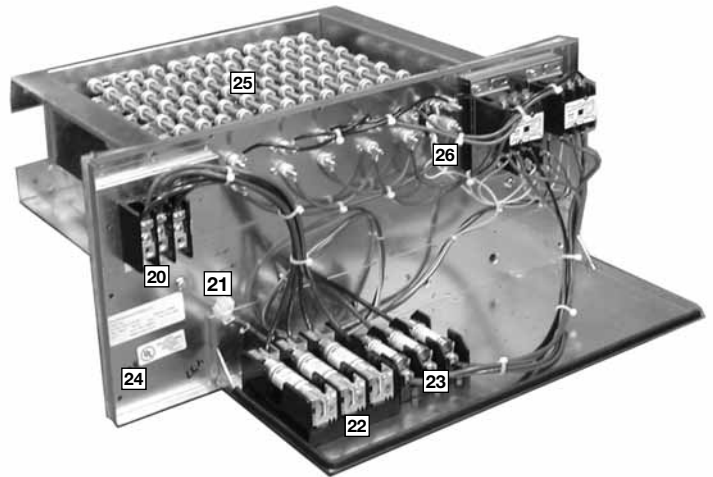
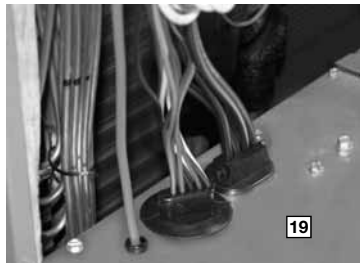

The heating compartment contains the latest electric furnace technology on the market. The 100% efficient electric furnace can be factory-installed or easily field-installed. Built with ease-of-installation in mind, the electric furnace is completely wired for slide-in, plug-and-play installation in the field. With choices of up to six kilowatt offerings, the contractor is assured to get the correct amount of heating output to meet the designed heating load.

Power hook-up in the field is easy with single-point wiring to a terminal block (20) and a polarized plug for the low-voltage connection (21). The electric furnace comes with fuses for the unit (22) and for the electric furnace (23), and is UL certified (24). The electric heating elements are of a wound-wire construction (25) and isolated with ceramic bushings. The limit switch (26) protects the design from over-temperature conditions. Each electric furnace has the capability to be converted from single-stage operation to two-stage operation by removing a jumper on the low-voltage terminal strip.

The compressor compartment houses the heart-beat of the unit. The scroll compressor (28) is known for its long life, and for reliable, quiet, and efficient operation. The suction and discharge lines are designed with shock loops (29) to absorb the strain and stress that the starting torque, steady state operation, and shut down cycle impose on the refrigerant tubing.

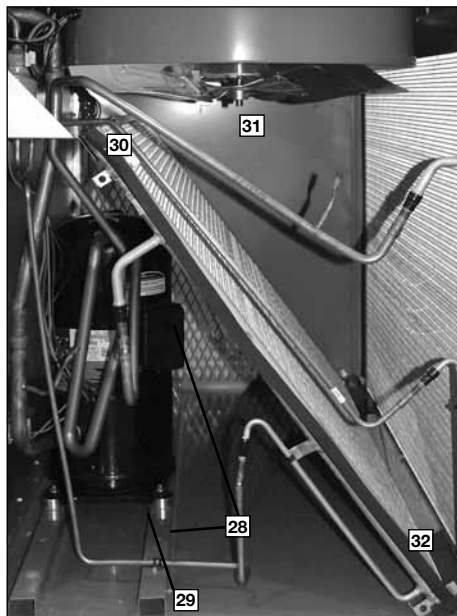

Each unit comes standard with filter dryer (30). The condenser fan motor (31) can easily be accessed and maintained through the compressor compartment. The polarized plug connection allows the motor to be changed quickly and eliminates the need to snake wires through the unit.

The outdoor coil uses the latest MicroChannel technology (32) for the most effective method of heat transfer. The outdoor coil is protected by optional louvered panels, which allow unobstructed airflow while protecting the unit from both Mother Nature and vandalism.

Each unit is designed for both downflow or horizontal applications (33) for job configuration flexibility. The return air compartment can also contain an economizer (34).

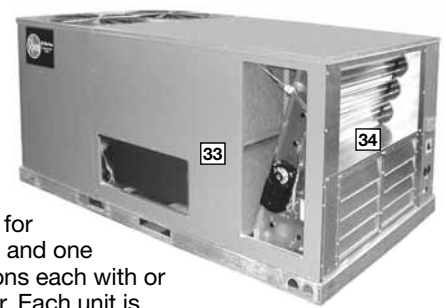

Four models exits, one for downflow applications, and one for horizontal applications each with or without smoke detector. Each unit is pre-wired for the economizer to allow quick plug-in installation. The economizer is also available as a factory-installed option. Power Exhaust is easily field-installed. The economizer, which provides free cooling when outdoor conditions are suitable and also provides fresh air to meet local requirements, comes standard with single enthalpy controls. The controls can be upgraded to dual enthalpy easily in the field. The direct drive actuator combined with gear drive dampers has eliminated the need for linkage adjustment in the field. The economizer control has a minimum position setpoint, an outdoor-air setpoint, a mix-air setpoint, and a CO<sup>2</sup> setpoint. Barometric relief is standard on all economizers. The power exhaust is housed in the barometric relief opening and is easily slipped in with a plug-in assembly. The wire harness to the economizer also has accommodations for a smoke detector.

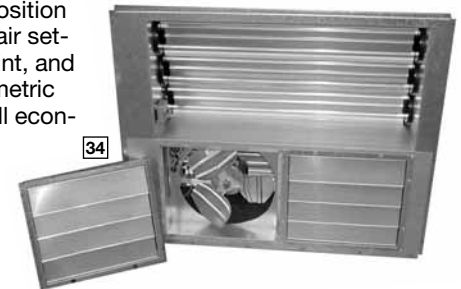

The Rheem roofcurb (35) is made for toolless assembly at the jobsite by engaging a pin into the hinged corner brackets into the adjacent curb sides, which makes the assembly process quick and easy.





To select an RLKL- Cooling and Heating unit to meet a job requirement, follow this procedure, with example, using data supplied in this specification sheet.

**1. DETERMINE COOLING AND HEATING REQUIREMENTS AND SPECIFIC OPERATING CONDITIONS FROM PLANS AND SPECS.**

**Example:**

- Total cooling capacity— 106,000 BTUH [31.26 kW]
- Sensible cooling capacity— 82,000 BTUH [24.03 kW]
- Heating capacity— 150,000 BTUH [43.96 kW]
- \*Condenser Entering Air— 95°F [35°C] DB
- \*Evaporator Mixed Air Entering—65°F [18°C] WB;  
78°F [26°C] DB
- \*Indoor Air Flow (vertical)— 3600 CFM [1699 L/s]
- \*External Static Pressure— .40 in. WG

**2. SELECT UNIT TO MEET COOLING REQUIREMENTS.**

Since total cooling is within the range of a nominal 10 ton [35.2 kW] unit, enter cooling performance table at 95°F [35°C] DB condenser inlet air. Interpolate between 63°F [2°C] and 67°F [19°C] to determine total and sensible capacity and power input for 65°F [18°C] WB evap inlet air at 4000 CFM [1888 L/s] indoor air flow (table basis):

Total Capacity = 118,900 BTUH [34.80 kW]  
Sensible Capacity = 99,950 BTUH [29.29 kW]  
Power Input (Compressor and Cond. Fans) = 8,950 watts

Use formula [1.10 x CFM x (1 - DR) x (dbE - 80)] in note ① to determine sensible capacity at 80°F [26.7°C] DB evaporator entering air:

Sensible Capacity = 92,268 BTUH [27.24 kW]

**3. CORRECT CAPACITIES OF STEP 2 FOR ACTUAL AIR FLOW.**

Select factors from airflow correction table at 3600 CFM [1699 L/s] and apply to data obtained in step 2 to obtain gross capacity:

Total Capacity, 118,900 x .98 = 116,522 BTUH [34.15 kW]  
Sensible Capacity, 92,268 x .95 = 87,655 BTUH [25.67 kW]  
Power Input 11,650 x .99 = 8,861 Watts

These are Gross Capacities, not corrected for blower motor heat or power.

**4. DETERMINE BLOWER SPEED AND WATTS TO MEET SYSTEM DESIGN.**

Enter Indoor Blower performance table at 3600 CFM [1699 L/s]. Total ESP (external static pressure) per the spec of .40 in. includes the system duct and grilles. Add from the table "Component Air Resistance," .076 for wet coil, .13 for vertical air flow, for a total selection static pressure of .606 (.6) inches of water, and determine:

- RPM = 796
- WATTS = 1,650
- DRIVE = L (standard 2 H.P. motor)

**5. CALCULATE INDOOR BLOWER BTUH HEAT EFFECT FROM MOTOR WATTS, STEP 4.**

$$\text{BTUH} = 1,650 \times 3.412 = 5,630$$

**6. CALCULATE NET COOLING CAPACITIES, EQUAL TO GROSS CAPACITY, STEP 3, MINUS INDOOR BLOWER MOTOR HEAT.**

$$\text{Net Total Capacity} = 116,522 - 5,630 = 110,892 \text{ BTUH [32.5 kW]}$$

$$\text{Net Sensible Capacity} = 87,655 - 5,630 = 82,025 \text{ BTUH [24.04 kW]}$$

**7. CALCULATE UNIT INPUT AND JOB EER.**

$$\text{Total Power Input} = 88,610 \text{ (step 3)} + 1,650 \text{ (step 4)} = 10,511 \text{ Watts}$$

$$\text{EER} = \frac{\text{Net Total BTUH [kW] (step 6)}}{\text{Power Input, Watts (above)}} = \frac{110,892}{10,511} = 10.55$$

**8. SELECT UNIT HEATING CAPACITY.**

Units with heater kits section find unit heater kw and convert watts to BTU: add blower BTUH heat effect (step 5).

<u>CC51C</u>	<u>Heater Kit</u>
kW x 3412	= 163,776 BTUH [48.00 kW]
	+ 5,630 BTUH [1.65 kW]
Heating Capacity=	169,406 BTUH [49.65 kW]

\*NOTE: These operating conditions are typical of a commercial application in a 95°F/79°F [35°C/26°C] design area with indoor design of 76°F [24°C] DB and 50% RH and 10% ventilation air, with the unit roof mounted and centered on the zone it conditions by ducts.

[ ] Designates Metric Conversions







Air

**R L K L — B 120 C L 000 X X X**

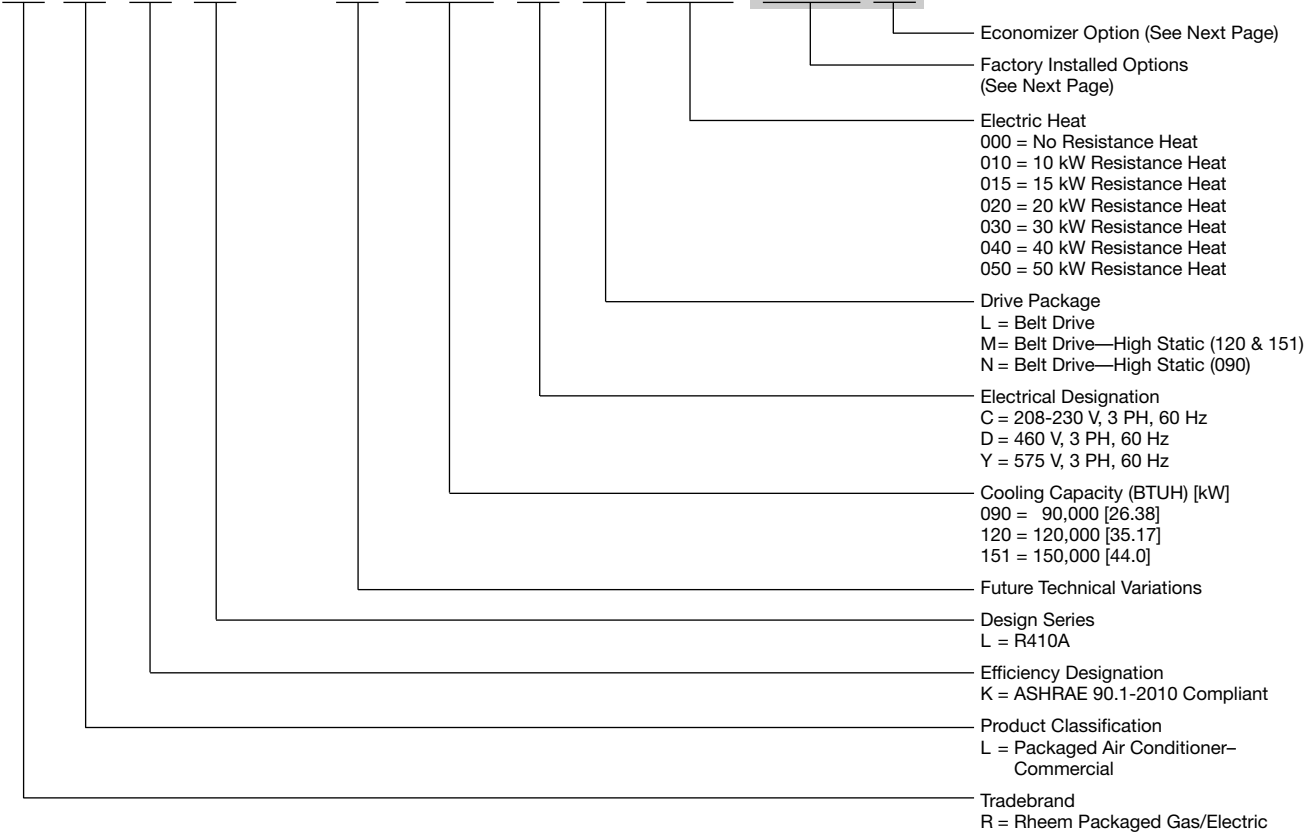

[ ] Designates Metric Conversions



## 7.5, 10, & 12.5 TON [26.4, 35.2 & 44.0 kW]

Option Code	Hail Guard	Non-Powered Convenience Outlet	Low Ambient/ Freeze Stat
AD	x		
AG		x	
AP			x
BY	x		x
BJ	x	x	
CX	x	x	x
JC		x	x

“x” indicates factory installed option.

## ECONOMIZER SELECTION FOR LKL 7.5, 10, & 12.5 TON [26.4, 35.2 & 44.0 kW]

Option Code	No Economizer	Single Enthalpy Economizer with Barometric Relief	Single Enthalpy Economizer with Barometric Relief and Smoke Detector
A	x		
F		x	
G			x

“x” indicates factory installed option.

## Instructions for Factory Installed Option(s) Selection

**Note:** Three characters following the model number will be utilized to designate a factory-installed option or combination of options. If no factory option(s) is required, nothing follows the model number.

**Step 1.** After a basic rooftop model is selected, choose a *two-character* option code from the FACTORY INSTALLED OPTION SELECTION TABLE.

Proceed to Step 2.

**Step 2.** The last option code character is utilized for factory-installed economizers. Choose a character from the FACTORY INSTALLED ECONOMIZER SELECTION TABLE.

## Examples:

RLKL-B120CL000 .....this unit has no factory installed options.

RLKL-B120CL000**ADA** .....this unit is equipped with *hail guards*.

RLKL-B120CL000**BYA** .....this unit is equipped with *hail guards, low ambient and unit freeze stat*.

RLKL-B120CL000**BYF** .....this unit is equipped as above *and* includes an *Economizer with single enthalpy sensor and with barometric relief*.

RLKL-B120CL000**AAG** .....this unit is equipped with an *Economizer with single enthalpy sensor and barometric relief with smoke detector*.

[ ] Designates Metric Conversions

## NOM. SIZES 7.5, 10, & 12.5 TON [26.4, 35.2 & 44.0 kW] ASHRAE 90.1-2010 COMPLIANT MODELS

Model RLKL- Series	B090CL	B090CM	B090CN	B090DL
<b>Cooling Performance<sup>1</sup></b>				<b>CONTINUED</b> →
Gross Cooling Capacity Btu [kW]	87,000 [25.49]	87,000 [25.49]	87,000 [25.49]	87,000 [25.49]
EER/SEER <sup>2</sup>	11.2/NA	11.2/NA	11.2/NA	11.2/NA
Nominal CFM/AHRI Rated CFM [L/s]	2800/2925 [1321/1380]	2800/2925 [1321/1380]	2800/2925 [1321/1380]	2800/2925 [1321/1380]
AHRI Net Cooling Capacity Btu [kW]	84,000 [24.61]	84,000 [24.61]	84,000 [24.61]	84,000 [24.61]
Net Sensible Capacity Btu [kW]	64,800 [18.99]	64,800 [18.99]	64,800 [18.99]	64,800 [18.99]
Net Latent Capacity Btu [kW]	19,200 [5.63]	19,200 [5.63]	19,200 [5.63]	19,200 [5.63]
IEER <sup>3</sup>	12.1	12.1	12.1	12.1
Net System Power kW	7.5	7.5	7.5	7.5
<b>Compressor</b>				
No./Type	1/Scroll	1/Scroll	1/Scroll	1/Scroll
<b>Outdoor Sound Rating (dB)<sup>4</sup></b>	88	88	88	88
<b>Outdoor Coil - Fin Type</b>	Louvered	Louvered	Louvered	Louvered
Tube Type	MicroChannel	MicroChannel	MicroChannel	MicroChannel
MicroChannel Depth in. [mm]	1 [25.4]	1 [25.4]	1 [25.4]	1 [25.4]
Face Area sq. ft. [sq. m]	13.5 [1.25]	13.5 [1.25]	13.5 [1.25]	13.5 [1.25]
Rows / FPI [FPcm]	1 / 23 [9]	1 / 23 [9]	1 / 23 [9]	1 / 23 [9]
<b>Indoor Coil - Fin Type</b>	Louvered	Louvered	Louvered	Louvered
Tube Type	Rifled	Rifled	Rifled	Rifled
Tube Size in. [mm]	0.375 [9.5]	0.375 [9.5]	0.375 [9.5]	0.375 [9.5]
Face Area sq. ft. [sq. m]	13.5 [1.25]	13.5 [1.25]	13.5 [1.25]	13.5 [1.25]
Rows / FPI [FPcm]	2 / 18 [7]	2 / 18 [7]	2 / 18 [7]	2 / 18 [7]
Refrigerant Control	Orifices	Orifices	Orifices	Orifices
Drain Connection No./Size in. [mm]	1/1 [25.4]	1/1 [25.4]	1/1 [25.4]	1/1 [25.4]
<b>Outdoor Fan - Type</b>	Propeller	Propeller	Propeller	Propeller
No. Used/Diameter in. [mm]	1/24 [609.6]	1/24 [609.6]	1/24 [609.6]	1/24 [609.6]
Drive Type/No. Speeds	Direct/1	Direct/1	Direct/1	Direct/1
CFM [L/s]	4500 [2124]	4500 [2124]	4500 [2124]	4500 [2124]
No. Motors/HP	1 at 1/2 HP	1 at 1/2 HP	1 at 1/2 HP	1 at 1/2 HP
Motor RPM	1075	1075	1075	1075
<b>Indoor Fan - Type</b>	FC Centrifugal	FC Centrifugal	FC Centrifugal	FC Centrifugal
No. Used/Diameter in. [mm]	1/15x15 [381x381]	1/15x15 [381x381]	1/15x15 [381x381]	1/15x15 [381x381]
Drive Type/No. Speeds	Belt/Variable	Belt/Variable	Belt/Variable	Belt/Variable
No. Motors	1	1	1	1
Motor HP	2	2	3	2
Motor RPM	1725	1725	1725	1725
Motor Frame Size	56	56	56	56
<b>Filter - Type</b>	Disposable	Disposable	Disposable	Disposable
Furnished	Yes	Yes	Yes	Yes
(NO.) Size Recommended in. [mm x mm x mm]	(6)2x18x18 [51x457x457]	(6)2x18x18 [51x457x457]	(6)2x18x18 [51x457x457]	(6)2x18x18 [51x457x457]
<b>Refrigerant Charge Oz. [g]</b>	117.6 [3334]	117.6 [3334]	117.6 [3334]	117.6 [3334]
<b>Weights</b>				
Net Weight lbs. [kg]	882 [401]	882 [401]	890 [404]	882 [401]
Ship Weight lbs. [kg]	919 [417]	919 [417]	927 [420]	919 [417]

See Page 17 for Notes.

[ ] Designates Metric Conversions

## NOM. SIZES 7.5, 10, & 12.5 TON [26.4, 35.2 & 44.0 kW] ASHRAE 90.1-2010 COMPLIANT MODELS

Model RLKL- Series	B090DM	B090DN	B090YL	B090YM
<b>Cooling Performance<sup>1</sup></b>				
Gross Cooling Capacity Btu [kW]	87,000 [25.49]	87,000 [25.49]	87,000 [25.49]	87,000 [25.49]
EER/SEER <sup>2</sup>	11.2/NA	11.2/NA	11.2/NA	11.2/NA
Nominal CFM/AHRI Rated CFM [L/s]	2800/2925 [1321/1380]	2800/2925 [1321/1380]	2800/2925 [1321/1380]	2800/2925 [1321/1380]
AHRI Net Cooling Capacity Btu [kW]	84,000 [24.61]	84,000 [24.61]	84,000 [24.61]	84,000 [24.61]
Net Sensible Capacity Btu [kW]	64,800 [18.99]	64,800 [18.99]	64,800 [18.99]	64,800 [18.99]
Net Latent Capacity Btu [kW]	19,200 [5.63]	19,200 [5.63]	19,200 [5.63]	19,200 [5.63]
IEER <sup>3</sup>	12.1	12.1	12.1	12.1
Net System Power kW	7.5	7.5	7.5	7.5
<b>Compressor</b>				
No./Type	1/Scroll	1/Scroll	1/Scroll	1/Scroll
<b>Outdoor Sound Rating (dB)<sup>4</sup></b>				
	88	88	88	88
<b>Outdoor Coil - Fin Type</b>				
Tube Type	MicroChannel	MicroChannel	MicroChannel	MicroChannel
MicroChannel Depth in. [mm]	1 [25.4]	1 [25.4]	1 [25.4]	1 [25.4]
Face Area sq. ft. [sq. m]	13.5 [1.25]	13.5 [1.25]	13.5 [1.25]	13.5 [1.25]
Rows / FPI [FPcm]	1 / 23 [9]	1 / 23 [9]	1 / 23 [9]	1 / 23 [9]
<b>Indoor Coil - Fin Type</b>				
Tube Type	Rifled	Rifled	Rifled	Rifled
Tube Size in. [mm]	0.375 [9.5]	0.375 [9.5]	0.375 [9.5]	0.375 [9.5]
Face Area sq. ft. [sq. m]	13.5 [1.25]	13.5 [1.25]	13.5 [1.25]	13.5 [1.25]
Rows / FPI [FPcm]	2 / 18 [7]	2 / 18 [7]	2 / 18 [7]	2 / 18 [7]
Refrigerant Control	Orifices	Orifices	Orifices	Orifices
Drain Connection No./Size in. [mm]	1/1 [25.4]	1/1 [25.4]	1/1 [25.4]	1/1 [25.4]
<b>Outdoor Fan - Type</b>				
No. Used/Diameter in. [mm]	1/24 [609.6]	1/24 [609.6]	1/24 [609.6]	1/24 [609.6]
Drive Type/No. Speeds	Direct/1	Direct/1	Direct/1	Direct/1
CFM [L/s]	4500 [2124]	4500 [2124]	4500 [2124]	4500 [2124]
No. Motors/HP	1 at 1/2 HP	1 at 1/2 HP	1 at 1/2 HP	1 at 1/2 HP
Motor RPM	1075	1075	1075	1075
<b>Indoor Fan - Type</b>				
No. Used/Diameter in. [mm]	1/15x15 [381x381]	1/15x15 [381x381]	1/15x15 [381x381]	1/15x15 [381x381]
Drive Type/No. Speeds	Belt/Variable	Belt/Variable	Belt/Variable	Belt/Variable
No. Motors	1	1	1	1
Motor HP	2	3	2	2
Motor RPM	1725	1725	1725	1725
Motor Frame Size	56	56	56	56
<b>Filter - Type</b>				
Furnished	Yes	Yes	Yes	Yes
(NO.) Size Recommended in. [mm x mm x mm]	(6)2x18x18 [51x457x457]	(6)2x18x18 [51x457x457]	(6)2x18x18 [51x457x457]	(6)2x18x18 [51x457x457]
<b>Refrigerant Charge Oz. [g]</b>				
	117.6 [3334]	117.6 [3334]	117.6 [3334]	117.6 [3334]
<b>Weights</b>				
Net Weight lbs. [kg]	882 [401]	890 [404]	882 [401]	882 [401]
Ship Weight lbs. [kg]	919 [417]	927 [420]	919 [420]	919 [420]

See Page 17 for Notes.

[ ] Designates Metric Conversions

## NOM. SIZES 7.5, 10, & 12.5 TON [26.4, 35.2 & 44.0 kW] ASHRAE 90.1-2010 COMPLIANT MODELS

Model RLKL- Series	B090YN	B120CL	B120CM	B120DL
<b>Cooling Performance<sup>1</sup></b>				<b>CONTINUED</b> →
Gross Cooling Capacity Btu [kW]	87,000 [25.49]	123,000 [36.04]	123,000 [36.04]	123,000 [36.04]
EER/SEER <sup>2</sup>	11.2/NA	11.2/NA	11.2/NA	11.2/NA
Nominal CFM/AHRI Rated CFM [L/s]	2800/2925 [1321/1380]	4000/3600 [1888/1699]	4000/3600 [1888/1699]	4000/3600 [1888/1699]
AHRI Net Cooling Capacity Btu [kW]	84,000 [24.61]	119,000 [34.87]	119,000 [34.87]	119,000 [34.87]
Net Sensible Capacity Btu [kW]	64,800 [18.99]	87,200 [25.55]	87,200 [25.55]	87,200 [25.55]
Net Latent Capacity Btu [kW]	19,200 [5.63]	31,800 [9.32]	31,800 [9.32]	31,800 [9.32]
IEER <sup>3</sup>	12.1	12.2	12.2	12.2
Net System Power kW	7.5	10.62	10.62	10.62
<b>Compressor</b>				
No./Type	1/Scroll	1/Scroll	1/Scroll	1/Scroll
<b>Outdoor Sound Rating (dB)<sup>4</sup></b>	88	88	88	88
<b>Outdoor Coil - Fin Type</b>	Louvered	Louvered	Louvered	Louvered
Tube Type	MicroChannel	MicroChannel	MicroChannel	MicroChannel
MicroChannel Depth in. [mm]	1 [25.4]	1 [25.4]	1 [25.4]	1 [25.4]
Face Area sq. ft. [sq. m]	13.5 [1.25]	27 [2.51]	27 [2.51]	27 [2.51]
Rows / FPI [FPcm]	1 / 23 [9]	1 / 23 [9]	1 / 23 [9]	1 / 23 [9]
<b>Indoor Coil - Fin Type</b>	Louvered	Louvered	Louvered	Louvered
Tube Type	Rifled	Rifled	Rifled	Rifled
Tube Size in. [mm]	0.375 [9.5]	0.375 [9.5]	0.375 [9.5]	0.375 [9.5]
Face Area sq. ft. [sq. m]	13.5 [1.25]	13.5 [1.25]	13.5 [1.25]	13.5 [1.25]
Rows / FPI [FPcm]	2 / 18 [7]	2 / 22 [9]	2 / 22 [9]	2 / 22 [9]
Refrigerant Control	Orifices	Orifices	Orifices	Orifices
Drain Connection No./Size in. [mm]	1/1 [25.4]	1/1 [25.4]	1/1 [25.4]	1/1 [25.4]
<b>Outdoor Fan - Type</b>	Propeller	Propeller	Propeller	Propeller
No. Used/Diameter in. [mm]	1/24 [609.6]	2/24 [609.6]	2/24 [609.6]	2/24 [609.6]
Drive Type/No. Speeds	Direct/1	Direct/1	Direct/1	Direct/1
CFM [L/s]	4500 [2124]	8400 [3964]	8400 [3964]	8400 [3964]
No. Motors/HP	1 at 1/2 HP	2 at 1/3 HP	2 at 1/3 HP	2 at 1/3 HP
Motor RPM	1075	1075	1075	1075
<b>Indoor Fan - Type</b>	FC Centrifugal	FC Centrifugal	FC Centrifugal	FC Centrifugal
No. Used/Diameter in. [mm]	1/15x15 [381x381]	1/15x15 [381x381]	1/15x15 [381x381]	1/15x15 [381x381]
Drive Type/No. Speeds	Belt/Variable	Belt/Variable	Belt/Variable	Belt/Variable
No. Motors	1	1	1	1
Motor HP	3	2	3	2
Motor RPM	1725	1725	1725	1725
Motor Frame Size	56	56	56	56
<b>Filter - Type</b>	Disposable	Disposable	Disposable	Disposable
Furnished	Yes	Yes	Yes	Yes
(NO.) Size Recommended in. [mm x mm x mm]	(6)2x18x18 [51x457x457]	(6)2x18x18 [51x457x457]	(6)2x18x18 [51x457x457]	(6)2x18x18 [51x457x457]
<b>Refrigerant Charge Oz. [g]</b>	117.6 [3334]	204.8 [5806]	204.8 [5806]	204.8 [5806]
<b>Weights</b>				
Net Weight lbs. [kg]	890 [404]	984 [446]	992 [450]	984 [446]
Ship Weight lbs. [kg]	927 [420]	1021 [463]	1029 [467]	1021 [463]

See Page 17 for Notes.

[ ] Designates Metric Conversions

## NOM. SIZES 7.5, 10, & 12.5 TON [26.4, 35.2 & 44.0 kW] ASHRAE 90.1-2010 COMPLIANT MODELS

Model RLKL- Series	B120DM	B120DL	B120YM	B151CL
<b>Cooling Performance<sup>1</sup></b>				<b>CONTINUED</b> →
Gross Cooling Capacity Btu [kW]	123,000 [36.04]	123,000 [36.04]	123,000 [36.04]	146,000 [42.78]
EER/SEER <sup>2</sup>	11.2/NA	11.2/NA	11.2/NA	11/NA
Nominal CFM/AHRI Rated CFM [L/s]	4000/3600 [1888/1699]	4000/3600 [1888/1699]	4000/3600 [1888/1699]	5000/4225 [2360/1994]
AHRI Net Cooling Capacity Btu [kW]	119,000 [34.87]	119,000 [34.87]	119,000 [34.87]	140,000 [41.02]
Net Sensible Capacity Btu [kW]	87,200 [25.55]	87,200 [25.55]	87,200 [25.55]	99,500 [29.15]
Net Latent Capacity Btu [kW]	31,800 [9.32]	31,800 [9.32]	31,800 [9.32]	40,500 [11.87]
IEER <sup>3</sup>	12.2	12.2	12.2	10.8
Net System Power [kW]	10.62	10.62	10.62	12.73
<b>Compressor</b>				
No./Type	1/Scroll	1/Scroll	1/Scroll	2/Scroll
<b>Outdoor Sound Rating (dB)<sup>4</sup></b>	88	88	88	88
<b>Outdoor Coil—Fin Type</b>	Louvered	Louvered	Louvered	Louvered
Tube Type	MicroChannel	MicroChannel	MicroChannel	MicroChannel
MicroChannel Depth In. [mm]	1 [25.4]	1 [25.4]	1 [25.4]	1 [25.4]
Face Area sq. ft. [sq. m]	27 [2.51]	27 [2.51]	27 [2.51]	27 [2.51]
Rows / FPI [FPcm]	1 / 23 [9]	1 / 23 [9]	1 / 23 [9]	2 / 23 [9]
<b>Indoor Coil—Fin Type</b>	Louvered	Louvered	Louvered	Louvered
Tube Type	Rifled	Rifled	Rifled	Rifled
Tube Size in. [mm]	0.375 [9.5]	0.375 [9.5]	0.375 [9.5]	0.375 [9.5]
Face Area sq. ft. [sq. m]	13.5 [1.25]	13.5 [1.25]	13.5 [1.25]	13.5 [1.25]
Rows / FPI [FPcm]	2 / 22 [9]	2 / 22 [9]	2 / 22 [9]	4 / 15 [6]
Refrigerant Control	Orifices	Orifices	Orifices	TX Valves
Drain Connection No./Size in. [mm]	1/1 [25.4]	1/1 [25.4]	1/1 [25.4]	1/1 [25.4]
<b>Outdoor Fan—Type</b>	Propeller	Propeller	Propeller	Propeller
No. Used/Diameter in. [mm]	2/24 [609.6]	2/24 [609.6]	2/24 [609.6]	2/24 [609.6]
Drive Type/No. Speeds	Direct/1	Direct/1	Direct/1	Direct/1
CFM [L/s]	8400 [3964]	8400 [3964]	8400 [3964]	8000 [3775]
No. Motors/HP	2 at 1/3 HP	2 at 1/3 HP	2 at 1/3 HP	2 at 1/2 HP
Motor RPM	1075	1075	1075	1075
<b>Indoor Fan—Type</b>	FC Centrifugal	FC Centrifugal	FC Centrifugal	FC Centrifugal
No. Used/Diameter in. [mm]	1/15x15 [381x381]	1/15x15 [381x381]	1/15x15 [381x381]	1/15x15 [381x381]
Drive Type/No. Speeds	Belt/Variable	Belt/Variable	Belt/Variable	Belt (Adjustable)/Single
No. Motors	1	1	1	1
Motor HP	3	2	3	3
Motor RPM	1725	1725	1725	1725
Motor Frame Size	56	56	56	56
<b>Filter—Type</b>	Disposable	Disposable	Disposable	Disposable
Furnished	Yes	Yes	Yes	Yes
(NO.) Size Recommended in. [mm x mm x mm]	(6)2x18x18 [51x457x457]	(6)2x18x18 [51x457x457]	(6)2x18x18 [51x457x457]	(6)2x18x18 [51x457x457]
<b>Refrigerant Charge Oz. [g]</b>	204.8 [5806]	204.8 [5806]	204.8 [5806]	147.2/152 [4173/4309]
<b>Weights</b>				
Net Weight lbs. [kg]	992 [450]	984 [446]	992 [450]	1230 [558]
Ship Weight lbs. [kg]	1029 [467]	1021 [463]	1029 [467]	1267 [575]

See Page 17 for Notes.

[ ] Designates Metric Conversions

## NOM. SIZES 7.5, 10, & 12.5 TON [26.4, 35.2 & 44.0 kW] ASHRAE 90.1-2010 COMPLIANT MODELS

Model RLKL- Series	B151CM	B151DL	B151DM	B151YL
<b>Cooling Performance<sup>1</sup></b>				<b>CONTINUED</b> 
Gross Cooling Capacity Btu [kW]	146,000 [42.78]	146,000 [42.78]	146,000 [42.78]	146,000 [42.78]
EER/SEER <sup>2</sup>	11/NA	11/NA	11/NA	11/NA
Nominal CFM/AHRI Rated CFM [L/s]	5000/4225 [2360/1994]	5000/4225 [2360/1994]	5000/4225 [2360/1994]	5000/4225 [2360/1994]
AHRI Net Cooling Capacity Btu [kW]	140,000 [41.02]	140,000 [41.02]	140,000 [41.02]	140,000 [41.02]
Net Sensible Capacity Btu [kW]	99,500 [29.15]	99,500 [29.15]	99,500 [29.15]	99,500 [29.15]
Net Latent Capacity Btu [kW]	40,500 [11.87]	40,500 [11.87]	40,500 [11.87]	40,500 [11.87]
IEER <sup>3</sup>	10.8	10.8	10.8	10.8
Net System Power [kW]	12.73	12.73	12.73	12.73
<b>Compressor</b>				
No./Type	2/Scroll	2/Scroll	2/Scroll	2/Scroll
<b>Outdoor Sound Rating (dB)<sup>4</sup></b>	88	88	88	88
<b>Outdoor Coil—Fin Type</b>	Louvered	Louvered	Louvered	Louvered
Tube Type	MicroChannel	MicroChannel	MicroChannel	MicroChannel
MicroChannel Depth In. [mm]	1 [25.4]	1 [25.4]	1 [25.4]	1 [25.4]
Face Area sq. ft. [sq. m]	27 [2.51]	27 [2.51]	27 [2.51]	27 [2.51]
Rows / FPI [FPcm]	2 / 23 [9]	2 / 23 [9]	2 / 23 [9]	2 / 23 [9]
<b>Indoor Coil—Fin Type</b>	Louvered	Louvered	Louvered	Louvered
Tube Type	Rifled	Rifled	Rifled	Rifled
Tube Size in. [mm]	0.375 [9.5]	0.375 [9.5]	0.375 [9.5]	0.375 [9.5]
Face Area sq. ft. [sq. m]	13.5 [1.25]	13.5 [1.25]	13.5 [1.25]	13.5 [1.25]
Rows / FPI [FPcm]	4 / 15 [6]	4 / 15 [6]	4 / 15 [6]	4 / 15 [6]
Refrigerant Control	TX Valves	TX Valves	TX Valves	TX Valves
Drain Connection No./Size in. [mm]	1/1 [25.4]	1/1 [25.4]	1/1 [25.4]	1/1 [25.4]
<b>Outdoor Fan—Type</b>	Propeller	Propeller	Propeller	Propeller
No. Used/Diameter in. [mm]	2/24 [609.6]	2/24 [609.6]	2/24 [609.6]	2/24 [609.6]
Drive Type/No. Speeds	Direct/1	Direct/1	Direct/1	Direct/1
CFM [L/s]	8000 [3775]	8000 [3775]	8000 [3775]	8000 [3775]
No. Motors/HP	2 at 1/2 HP	2 at 1/2 HP	2 at 1/2 HP	2 at 1/2 HP
Motor RPM	1075	1075	1075	1075
<b>Indoor Fan—Type</b>	FC Centrifugal	FC Centrifugal	FC Centrifugal	FC Centrifugal
No. Used/Diameter in. [mm]	1/15x15 [381x381]	1/15x15 [381x381]	1/15x15 [381x381]	1/15x15 [381x381]
Drive Type/No. Speeds	Belt (Adjustable)/Single	Belt (Adjustable)/Single	Belt (Adjustable)/Single	Belt (Adjustable)/Single
No. Motors	1	1	1	1
Motor HP	5	3	5	3
Motor RPM	1725	1725	1725	1725
Motor Frame Size	184	56	184	56
<b>Filter—Type</b>	Disposable	Disposable	Disposable	Disposable
Furnished	Yes	Yes	Yes	Yes
(NO.) Size Recommended in. [mm x mm x mm]	(6)2x18x18 [51x457x457]	(6)2x18x18 [51x457x457]	(6)2x18x18 [51x457x457]	(6)2x18x18 [51x457x457]
<b>Refrigerant Charge Oz. [g]</b>	147.2/152 [4173/4309]	147.2/152 [4173/4309]	147.2/152 [4173/4309]	147.2/152 [4173/4309]
<b>Weights</b>				
Net Weight lbs. [kg]	1238 [562]	1230 [558]	1238 [562]	1230 [558]
Ship Weight lbs. [kg]	1275 [578]	1267 [575]	1275 [578]	1267 [575]

See Page 17 for Notes.

[ ] Designates Metric Conversions

## NOM. SIZES 7.5, 10, & 12.5 TON [26.4, 35.2 & 44.0 kW] ASHRAE 90.1-2010 COMPLIANT MODELS

Model RLKL- Series	B151YM
<b>Cooling Performance<sup>1</sup></b>	
Gross Cooling Capacity Btu [kW]	146,000 [42.78]
EER/SEER <sup>2</sup>	11/NA
Nominal CFM/AHRI Rated CFM [L/s]	5000/4225 [2360/1994]
AHRI Net Cooling Capacity Btu [kW]	140,000 [41.02]
Net Sensible Capacity Btu [kW]	99,500 [29.15]
Net Latent Capacity Btu [kW]	40,500 [11.87]
IEER <sup>3</sup>	10.8
Net System Power [kW]	12.73
<b>Compressor</b>	
No./Type	2/Scroll
<b>Outdoor Sound Rating (dB)<sup>4</sup></b>	
88	
<b>Outdoor Coil—Fin Type</b>	
Louvered	
Tube Type	MicroChannel
MicroChannel Depth In. [mm]	1 [25.4]
Face Area sq. ft. [sq. m]	27 [2.51]
Rows / FPI [FPcm]	2 / 23 [9]
<b>Indoor Coil—Fin Type</b>	
Louvered	
Tube Type	Rifled
Tube Size in. [mm]	0.375 [9.5]
Face Area sq. ft. [sq. m]	13.5 [1.25]
Rows / FPI [FPcm]	4 / 15 [6]
Refrigerant Control	TX Valves
Drain Connection No./Size in. [mm]	1/1 [25.4]
<b>Outdoor Fan—Type</b>	
Propeller	
No. Used/Diameter in. [mm]	2/24 [609.6]
Drive Type/No. Speeds	Direct/1
CFM [L/s]	8000 [3775]
No. Motors/HP	2 at 1/2 HP
Motor RPM	1075
<b>Indoor Fan—Type</b>	
FC Centrifugal	
No. Used/Diameter in. [mm]	1/15x15 [381x381]
Drive Type/No. Speeds	Belt (Adjustable)/Single
No. Motors	1
Motor HP	5
Motor RPM	1725
Motor Frame Size	184
<b>Filter—Type</b>	
Disposable	
Furnished	Yes
(NO.) Size Recommended in. [mm x mm x mm]	(6)2x18x18 [51x457x457]
<b>Refrigerant Charge Oz. [g]</b>	
147.2/152 [4173/4309]	
<b>Weights</b>	
Net Weight lbs. [kg]	1238 [562]
Ship Weight lbs. [kg]	1275 [578]

See Page 17 for Notes.

[ ] Designates Metric Conversions



## NOTES:

1. Cooling Performance is rated at 95° F ambient, 80° F entering dry bulb, 67° F entering wet bulb. Gross capacity does not include the effect of fan motor heat. AHRI capacity is net and includes the effect of fan motor heat. Units are suitable for operation to  $\pm 20\%$  of nominal cfm. Units are certified in accordance with the Unitary Air Conditioner Equipment certification program, which is based on AHRI Standard 340/360.
2. EER and/or SEER are rated at AHRI conditions and in accordance with DOE test procedures.
3. IEER is rated in accordance with AHRI Standard 340/360. Units are rated at 80° F ambient, 80° F entering dry bulb, and 67° F entering wet bulb at AHRI rated cfm.
4. Outdoor Sound Rating shown is tested in accordance with AHRI Standard 270.



## GROSS SYSTEMS PERFORMANCE DATA—B090

		ENTERING INDOOR AIR @ 80°F [26.7°C] dbE ①									
wbE		71°F [21.7°C]			67°F [19.4°C]			63°F [17.2°C]			
CFM [L/s]		3600 [1699]	2925 [1380]	2400 [1133]	3600 [1699]	2925 [1380]	2400 [1133]	3600 [1699]	2925 [1380]	2400 [1133]	
DR ①		.05	.09	.11	.05	.09	.11	.05	.09	.11	
OUTDOOR DRY BULB TEMPERATURE °F [°C]	75 [23.9]	Total BTUH [kW] Sens BTUH [kW] Power	106.3 [31.2] 73.3 [21.5] 5.7	102.1 [29.9] 62.0 [18.2] 5.5	98.7 [28.9] 53.7 [15.7] 5.5	100.6 [29.5] 84.3 [24.7] 5.6	96.5 [28.3] 72.0 [21.1] 5.4	93.4 [27.4] 63.1 [18.5] 5.4	97.3 [28.5] 94.8 [27.8] 5.4	93.4 [27.4] 81.7 [24.0] 5.3	90.4 [26.5] 72.1 [21.1] 5.2
	80 [26.7]	Total BTUH [kW] Sens BTUH [kW] Power	104.4 [30.6] 72.6 [21.3] 6.0	100.2 [29.4] 61.3 [18.0] 5.8	96.9 [28.4] 53.1 [15.6] 5.7	98.6 [28.9] 83.3 [24.4] 5.8	94.6 [27.7] 71.2 [20.9] 5.7	91.6 [26.8] 62.5 [18.3] 5.6	95.3 [27.9] 93.9 [27.5] 5.7	91.5 [26.8] 81.0 [23.7] 5.6	88.5 [25.9] 71.5 [21.0] 5.5
	85 [29.4]	Total BTUH [kW] Sens BTUH [kW] Power	102.0 [29.9] 71.3 [20.9] 6.3	97.9 [28.7] 60.3 [17.7] 6.1	94.7 [27.8] 52.3 [15.3] 6.0	96.3 [28.2] 82.2 [24.1] 6.2	92.4 [27.1] 70.3 [20.6] 6.0	89.4 [26.2] 61.7 [18.1] 5.9	93.0 [27.3] 92.8 [27.2] 6.0	89.2 [26.1] 80.0 [23.5] 5.9	86.3 [25.3] 70.6 [20.7] 5.8
	90 [32.2]	Total BTUH [kW] Sens BTUH [kW] Power	99.3 [29.1] 69.9 [20.5] 6.6	95.3 [27.9] 59.1 [17.3] 6.5	92.2 [27.0] 51.3 [15.0] 6.4	93.5 [27.4] 80.6 [23.6] 6.5	89.8 [26.3] 69.1 [20.3] 6.3	86.8 [25.4] 60.6 [17.8] 6.2	90.3 [26.5] 90.3 [26.5] 6.4	86.6 [25.4] 78.7 [23.1] 6.2	83.8 [24.6] 69.5 [20.4] 6.1
	95 [35]	Total BTUH [kW] Sens BTUH [kW] Power	96.2 [28.2] 68.1 [20.0] 6.9	92.3 [27.1] 57.6 [16.9] 6.8	89.3 [26.2] 50.0 [14.7] 6.7	90.5 [26.5] 79.0 [23.2] 6.8	86.8 [25.4] 67.6 [19.8] 6.7	84.0 [24.6] 59.4 [17.4] 6.6	87.2 [25.6] 87.2 [25.6] 6.7	83.7 [24.5] 77.3 [22.7] 6.6	80.9 [23.7] 68.3 [20.0] 6.5
	100 [37.8]	Total BTUH [kW] Sens BTUH [kW] Power	92.7 [27.2] 66.0 [19.4] 7.3	89.0 [26.1] 55.9 [16.4] 7.1	86.1 [25.2] 48.6 [14.3] 7.0	87.0 [25.5] 76.9 [22.5] 7.2	83.5 [24.5] 65.9 [19.3] 7.0	80.8 [23.7] 57.9 [17.0] 6.9	83.7 [24.5] 83.7 [24.5] 7.1	80.3 [23.5] 75.5 [22.1] 6.9	77.7 [22.8] 66.8 [19.6] 6.8
	105 [40.6]	Total BTUH [kW] Sens BTUH [kW] Power	88.9 [26.1] 63.7 [18.7] 7.6	85.3 [25.0] 53.9 [15.8] 7.5	82.5 [24.2] 46.8 [13.7] 7.4	83.2 [24.4] 74.5 [21.8] 7.5	79.8 [23.4] 63.9 [18.7] 7.4	77.2 [22.6] 56.2 [16.5] 7.3	79.9 [23.4] 79.9 [23.4] 7.4	76.7 [22.5] 73.6 [21.6] 7.3	74.2 [21.7] 65.1 [19.1] 7.2
	110 [43.3]	Total BTUH [kW] Sens BTUH [kW] Power	84.7 [24.8] 61.0 [17.9] 8.0	81.3 [23.8] 51.7 [15.2] 7.9	78.7 [23.1] 45.0 [13.2] 7.7	79.0 [23.2] 71.9 [21.1] 7.9	75.8 [22.2] 61.7 [18.1] 7.8	73.3 [21.5] 54.2 [15.9] 7.6	75.7 [22.2] 75.7 [22.2] 7.8	72.6 [21.3] 71.3 [20.9] 7.7	70.3 [20.6] 63.2 [18.5] 7.5
	115 [46.1]	Total BTUH [kW] Sens BTUH [kW] Power	80.1 [23.5] 58.0 [17.0] 8.4	76.9 [22.5] 49.2 [14.4] 8.3	74.4 [21.8] 42.8 [12.6] 8.1	74.4 [21.8] 68.9 [20.2] 8.3	71.4 [20.9] 59.2 [17.4] 8.2	69.1 [20.3] 52.1 [15.3] 8.0	71.1 [20.8] 71.1 [20.8] 8.2	68.3 [20.0] 68.3 [20.0] 8.1	66.0 [19.3] 61.1 [17.9] 7.9

## GROSS SYSTEMS PERFORMANCE DATA—B120

		ENTERING INDOOR AIR @ 80°F [26.7°C] dbE ①									
wbE		71°F [21.7°C]			67°F [19.4°C]			63°F [17.2°C]			
CFM [L/s]		4800 [2265]	3600 [1699]	3200 [1510]	4800 [2265]	3600 [1699]	3200 [1510]	4800 [2265]	3600 [1699]	3200 [1510]	
DR ①		.0	.04	.07	.0	.04	.07	.0	.04	.07	
OUTDOOR DRY BULB TEMPERATURE °F [°C]	75 [23.9]	Total BTUH [kW] Sens BTUH [kW] Power	153.4 [45.0] 105.0 [30.8] 7.8	144.6 [42.4] 82.1 [24.1] 7.6	141.7 [41.5] 75.1 [22.0] 7.5	146.5 [42.9] 123.1 [36.1] 7.6	138.2 [40.5] 98.2 [28.8] 7.4	135.4 [39.7] 90.5 [26.5] 7.3	141.4 [41.4] 140.1 [41.1] 7.4	133.3 [39.1] 113.1 [33.2] 7.2	130.6 [38.3] 104.7 [30.7] 7.2
	80 [26.7]	Total BTUH [kW] Sens BTUH [kW] Power	150.0 [44.0] 103.2 [30.3] 8.2	141.5 [41.5] 80.8 [23.7] 8.0	138.6 [40.6] 73.9 [21.7] 7.9	143.2 [42.0] 121.3 [35.6] 8.0	135.0 [39.6] 96.8 [28.4] 7.8	132.3 [38.8] 89.2 [26.2] 7.7	138.0 [40.4] 138.0 [40.5] 7.8	130.2 [38.2] 111.8 [32.8] 7.6	127.5 [37.4] 103.4 [30.3] 7.5
	85 [29.4]	Total BTUH [kW] Sens BTUH [kW] Power	146.3 [42.9] 101.1 [29.6] 8.6	138.0 [40.4] 79.2 [23.2] 8.3	135.2 [39.6] 72.4 [21.2] 8.3	139.5 [40.9] 119.3 [35.0] 8.4	131.5 [38.5] 95.2 [27.9] 8.2	128.8 [37.7] 87.7 [25.7] 8.1	134.3 [39.4] 134.3 [39.4] 8.2	126.6 [37.1] 110.2 [32.3] 8.0	124.1 [36.4] 102.1 [29.9] 7.9
	90 [32.2]	Total BTUH [kW] Sens BTUH [kW] Power	142.2 [41.7] 98.9 [29.0] 9.0	134.1 [39.3] 77.5 [22.7] 8.7	131.4 [38.5] 70.9 [20.8] 8.7	135.4 [39.7] 117.1 [34.3] 8.8	127.6 [37.4] 93.5 [27.4] 8.6	125.0 [36.6] 86.2 [25.3] 8.5	130.2 [38.2] 130.2 [38.2] 8.6	122.8 [36.0] 108.5 [31.8] 8.4	120.3 [35.3] 100.5 [29.5] 8.3
	95 [35]	Total BTUH [kW] Sens BTUH [kW] Power	137.7 [40.4] 96.4 [28.3] 9.4	129.8 [38.0] 75.5 [22.1] 9.2	127.2 [37.3] 69.1 [20.3] 9.1	130.9 [38.4] 114.5 [33.6] 9.2	123.4 [36.2] 91.6 [26.9] 9.0	120.9 [35.4] 84.5 [24.8] 8.9	125.7 [36.8] 125.7 [36.8] 9.0	118.5 [34.7] 106.6 [31.3] 8.8	116.1 [34.0] 98.8 [29.0] 8.7
	100 [37.8]	Total BTUH [kW] Sens BTUH [kW] Power	132.8 [38.9] 93.6 [27.4] 9.9	125.2 [36.7] 73.4 [21.5] 9.6	122.7 [36.0] 67.2 [19.7] 9.5	126.0 [36.9] 111.7 [32.7] 9.7	118.8 [34.8] 89.5 [26.2] 9.4	116.4 [34.1] 82.6 [24.2] 9.3	120.8 [35.4] 120.8 [35.4] 9.5	113.9 [33.4] 104.5 [30.6] 9.2	111.6 [32.7] 96.9 [28.4] 9.1
	105 [40.6]	Total BTUH [kW] Sens BTUH [kW] Power	127.6 [37.4] 90.7 [26.6] 10.6	120.3 [35.3] 71.2 [20.9] 10.1	117.9 [34.6] 65.2 [19.1] 10.0	120.7 [35.4] 108.7 [31.9] 10.2	113.8 [33.4] 87.2 [25.6] 9.9	111.5 [32.7] 80.5 [23.6] 9.8	115.6 [33.9] 115.6 [33.9] 10.0	109.0 [31.9] 102.2 [30.0] 9.7	106.8 [31.3] 94.8 [27.8] 9.6
	110 [43.3]	Total BTUH [kW] Sens BTUH [kW] Power	121.9 [35.7] 87.4 [25.6] 10.9	115.0 [33.7] 68.7 [20.1] 10.6	112.6 [33.0] 62.9 [18.4] 10.5	115.1 [33.7] 105.5 [30.9] 10.7	108.5 [31.8] 84.7 [24.8] 10.4	106.3 [31.2] 78.2 [22.9] 10.3	109.9 [32.2] 109.9 [32.2] 10.5	103.6 [30.4] 99.7 [29.2] 10.2	101.5 [29.7] 92.5 [27.1] 10.1
	115 [46.1]	Total BTUH [kW] Sens BTUH [kW] Power	115.9 [34.0] 84.0 [24.6] 11.4	109.3 [32.0] 66.1 [19.4] 11.1	107.1 [31.4] 60.6 [17.8] 11.0	109.0 [31.9] 102.0 [29.9] 11.2	102.8 [30.1] 82.1 [24.1] 10.9	100.7 [29.5] 75.9 [22.3] 10.8	103.9 [30.5] 103.9 [30.5] 11.0	98.0 [28.7] 97.1 [28.5] 10.7	96.0 [28.1] 90.2 [26.4] 10.6

DR —Depression ratio  
dbE —Entering air dry bulb  
wbE —Entering air wet bulb

Total —Total capacity x 1000 BTUH  
Sens —Sensible capacity x 1000 BTUH  
Power —kW input

NOTES: ① When the entering air dry bulb is other than 80°F [27°C], adjust the sensible capacity from the table by adding [1.10 x CFM x (1 - DR) x (dbE - 80)].

[ ] Designates Metric Conversions





# GROSS SYSTEMS PERFORMANCE DATA—B151

ENTERING INDOOR AIR @ 80°F [26.7°C] dbE ①											
wbE		71°F [21.7°C]			67°F [19.4°C]			63°F [17.2°C]			
CFM [L/s]		5070 [2393]	4225 [1994]	3380 [1595]	5070 [2393]	4225 [1994]	3380 [1595]	5070 [2393]	4225 [1994]	3380 [1595]	
DR ①		0.11	0.08	0.05	0.11	0.08	0.05	0.11	0.08	0.05	
OUTDOOR DRY BULB TEMPERATURE °F [°C]	75 [23.9]	Total BTUH [kW] Sens BTUH [kW] Power	180.7 [52.9] 98.6 [28.9] 9.2	174.3 [51.1] 90.2 [26.4] 9.1	168 [49.2] 81.8 [24.0] 8.9	171.0 [50.1] 119.8 [35.1] 9	165 [48.3] 109.6 [32.1] 8.8	159 [46.6] 99.4 [29.1] 8.7	163 [47.8] 137.4 [40.3] 8.8	157.3 [46.1] 125.7 [36.8] 8.6	151.6 [44.4] 114 [33.4] 8.5
	80 [26.7]	Total BTUH [kW] Sens BTUH [kW] Power	176.1 [51.6] 98.5 [28.9] 9.7	169.9 [49.8] 90.1 [26.4] 9.5	163.7 [48.0] 81.7 [23.9] 9.4	166.4 [48.8] 119.7 [35.1] 9.5	160.6 [47.1] 109.5 [32.1] 9.3	154.7 [45.3] 99.3 [29.1] 9.2	158.4 [46.4] 137.3 [40.2] 9.3	152.9 [44.8] 125.6 [36.8] 9.1	147.3 [43.2] 113.9 [33.4] 8.9
	85 [29.4]	Total BTUH [kW] Sens BTUH [kW] Power	171.3 [50.2] 97.8 [28.7] 10.2	165.3 [48.4] 89.4 [26.2] 10	159.3 [46.7] 81.1 [23.8] 9.9	161.6 [47.4] 119 [34.9] 10	156 [45.7] 108.8 [31.9] 9.8	150.3 [44.0] 98.7 [28.9] 9.6	153.6 [45.0] 136.6 [40.0] 9.8	148.3 [43.4] 124.9 [36.6] 9.6	142.9 [41.9] 113.3 [33.2] 9.4
	90 [32.2]	Total BTUH [kW] Sens BTUH [kW] Power	166.4 [48.8] 96.4 [28.2] 10.8	160.5 [47.0] 88.2 [25.8] 10.6	154.7 [45.3] 79.9 [23.4] 10.4	156.7 [45.9] 117.6 [34.5] 10.5	151.2 [44.3] 107.6 [31.5] 10.4	145.7 [42.7] 97.5 [28.6] 10.2	148.7 [43.6] 135.2 [39.6] 10.3	143.5 [42.0] 123.7 [36.2] 10.1	138.2 [40.5] 112.1 [32.9] 9.9
	95 [35]	Total BTUH [kW] Sens BTUH [kW] Power	161.2 [47.2] 94.4 [27.7] 11.3	155.6 [45.6] 86.3 [25.3] 11.1	149.9 [43.9] 78.3 [22.9] 10.9	151.5 [44.4] 115.6 [33.9] 11.1	146.2 [42.8] 105.7 [31.0] 10.9	140.9 [41.3] 95.8 [28.1] 10.7	143.5 [42.1] 133.2 [39.0] 10.9	138.5 [40.6] 121.8 [35.7] 10.7	133.5 [39.1] 110.4 [32.4] 10.5
	100 [37.8]	Total BTUH [kW] Sens BTUH [kW] Power	155.9 [45.7] 91.7 [26.9] 11.9	150.4 [44.1] 83.9 [24.6] 11.7	144.9 [42.5] 76 [22.3] 11.5	146.2 [42.8] 112.9 [33.1] 11.7	141 [41.3] 103.3 [30.3] 11.5	135.9 [39.8] 93.6 [27.4] 11.3	138.2 [40.5] 130.5 [38.2] 11.5	133.3 [39.1] 119.4 [35] 11.3	128.5 [37.7] 108.2 [31.7] 11.1
	105 [40.6]	Total BTUH [kW] Sens BTUH [kW] Power	150.3 [44.1] 88.4 [25.9] 12.6	145.1 [42.5] 80.8 [23.7] 12.4	139.8 [41.0] 73.3 [21.5] 12.1	140.6 [41.2] 109.6 [32.1] 12.3	135.7 [39.8] 100.2 [29.4] 12.1	130.8 [38.3] 90.9 [26.6] 11.9	132.7 [38.9] 127.2 [37.3] 12.1	128 [37.5] 116.3 [34.1] 11.9	123.4 [36.1] 105.5 [30.9] 11.7
	110 [43.3]	Total BTUH [kW] Sens BTUH [kW] Power	144.6 [42.4] 84.4 [24.7] 13.2	139.6 [40.9] 77.2 [22.6] 13	134.5 [39.4] 70 [20.5] 12.8	134.9 [39.5] 105.6 [30.9] 13	130.2 [38.2] 96.6 [28.3] 12.8	125.5 [36.8] 87.6 [25.7] 12.6	126.9 [37.2] 123.2 [36.1] 12.8	122.5 [35.9] 112.7 [33] 12.6	118 [34.6] 102.2 [29.9] 12.3
	115 [46.1]	Total BTUH [kW] Sens BTUH [kW] Power	138.7 [40.7] 79.8 [23.4] 13.9	133.9 [39.2] 73 [21.4] 13.7	129 [37.8] 66.2 [19.4] 13.4	129 [37.8] 101 [29.6] 13.7	124.5 [36.5] 92.4 [27.1] 13.5	120 [35.2] 83.8 [24.5] 13.2	121 [35.5] 118.6 [34.8] 13.5	116.8 [34.2] 108.5 [31.8] 13.2	112.6 [33] 98.4 [28.8] 13
	120 [48.9]	Total BTUH [kW] Sens BTUH [kW] Power	132.6 [38.9] 74.6 [21.8] 14.7	128 [37.5] 68.2 [20.0] 14.4	123.3 [36.1] 61.8 [18.1] 14.1	122.9 [36.0] 95.8 [28.1] 14.4	118.6 [34.8] 87.6 [25.7] 14.2	114.3 [33.5] 79.4 [23.3] 13.9	115 [33.7] 113.4 [33.2] 14.2	110.9 [32.5] 103.7 [30.4] 14	106.9 [31.3] 94 [27.6] 13.7
	125 [51.7]	Total BTUH [kW] Sens BTUH [kW] Power	126.4 [37.0] 68.7 [20.1] 15.4	121.9 [35.7] 62.8 [18.4] 15.1	117.5 [34.4] 56.9 [16.7] 14.9	116.7 [34.2] 89.9 [26.3] 15.2	112.6 [33.0] 82.2 [24.1] 14.9	108.5 [31.8] 74.5 [21.8] 14.7	108.7 [31.8] 107.5 [31.5] 15	104.9 [30.7] 98.3 [28.8] 14.7	101 [29.6] 89.1 [26.1] 14.4

DR —Depression ratio  
dbE —Entering air dry bulb  
wbE—Entering air wet bulb

Total —Total capacity x 1000 BTUH  
Sens —Sensible capacity x 1000 BTUH  
Power —KW input

NOTES: ① When the entering air dry bulb is other than 80°F [27°C], adjust the sensible capacity from the table by adding [1.10 x CFM x (1 – DR) x (dbE – 80)].

[ ] Designates Metric Conversions



# AIRFLOW PERFORMANCE—7.5 TON [26.4 kW] (B090)

Air Flow CFM [L/s]	Capacity 7.5 Ton [26.4 kW]																			
	External Static Pressure—Inches of Water [kPa]																			
	0.1 [0.02]	0.2 [0.05]	0.3 [0.07]	0.4 [0.10]	0.5 [0.12]	0.6 [0.15]	0.7 [0.17]	0.8 [0.20]	0.9 [0.22]	1.0 [0.25]	1.1 [0.27]	1.2 [0.30]	1.3 [0.32]	1.4 [0.35]	1.5 [0.37]	1.6 [0.40]	1.7 [0.42]	1.8 [0.45]	1.9 [0.47]	2.0 [0.50]
2400 [1133]	—	—	—	540	580	620	664	704	749	791	831	871	911	952	992	1032	1072	1112	1152	1192
2500 [1180]	—	—	—	552	633	693	753	813	873	933	993	1053	1113	1173	1233	1293	1353	1413	1473	1533
2600 [1227]	—	—	—	564	687	769	853	937	1021	1105	1189	1273	1357	1441	1525	1609	1693	1777	1861	1945
2700 [1274]	—	—	—	576	733	827	921	1015	1109	1203	1297	1391	1485	1579	1673	1767	1861	1955	2049	2143
2800 [1321]	—	—	—	588	783	891	1000	1109	1218	1327	1436	1545	1654	1763	1872	1981	2090	2199	2308	2417
2900 [1369]	—	—	—	600	821	941	1061	1181	1301	1421	1541	1661	1781	1901	2021	2141	2261	2381	2501	2621
3000 [1416]	—	—	—	612	854	984	1114	1244	1374	1504	1634	1764	1894	2024	2154	2284	2414	2544	2674	2804
3100 [1463]	—	—	—	624	886	1026	1166	1306	1446	1586	1726	1866	2006	2146	2286	2426	2566	2706	2846	2986
3200 [1510]	—	—	—	636	918	1068	1218	1368	1518	1668	1818	1968	2118	2268	2418	2568	2718	2868	3018	3168
3300 [1557]	—	—	—	648	950	1110	1270	1430	1590	1750	1910	2070	2230	2390	2550	2710	2870	3030	3190	3350
3400 [1605]	—	—	—	660	1000	1170	1350	1530	1710	1890	2070	2250	2430	2610	2790	2970	3150	3330	3510	3690
3500 [1652]	—	—	—	672	1050	1230	1420	1610	1800	1990	2180	2370	2560	2750	2940	3130	3320	3510	3700	3890
3600 [1699]	—	—	—	684	1100	1290	1490	1690	1890	2090	2290	2490	2690	2890	3090	3290	3490	3690	3890	4090

Drive Package	L						M						N												
Motor H.P. [W]	2.0 [1491.4]						2.0 [1491.4]						3.0 [2237.1]												
Blower Sheave	BK110						BK90						BK65												
Motor Sheave	1VP-44						1VP-44						1VP-44												
Turns Open	1	2	3	4	5	6	1	2	3	4	5	6	1	2	3	4	5	6	1	2	3	4	5	6	
RPM	682	650	620	587	555	523	806	774	742	710	678	646	614	582	550	518	1005	954	903	852	801	750	699	648	597

- NOTES: 1. Factory sheave settings are shown in bold print.  
 2. Re-adjustment of sheave required to achieve rated airflow at AHRI minimum E.S.P.  
 3. Do not operate above blower RPM shown as motor overloading will occur.  
 4. Do not set motor sheave below one turn open.

# AIRFLOW CORRECTION FACTORS 7.5 TON [26.4 kW] (B090)

ACTUAL—CFM [L/s]	2600 [1227]	2800 [1321]	3000 [1416]	3200 [1510]	3400 [1605]	3600 [1699]	3800 [1793]
TOTAL MBH	0.97	0.98	0.99	1.00	1.01	1.02	1.03
SENSIBLE MBH	0.91	0.94	0.97	1.00	1.02	1.05	1.08
POWER kW	0.99	0.99	0.99	1.00	1.00	1.01	1.02

- NOTES: 1. Multiply correction factor times gross performance data.  
 2. Resulting sensible capacity cannot exceed total capacity.

## [ ] Designates Metric Conversions

# COMPONENT AIR RESISTANCE, IWC 7.5 TON [26.4 kW] (B090)

Component	Standard Indoor Airflow—CFM [L/s]													
	2400 [1133]		2600 [1227]		2800 [1321]		3000 [1416]		3200 [1510]		3400 [1604]		3600 [1699]	
	Resistance—Inches Water [kPa]													
Wet Coil	0.047 [0.012]	0.051 [0.013]	0.055 [0.014]	0.060 [0.015]	0.065 [0.016]	0.070 [0.017]	0.075 [0.018]	0.080 [0.019]	0.085 [0.020]	0.090 [0.021]	0.095 [0.022]	0.100 [0.023]	0.105 [0.024]	0.110 [0.025]
Concentric Diffuser RXRN-FA65 or FA75 & Transition RXMC-CD04	DNA	.017 [0.042]	.020 [0.050]	.025 [0.062]	.031 [0.077]	.037 [0.092]	.043 [0.107]	.049 [0.122]	.055 [0.137]	.061 [0.152]	.067 [0.167]	.073 [0.182]	.079 [0.197]	.085 [0.212]
Concentric Diffuser RXRN-AA61 or AA71 & Transition RXMC-CE05	DNA	DNA	DNA	DNA	DNA	DNA	DNA	DNA	DNA	DNA	DNA	DNA	DNA	DNA
Economizer	0.05 [0.012]	0.06 [0.015]	0.07 [0.017]	0.08 [0.020]	0.09 [0.022]	0.10 [0.025]	0.11 [0.027]	0.12 [0.030]	0.13 [0.032]	0.14 [0.034]	0.15 [0.036]	0.16 [0.038]	0.17 [0.040]	0.18 [0.042]
100% R.A. Damper Open	0.03 [0.007]	0.04 [0.009]	0.04 [0.010]	0.05 [0.012]	0.05 [0.012]	0.06 [0.014]	0.06 [0.014]	0.07 [0.016]	0.07 [0.016]	0.08 [0.018]	0.08 [0.018]	0.09 [0.020]	0.09 [0.020]	0.10 [0.022]
Horizontal Economizer	0.03 [0.007]	0.04 [0.009]	0.04 [0.010]	0.05 [0.012]	0.05 [0.012]	0.06 [0.014]	0.06 [0.014]	0.07 [0.016]	0.07 [0.016]	0.08 [0.018]	0.08 [0.018]	0.09 [0.020]	0.09 [0.020]	0.10 [0.022]
100% R.A. Damper Open	0.03 [0.007]	0.04 [0.009]	0.04 [0.010]	0.05 [0.012]	0.05 [0.012]	0.06 [0.014]	0.06 [0.014]	0.07 [0.016]	0.07 [0.016]	0.08 [0.018]	0.08 [0.018]	0.09 [0.020]	0.09 [0.020]	0.10 [0.022]
Horizontal Economizer	0.03 [0.007]	0.04 [0.009]	0.04 [0.010]	0.05 [0.012]	0.05 [0.012]	0.06 [0.014]	0.06 [0.014]	0.07 [0.016]	0.07 [0.016]	0.08 [0.018]	0.08 [0.018]	0.09 [0.020]	0.09 [0.020]	0.10 [0.022]
100% O.A. Damper Open	0.03 [0.007]	0.04 [0.009]	0.04 [0.010]	0.05 [0.012]	0.05 [0.012]	0.06 [0.014]	0.06 [0.014]	0.07 [0.016]	0.07 [0.016]	0.08 [0.018]	0.08 [0.018]	0.09 [0.020]	0.09 [0.020]	0.10 [0.022]

NOTE: Add component resistance to duct resistance to determine total external static pressure.  
 DNA = Data not Available.





ELECTRICAL DATA – RLKL SERIES								
		B090CL	B090CM	B090CN	B090DL	B090DM	B090DN	B090YL
Unit Information	Unit Operating Voltage Range	187-253	187-253	187-253	414-506	414-506	414-506	518-632
	Volts	208/230	208/230	208/230	460	460	460	575
	Minimum Circuit Ampacity	40/40	40/40	45/45	20	20	23	15
	Minimum Overcurrent Protection Device Size	50/50	50/50	60/60	25	25	30	20
	Maximum Overcurrent Protection Device Size	60/60	60/60	60/60	30	30	30	20
Compressor Motor	No.	1	1	1	1	1	1	1
	Volts	200/240	200/240	200/240	480	480	480	600
	Phase	3	3	3	3	3	3	3
	RPM	3450	3450	3450	3450	3450	3450	3450
	HP, Compressor 1	6	6	6	6	6	6	6
	Amps (RLA), Comp. 1	23.2/23.2	23.2/23.2	23.2/23.2	11.2	11.2	11.2	7.9
	Amps (LRA), Comp. 1	164/164	164/164	164/164	75	75	75	54
	HP, Compressor 2	—	—	—	—	—	—	—
	Amps (RLA), Comp. 2	—	—	—	—	—	—	—
	Amps (LRA), Comp. 2	—	—	—	—	—	—	—
Condenser Motor	No.	1	1	1	1	1	1	1
	Volts	208/230	208/230	208/230	460	460	460	575
	Phase	1	1	1	1	1	1	1
	HP	1/2	1/2	1/2	1/2	1/2	1/2	1/2
	Amps (FLA, each)	2.3/2.3	2.3/2.3	2.3/2.3	1.5	1.5	1.5	1
	Amps (LRA, each)	5.6/5.6	5.6/5.6	5.6/5.6	3.1	3.1	3.1	2.2
Evaporator Fan	No.	1	1	1	1	1	1	1
	Volts	208/230	208/230	208/230	460	460	460	575
	Phase	3	3	3	3	3	3	3
	HP	2	2	3	2	2	3	2
	Amps (FLA, each)	8/8	8/8	13/13	4	4	7	4
	Amps (LRA, each)	56/56	56/56	74.5/74.5	28	28	38.1	19

### ELECTRICAL DATA – RLKL SERIES

		<b>B090YM</b>	<b>B090YN</b>	<b>B120CL</b>	<b>B120CM</b>	<b>B120DL</b>	<b>B120DM</b>	<b>B120YL</b>
<b>Unit Information</b>	Unit Operating Voltage Range	518-632	518-632	187-253	187-253	414-506	414-506	518-632
	Volts	575	575	208/230	208/230	460	460	575
	Minimum Circuit Ampacity	15	19	51/51	56/56	28	31	22
	Minimum Overcurrent Protection Device Size	20	25	60/60	70/70	35	35	25
	Maximum Overcurrent Protection Device Size	20	25	80/80	80/80	40	45	30
<b>Compressor Motor</b>	No.	1	1	1	1	1	1	1
	Volts	600	600	200/240	200/240	480	480	600
	Phase	3	3	3	3	3	3	3
	RPM	3450	3450	3450	3450	3450	3450	3450
	HP, Compressor 1	6	6	10	10	10	10	10
	Amps (RLA), Comp. 1	7.9	7.9	30.1/30.1	30.1/30.1	16.7	16.7	12.2
	Amps (LRA), Comp. 1	54	54	225/225	225/225	114	114	80
	HP, Compressor 2	—	—	—	—	—	—	—
	Amps (RLA), Comp 2	—	—	—	—	—	—	—
Amps (LLA), Comp 2	—	—	—	—	—	—	—	
<b>Condenser Motor</b>	No.	1	1	2	2	2	2	2
	Volts	575	575	208/230	208/230	460	460	575
	Phase	1	1	1	1	1	1	1
	HP	1/2	1/2	1/3	1/3	1/3	1/3	1/3
	Amps (FLA, each)	1	1	2.4/2.4	2.4/2.4	1.4	1.4	1
	Amps (LRA, each)	2.2	2.2	4.7/4.7	4.7/4.7	2.4	2.4	1.5
<b>Evaporator Fan</b>	No.	1	1	1	1	1	1	1
	Volts	575	575	208/230	208/230	460	460	575
	Phase	3	3	3	3	3	3	3
	HP	2	3	2	3	2	3	2
	Amps (FLA, each)	4	8	8/8	13/13	4	7	4
	Amps (LRA, each)	19	20	56/56	74.5/74.5	28	38.1	19



<b>ELECTRICAL DATA – RLKL SERIES</b>								
		<b>B120YM</b>	<b>B151CL</b>	<b>B151CM</b>	<b>B151DL</b>	<b>B151DM</b>	<b>B151YL</b>	<b>B151YM</b>
<b>Unit Information</b>	Unit Operating Voltage Range	518-632	187-253	187-253	414-506	414-506	518-632	518-632
	Volts	575	208/230	208/230	460	460	575	575
	Minimum Circuit Ampacity	26	67/67	71/71	33	36	28	28
	Minimum Overcurrent Protection Device Size	30	70/70	75/75	35	40	30	30
	Maximum Overcurrent Protection Device Size	35	80/80	90/90	40	45	35	35
<b>Compressor Motor</b>	No.	1	2	2	2	2	2	2
	Volts	600	208/230	208/230	460	460	575	575
	Phase	3	3	3	3	3	3	3
	RPM	3450	3450	3450	3450	3450	3450	3450
	HP, Compressor 1	10	5 3/4	5 3/4	5 3/4	5 3/4	5 3/4	5 3/4
	Amps (RLA), Comp. 1	12.2	22.4/22.4	22.4/22.4	10.6	10.6	7.7	7.7
	Amps (LRA), Comp. 1	80	149/149	149/149	75	75	54	54
	HP, Compressor 2	—	5 1/4	5 1/4	5 1/4	5 1/4	5 1/4	5 1/4
	Amps (RLA), Comp 2	—	19/19	19/19	9.7	9.7	7.4	7.4
Amps (LLA), Comp 2	—	123/123	123/123	62	62	50	50	
<b>Condenser Motor</b>	No.	2	2	2	2	2	2	2
	Volts	575	208/230	208/230	460	460	575	575
	Phase	1	1	1	1	1	1	1
	HP	1/3	1/2	1/2	1/2	1/2	1/2	1/2
	Amps (FLA, each)	1	2.3/2.3	2.3/2.3	1.5	1.5	1	1
	Amps (LRA, each)	1.5	5.6/5.6	5.6/5.6	3.1	3.1	2.2	2.2
<b>Evaporator Fan</b>	No.	1	1	1	1	1	1	1
	Volts	575	208/230	208/230	460	460	575	575
	Phase	3	3	3	3	3	3	3
	HP	3	3	5	3	5	3	5
	Amps (FLA, each)	8	15/15	18.8/18.8	7	10	8	8
	Amps (LRA, each)	20	74.5/74.5	82.6/82.6	38.1	41.3	20	33



Air

Electric Heater Kits  
RLKL-B Series

208/240 VOLT, THREE PHASE, 60 HZ, AUXILIARY ELECTRIC HEATER KITS CHARACTERISTICS AND APPLICATION															
Separate Power Supply For Both Unit and Heater Kit															
Unit Model No. RLKL-	Single Power Supply For Both Unit and Heater Kit					Air Conditioner					Heater Kit				
	RXJJ- Heater Kit Nominal kW	No. of Sequence Steps	Rated Heater kW @ 208/240 V	Heater KBTU/Hr @ 208/240 V	Heater Amp. @ 208/240 V	Unit Min. Ckt. Ampacity @ 208/240 V	Over Current Protective Device Size		Air Conditioner		Min. Ckt. Ampacity 208/240 V	Max. Fuse Size 208/240 V	Min. Circuit Ampacity 208/240 V	Over Current Protective Device Size	
							Min. @ 208 V	Max. @ 240 V	Min. @ 208 V	Max. @ 240 V			Min. @ 208 V	Max. @ 240 V	
B090CL	No Heat	—	—	—	—	40/40	50/60	50/60	50/60	50/60	—	—	40/40	50/60	50/60
	CC10C	1	7.2/9.6	24.56/32.75	20/23.1	40/40	50/60	50/60	50/60	50/60	25/29	25/30	—	—	—
	CC15C	1	10.8/14.4	36.84/49.13	30/34.6	48/54	50/60	60/60	60/60	60/60	38/44	40/45	—	—	—
	CC20C	1	14.4/19.2	49.13/65.5	40/46.2	60/68	60/60	70/70	60/60	60/60	50/58	50/60	—	—	—
	CC30C	1	21.6/28.8	73.69/98.25	60/69.3	85/97	90/90	100/100	90/90	100/100	75/87	80/90	—	—	—
B120CL	CC31C	1	21.6/28.8	73.69/98.25	60/69.3	85/97	90/90	100/100	90/90	100/100	75/87	80/90	—	—	—
	CC40C	1	28.8/38.4	98.25/131	80.1/92.4	111/126	125/125	150/150	125/125	150/150	101/116	110/125	—	—	—
	CC41C	1	28.8/38.4	98.25/131	80.1/92.4	111/126	125/125	150/150	125/125	150/150	101/116	110/125	—	—	—
	No Heat	—	—	—	—	51/51	60/80	60/80	60/80	60/80	—	—	51/51	60/80	60/80
	CC10C	1	7.2/9.6	24.56/32.75	20/23.1	51/51	60/80	60/80	60/80	60/80	25/29	25/30	—	—	—
B151CL	CC15C	1	10.8/14.4	36.84/49.13	30/34.6	51/54	60/80	60/80	60/80	60/80	38/44	40/45	—	—	—
	CC20C	1	14.4/19.2	49.13/65.5	40/46.2	60/68	60/80	70/80	60/80	60/80	50/58	50/60	—	—	—
	CC30C	1	21.6/28.8	73.69/98.25	60/69.3	85/97	90/90	100/100	90/90	100/100	75/87	80/90	—	—	—
	CC40C	1	28.8/38.4	98.25/131	80.1/92.4	111/126	125/125	150/150	125/125	150/150	101/116	110/125	—	—	—
	CC50C	1	36.1/48	123.16/163.75	100.1/115.5	136/155	150/150	175/175	150/150	175/175	126/145	150/150	—	—	—
B090CM	No Heat	—	—	—	—	67/67	70/80	70/80	70/80	70/80	—	—	67/67	70/80	70/80
	CC10C	1	7.2/9.6	24.56/32.75	20/23.1	67/67	80/80	80/80	80/80	80/80	25/29	25/30	—	—	—
	CC15C	1	10.8/14.4	36.84/49.13	30/34.6	67/67	80/80	80/80	80/80	80/80	38/44	40/45	—	—	—
	CC20C	1	14.4/19.2	49.13/65.5	40/46.2	69/77	80/80	80/80	80/80	80/80	50/58	50/60	—	—	—
	CC30C	1	21.6/28.8	73.69/98.25	60/69.3	94/106	100/100	110/110	100/100	100/100	75/87	80/90	—	—	—
B120CM	CC40C	1	28.8/38.4	98.25/131	80.1/92.4	119/135	125/125	150/150	125/125	150/150	101/116	110/125	—	—	—
	CC50C	1	36.1/48	123.16/163.75	100.1/115.5	144/164	150/150	175/175	150/150	175/175	126/145	150/150	—	—	—
	No Heat	—	—	—	—	40/40	50/60	50/60	50/60	50/60	—	—	40/40	50/60	50/60
	CC10C	1	7.2/9.6	24.56/32.75	20/23.1	40/40	50/60	50/60	50/60	50/60	25/29	25/30	—	—	—
	CC15C	1	10.8/14.4	36.84/49.13	30/34.6	48/54	50/60	60/60	60/60	60/60	38/44	40/45	—	—	—

\*= For Canadian use only. Uses "P" fuses for inductive circuit.  
+ = Field installed only.



208/240 VOLT, THREE PHASE, 60 HZ, AUXILIARY ELECTRIC HEATER KITS CHARACTERISTICS AND APPLICATION															
Separate Power Supply For Both Unit and Heater Kit															
Single Power Supply For Both Unit and Heater Kit															
Unit Model No. RLKL-	Heater Kit					Air Conditioner				Heater Kit				Air Conditioner	
	RXJJ- Heater Kit Nominal kW	No. of Sequence Steps	Rated Heater kW @ 208/240 V	Heater KBTU/Hr @ 208/240 V	Heater Amp. @ 208/240 V	Unit Min. Ckt. Ampacity @ 208/240 V	Over Current Protective Device Size Min./Max. @ 208 V	Over Current Protective Device Size Min./Max. @ 240 V	Min. Ckt. Ampacity 208/240 V	Max. Fuse Size 208/240 V	Min. Circuit Ampacity 208/240 V	Over Current Protective Device Size Min./Max. @ 208 V	Over Current Protective Device Size Min./Max. @ 240 V		
C151CM	No Heat	—	—	—	—	71/71	75/90	75/90	—	—	71/71	75/90	75/90		
	CC10C	1	7.2/9.6	24.56/32.75	20/23.1	71/71	80/90	80/90	25/29	25/30	—	—	—		
	CC15C	1	10.8/14.4	36.84/49.13	30/34.6	71/71	80/90	80/90	38/44	40/45	—	—	—		
	CC20C	1	14.4/19.2	49.13/65.5	40/46.2	74/82	80/90	90/90	50/58	50/60	—	—	—		
	CC30C	1	21.6/28.8	73.69/98.25	60/69.3	99/111	100/100	125/125	75/87	80/90	—	—	—		
B090CN	CC40C	1	28.8/38.4	98.25/131	80.1/92.4	124/140	125/125	150/150	101/116	110/125	—	—	—		
	CC50C	1	36.1/48	123.16/163.75	100.1/115.5	149/168	150/150	175/175	126/145	150/150	—	—	—		
	No Heat	—	—	—	—	45/45	60/60	60/60	—	—	45/45	60/60	60/60		
	CC10C	1	7.2/9.6	24.56/32.75	20/23.1	45/46	60/60	60/60	25/29	25/30	—	—	—		
	CC15C	1	10.8/14.4	36.84/49.13	30/34.6	54/60	60/60	60/60	38/44	40/45	—	—	—		
B090CN	CC20C	1	14.4/19.2	49.13/65.5	40/46.2	67/75	70/70	80/80	50/58	50/60	—	—	—		
	CC30C	1	21.6/28.8	73.69/98.25	60/69.3	92/103	100/100	110/110	75/87	80/90	—	—	—		
	CC31C	1	21.6/28.8	73.69/98.25	60/69.3	92/103	100/100	110/110	75/87	80/90	—	—	—		
	CC40C	1	28.8/38.4	98.25/131	80.1/92.4	117/132	125/125	150/150	101/116	110/125	—	—	—		
CC41C	1	28.8/38.4	98.25/131	80.1/92.4	117/132	125/125	150/150	101/116	110/125	—	—	—			

\*= For Canadian use only. Uses "P" fuses for inductive circuit.

+ = Field installed only.



## 480 VOLT, THREE PHASE, 60 HZ, AUXILIARY ELECTRIC HEATER KITS CHARACTERISTICS AND APPLICATION

Single Power Supply For Both Unit and Heater Kit										Separate Power Supply For Both Unit and Heater Kit					
Unit Model No. RLKL-	Heater Kit					Air Conditioner					Heater Kit			Air Conditioner	
	RXJJ- Heater Kit Nominal kW	No. of Sequence Steps	Rated Heater kW @ 480 V	Heater KBTU/Hr @ 480 V	Heater Amp. @ 480 V	Unit Min. Ckt. Ampacity @ 480 V	Over Current Protective Device Size @ 480 V		Min. Circuit Ampacity @ 480 V	Max. Fuse Size @ 480 V	Min. Ckt. Ampacity @ 480 V	Min. /Max. @ 480 V	Over Current Protective Device Size @ 480 V	Min. /Max. @ 480 V	
B090DL	No Heat	—	—	—	—	20	25/30	—	—	—	20	25/30	—	—	
	CC10D	1	9.6	32.75	11.5	20	25/30	15	15	15	20	25/30	—	—	
	CC15D	1	14.4	49.13	17.3	27	30/30	22	25	22	—	—	—	—	
	CC20D	1	19.2	65.5	23.1	34	35/35	29	30	29	—	—	—	—	
	CC30D	1	28.8	98.25	34.6	49	50/50	44	45	44	—	—	—	—	
	CC40D	1	38.4	131	46.2	63	70/70	58	60	58	—	—	—	—	
B120DL	No Heat	—	—	—	—	28	35/40	—	—	—	28	35/40	—	—	
	CC10D	1	9.6	32.75	11.5	28	35/40	15	15	15	28	35/40	—	—	
	CC15D	1	14.4	49.13	17.3	28	35/40	22	25	22	—	—	—	—	
	CC20D	1	19.2	65.5	23.1	34	35/40	29	30	29	—	—	—	—	
	CC30D	1	28.8	98.25	34.6	49	50/50	44	45	44	—	—	—	—	
	CC40D	1	38.4	131	46.2	63	70/70	58	60	58	—	—	—	—	
B151DL	No Heat	—	—	—	—	33	35/40	—	—	—	33	35/40	—	—	
	CC10D	1	9.6	32.75	11.5	33	40/40	15	15	15	33	35/40	—	—	
	CC15D	1	14.4	49.13	17.3	33	40/40	22	25	22	—	—	—	—	
	CC20D	1	19.2	65.5	23.1	38	40/40	29	30	29	—	—	—	—	
	CC30D	1	28.8	98.25	34.6	52	60/60	44	45	44	—	—	—	—	
	CC40D	1	38.4	131	46.2	67	70/70	58	60	58	—	—	—	—	
B090DM	No Heat	—	—	—	—	20	25/30	—	—	—	20	25/30	—	—	
	CC10D	1	9.6	32.75	11.5	20	25/30	15	15	15	20	25/30	—	—	
	CC15D	1	14.4	49.13	17.3	27	30/30	22	25	22	—	—	—	—	
	CC20D	1	19.2	65.5	23.1	34	35/35	29	30	29	—	—	—	—	
	CC30D	1	28.8	98.25	34.6	49	50/50	44	45	44	—	—	—	—	
	CC40D	1	38.4	131	46.2	63	70/70	58	60	58	—	—	—	—	
B120DM	No Heat	—	—	—	—	31	35/45	—	—	—	31	35/45	—	—	
	CC10D	1	9.6	32.75	11.5	31	35/45	15	15	15	31	35/45	—	—	
	CC15D	1	14.4	49.13	17.3	31	35/45	22	25	22	—	—	—	—	
	CC20D	1	19.2	65.5	23.1	38	40/45	29	30	29	—	—	—	—	
	CC30D	1	28.8	98.25	34.6	52	60/60	44	45	44	—	—	—	—	
	CC40D	1	38.4	131	46.2	67	70/70	58	60	58	—	—	—	—	

\*= For Canadian use only. Uses "P" fuses for inductive circuit.  
+ = Field installed only.



Air

Electric Heater Kits  
RLKL-B Series**480 VOLT, THREE PHASE, 60 HZ, AUXILIARY ELECTRIC HEATER KITS CHARACTERISTICS AND APPLICATION**

Single Power Supply For Both Unit and Heater Kit										Separate Power Supply For Both Unit and Heater Kit										
Unit Model No. RLKL-	Heater Kit					Air Conditioner					Heater Kit					Air Conditioner				
	RXJJ- Heater Kit Nominal kW	No. of Sequence Steps	Rated Heater kW @ 480 V	Heater KBTU/Hr @ 480 V	Heater Amp. @ 480 V	Unit Min. Ckt. Ampacity @ 480 V	Over Current Protective Device Size Min./Max. @ 480 V	Min. Ckt. Ampacity 480 V	Max. Fuse Size 480 V	Min. Circuit Ampacity 480 V	Over Current Protective Device Size Min./Max. @ 480 V	Over Current Protective Device Size Min./Max. @ 480 V								
B151DM	No Heat	—	—	—	—	36	40/45	—	—	36	40/45	—								
	CC10D	1	9.6	32.75	11.5	36	40/45	15	15	—	—	—								
	CC15D	1	14.4	49.13	17.3	36	40/45	22	25	—	—	—								
	CC20D	1	19.2	65.5	23.1	42	45/45	29	30	—	—	—								
	CC30D	1	28.8	98.25	34.6	56	60/60	44	45	—	—	—								
	CC40D	1	38.4	131	46.2	71	80/80	58	60	—	—	—								
B090DN	CC50D	1	48	163.75	57.7	85	90/90	73	80	—	—	—								
	No Heat	—	—	—	—	23	30/30	—	—	23	30/30	—								
	CC10D	1	9.6	32.75	11.5	24	30/30	15	15	—	—	—								
	CC15D	1	14.4	49.13	17.3	31	35/35	22	25	—	—	—								
	CC20D	1	19.2	65.5	23.1	38	40/40	29	30	—	—	—								
	CC30D	1	28.8	98.25	34.6	52	60/60	44	45	—	—	—								
	CC31D	1	28.8	98.25	34.6	52	60/60	44	45	—	—	—								
	CC40D	1	38.4	131	46.2	67	70/70	58	60	—	—	—								
	CC41D	1	38.4	131	46.2	67	70/70	58	60	—	—	—								
	CC41D	1	38.4	131	46.2	67	70/70	58	60	—	—	—								

\* = For Canadian use only. Uses "P" fuses for inductive circuit.

+ = Field installed only.





**600 VOLT, THREE PHASE, 60 HZ, AUXILIARY ELECTRIC HEATER KITS CHARACTERISTICS AND APPLICATION**

**Separate Power Supply For Both Unit and Heater Kit**

Unit Model No. RLKL-	Single Power Supply For Both Unit and Heater Kit						Separate Power Supply For Both Unit and Heater Kit					
	Heater Kit			Air Conditioner			Heater Kit			Air Conditioner		
	RXJJ-Heater Kit Nominal kW	No. of Sequence Steps	Rated Heater kW @ 600 V	Heater KBTU/Hr @ 600 V	Heater Amp. @ 600 V	Unit Min. Ckt. Ampacity @ 600 V	Over Current Protective Device Size Min./Max. @ 600 V	Min. Ckt. Ampacity 600 V	Max. Fuse Size 600 V	Min. Circuit Ampacity 600 V	Over Current Protective Device Size Min./Max. @ 600 V	
B090YL	No Heat	—	—	—	—	15	20/20	—	—	15	20/20	
	CC10Y	1	9.6	32.75	9.2	17	20/20	12	15	—	—	
	CC15Y	1	14.4	49.13	13.9	23	25/25	18	20	—	—	
	CC20Y	1	19.2	65.5	18.5	29	30/30	24	25	—	—	
	CC30Y	1	28.8	98.25	27.7	40	40/40	35	35	—	—	
CC40Y	1	38.4	131	37	52	60/60	47	50	—	—		
B120YL	No Heat	—	—	—	—	22	25/30	—	—	22	25/30	
	CC10Y	1	9.6	32.75	9.2	22	25/30	12	15	—	—	
	CC15Y	1	14.4	49.13	13.9	23	25/30	18	20	—	—	
	CC20Y	1	19.2	65.5	18.5	29	30/30	24	25	—	—	
	CC30Y	1	28.8	98.25	27.7	40	40/40	35	35	—	—	
CC40Y	1	38.4	131	37	52	60/60	47	50	—	—		
CC50Y	1	48	163.75	46.2	63	70/70	58	60	—	—		
B151YL	No Heat	—	—	—	—	28	30/35	—	—	28	30/35	
	CC10Y	1	9.6	32.75	9.2	28	30/35	12	15	—	—	
	CC15Y	1	14.4	49.13	13.9	28	30/35	18	20	—	—	
	CC20Y	1	19.2	65.5	18.5	34	35/35	24	25	—	—	
	CC30Y	1	28.8	98.25	27.7	45	45/45	35	35	—	—	
CC40Y	1	38.4	131	37	57	60/60	47	50	—	—		
CC50Y	1	48	163.75	46.2	68	70/70	58	60	—	—		
B090YM	No Heat	—	—	—	—	15	20/20	—	—	15	20/20	
	CC10Y	1	9.6	32.75	9.2	17	20/20	12	15	—	—	
	CC15Y	1	14.4	49.13	13.9	23	25/25	18	20	—	—	
	CC20Y	1	19.2	65.5	18.5	29	30/30	24	25	—	—	
	CC30Y	1	28.8	98.25	27.7	40	40/40	35	35	—	—	
CC40Y	1	38.4	131	37	52	60/60	47	50	—	—		
B120YM	No Heat	—	—	—	—	26	30/35	—	—	26	30/35	
	CC10Y	1	9.6	32.75	9.2	26	30/35	12	15	—	—	
	CC15Y	1	14.4	49.13	13.9	28	30/35	18	20	—	—	
	CC20Y	1	19.2	65.5	18.5	34	35/35	24	25	—	—	
	CC30Y	1	28.8	98.25	27.7	45	45/45	35	35	—	—	
CC40Y	1	38.4	131	37	57	60/60	47	50	—	—		
CC50Y	1	48	163.75	46.2	68	70/70	58	60	—	—		

\*= For Canadian use only. Uses "p" fuses for inductive circuit.  
+ = Field installed only.



600 VOLT, THREE PHASE, 60 HZ, AUXILIARY ELECTRIC HEATER KITS CHARACTERISTICS AND APPLICATION														
Separate Power Supply For Both Unit and Heater Kit														
Unit Model No. RLKL-	Single Power Supply For Both Unit and Heater Kit						Separate Power Supply For Both Unit and Heater Kit							
	Heater Kit			Air Conditioner			Heater Kit			Air Conditioner				
RXJJ- Heater Kit Nominal kW	No. of Sequence Steps	Rated Heater kW @ 600 V	Heater KBTU/Hr @ 600 V	Heater Amp. @ 600 V	Unit Min. Ckt. Ampacity @ 600 V	Over Current Protective Device Size Min./Max. @ 600 V	Min. Ckt. Ampacity 600 V	Max. Fuse Size 600 V	Min. Circuit Ampacity 600 V	Over Current Protective Device Size Min./Max. @ 600 V	Min. Ckt. Ampacity 600 V	Max. Fuse Size 600 V	Min. Circuit Ampacity 600 V	Over Current Protective Device Size Min./Max. @ 600 V
B151YM	No Heat	—	—	—	28	30/35	—	—	28	30/35	—	—	28	30/35
	CC10Y	9.6	32.75	9.2	28	30/35	12	15	—	—	—	—	—	—
	CC15Y	14.4	49.13	13.9	28	30/35	18	20	—	—	—	—	—	—
	CC20Y	19.2	65.5	18.5	34	35/35	24	25	—	—	—	—	—	—
	CC30Y	28.8	98.25	27.7	45	45/45	35	35	—	—	—	—	—	—
	CC40Y	38.4	131	37	57	60/60	47	50	—	—	—	—	—	—
B090YN	CC50Y	48	163.75	46.2	68	70/70	58	60	—	—	—	—	—	—
	No Heat	—	—	—	19	25/25	—	—	19	25/25	—	—	19	25/25
	CC10Y	9.6	32.75	9.2	22	25/25	12	15	—	—	—	—	—	—
	CC15Y	14.4	49.13	13.9	28	30/30	18	20	—	—	—	—	—	—
	CC20Y	19.2	65.5	18.5	34	35/35	24	25	—	—	—	—	—	—
	CC30Y	28.8	98.25	27.7	45	45/45	35	35	—	—	—	—	—	—
CC40Y	38.4	131	37	57	60/60	47	50	—	—	—	—	—	—	

\*= For Canadian use only. Uses "P" fuses for inductive circuit.  
 + = Field installed only.

# PACKAGE AIR CONDITIONER

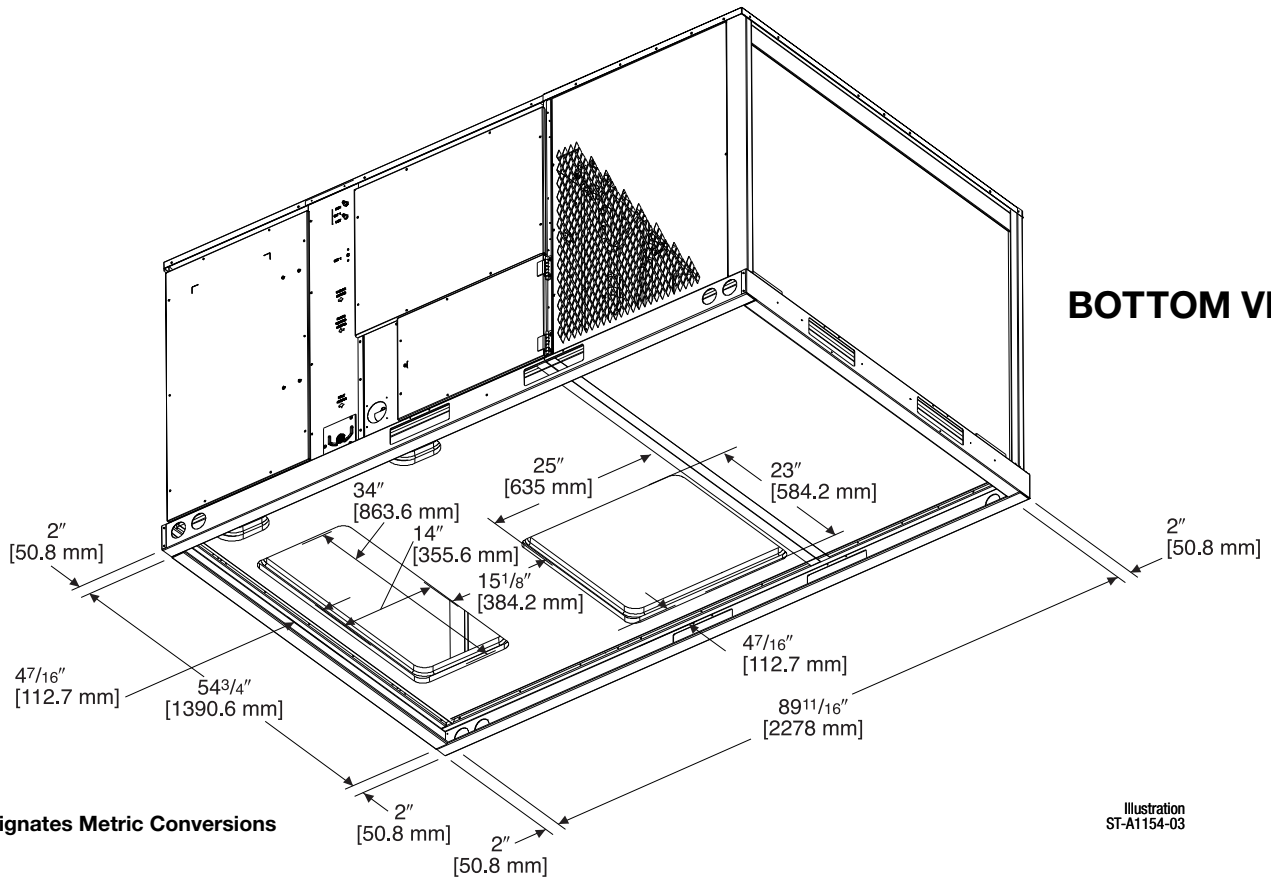
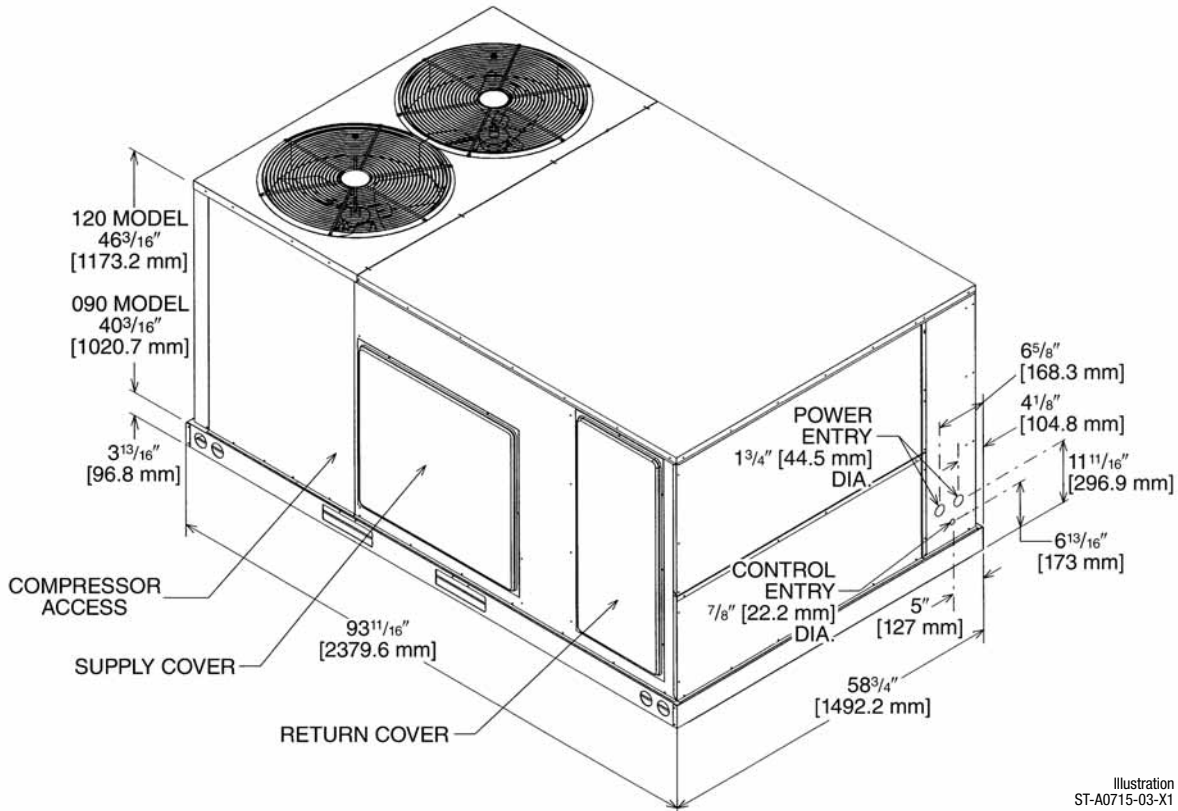

[ ] Designates Metric Conversions



# PACKAGE AIR CONDITIONER

## SUPPLY AND RETURN DIMENSIONS FOR HORIZONTAL APPLICATIONS

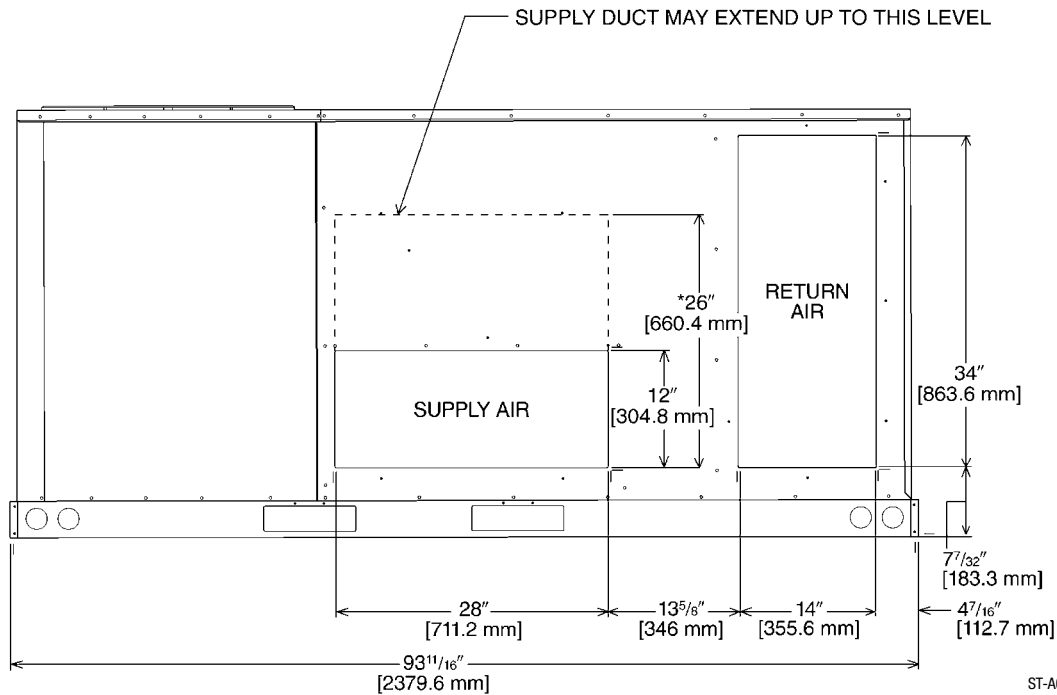

\*RECOMMENDED DUCT DIMENSIONS ARE 26"

## SUPPLY AND RETURN DIMENSIONS FOR DOWNFLOW APPLICATIONS

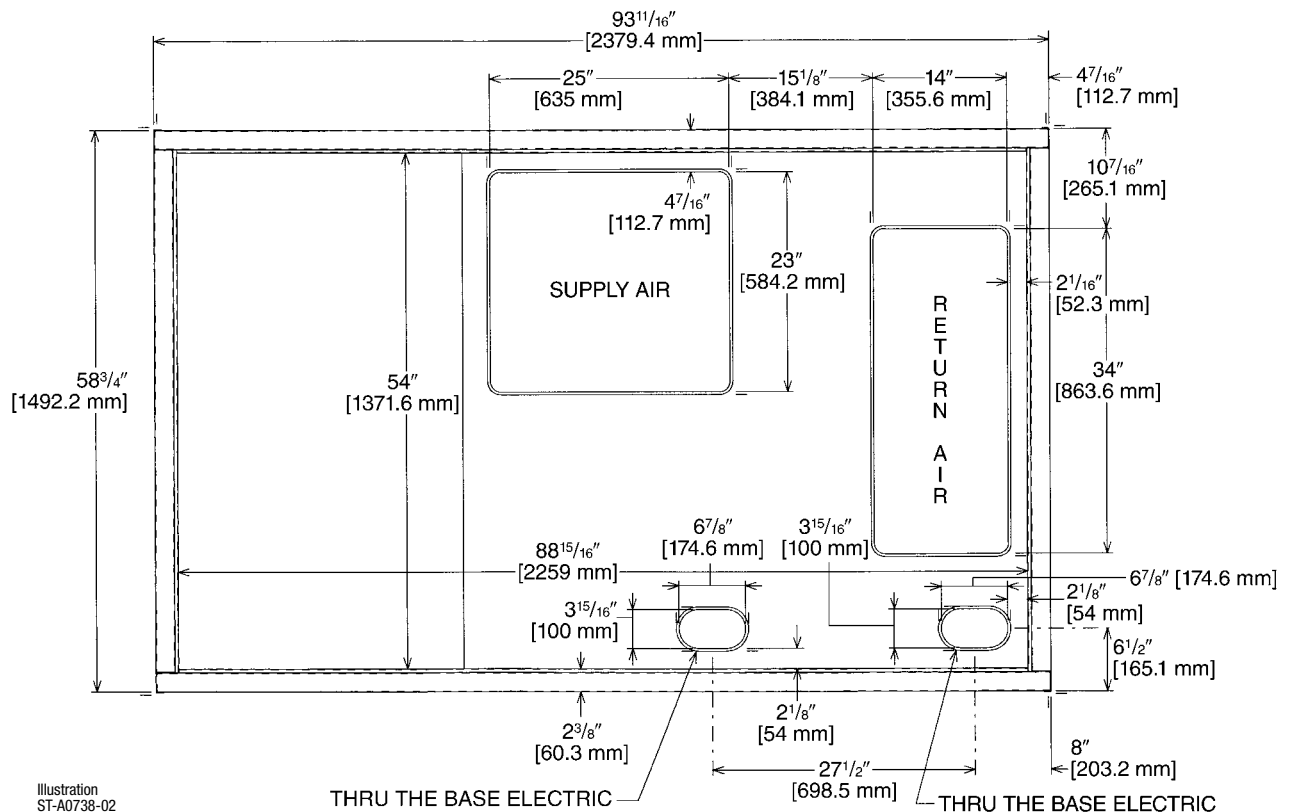

[ ] Designates Metric Conversions

# PACKAGE AIR CONDITIONER

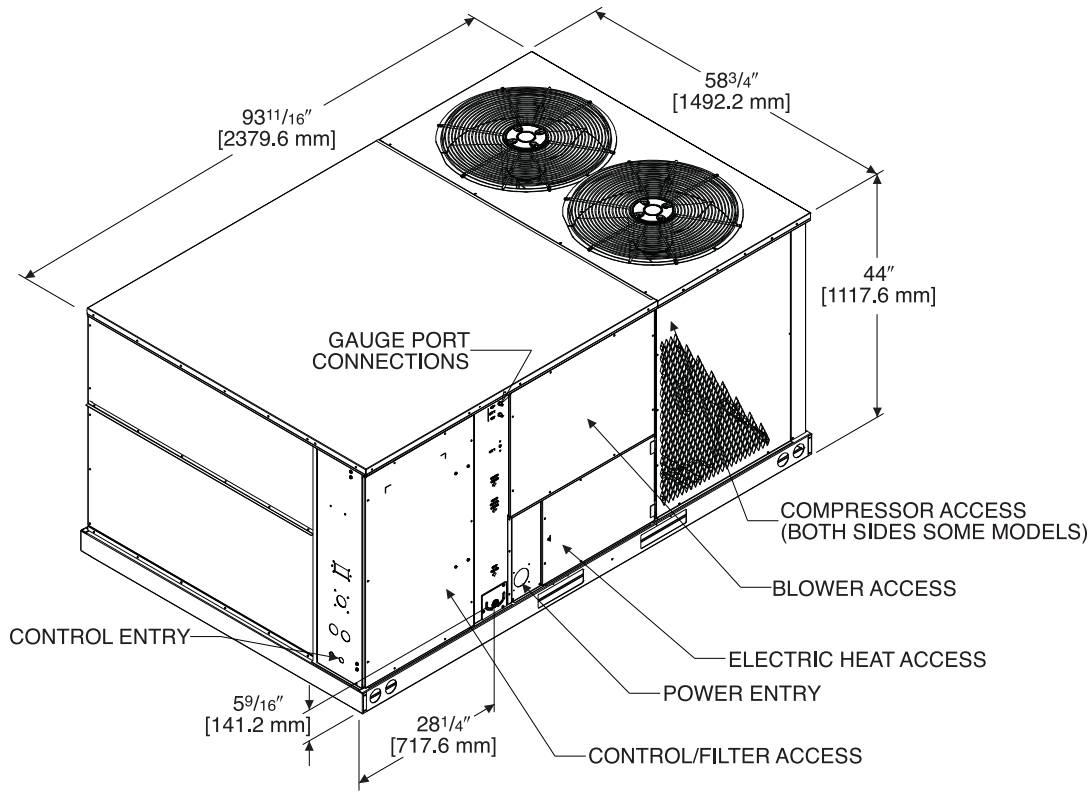

[ ] Designates Metric Conversions

Illustration  
ST-A1154-04

# WEIGHTS

Accessory	Shipping—lbs [kg]	Operating—lbs [kg]
Economizer	90 [40.82]	81 [36.70]
Power Exhaust	44 [19.96]	42 [19.05]
Fresh Air Damper (Manual)	26 [11.79]	21 [9.53]
Fresh Air Damper (Motorized)	43 [19.50]	38 [17.24]
Roof Curb 14"	90 [40.82]	85 [38.60]
Roof Curb 24"	140 [63.50]	135 [61.23]

Capacity Tons [kW]	Corner Weights by Percentage			
	A	B	C	D
7.5 [26.4]	30%	35%	14%	21%
10 [35.2]	33%	27%	17%	23%
12.5 [44.0]	44%	30%	12%	14%

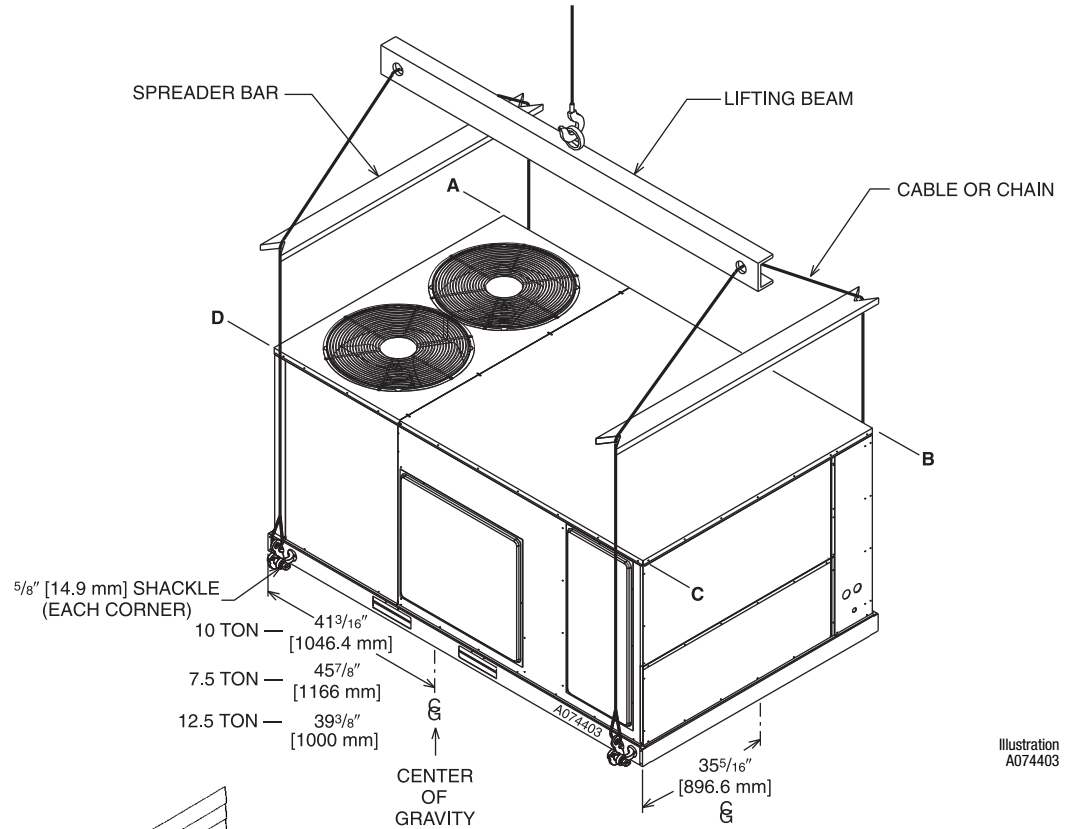

Illustration  
A074403

## CLEARANCES

The following minimum clearances must be observed for proper unit performance and serviceability.

Recommended Clearance In. [mm]	Location
48 [1219]	A - Front
18 [457]	B - Condenser Coil
18 [457]	C - Duct Side
18 [457]	*D - Evaporator End
60 [1524]	E - Above

\*Without Economizer. 48" [1219 mm] With Economizer

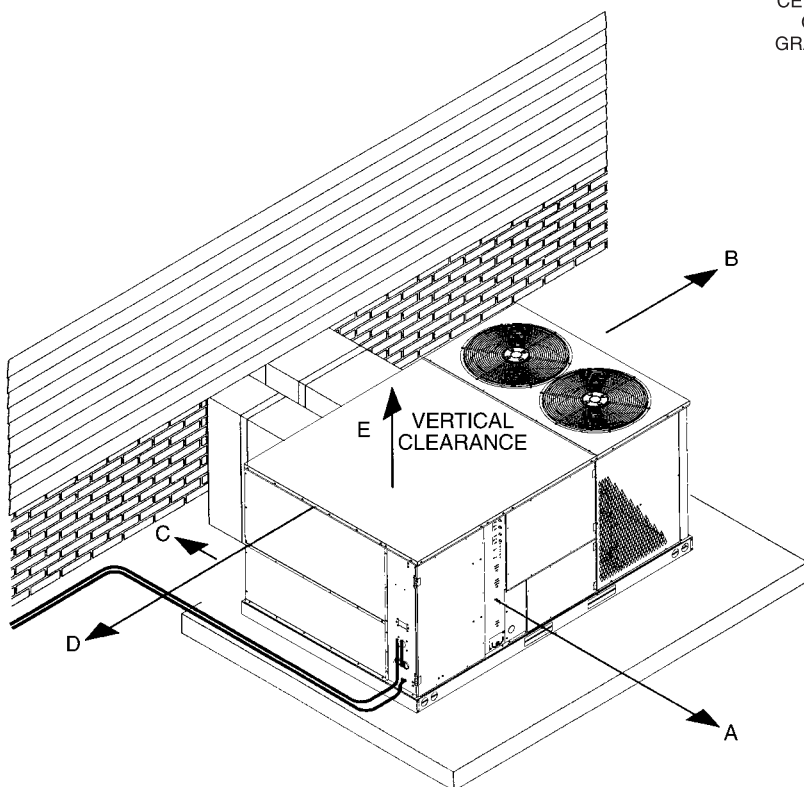

[ ] Designates Metric Conversions

## FIELD INSTALLED ACCESSORY EQUIPMENT

Accessory	Model Number	Shipping Weight Lbs. [kg]	Installed Weight Lbs. [kg]	Factory Installation Available?
Thermostats	See Thermostat Specification Sheet for Details (T11-001)			No
Electric Heaters*—Canadian Use Only.	RXJJ-CC10 (C,D,Y)	46 [20.9]	36 [16.3]	Yes
	RXJJ-CC15 (C,D,Y)	46 [20.9]	36 [16.3]	Yes
	RXJJ-CC20 (C,D,Y)	46 [20.9]	36 [16.3]	Yes
Electric Heaters*—Canadian Use Only.	RXJJ-CC30 (C,D,Y)	47 [21.3]	37 [16.8]	Yes
Electric Heaters*—Canadian Use Only.	RXJJ-CC40 (C,D,Y)	49 [22.2]	39 [17.7]	Yes
Electric Heaters*—Canadian Use Only.	RXJJ-CC50 (C,D,Y)	51 [23.1]	41 [18.6]	Yes
Economizer w/Single Enthalpy	AXRD-PDCM3	90 [40.8]	81 [36.7]	Yes
Economizer w/Single Enthalpy and Smoke Dectector	AXRD-SDCM3	91 [41.3]	82 [37.2]	Yes
Dual Enthalpy Kit	RXR-AV02	1 [0.5]	1 [0.5]	No
Horizontal Economizer w/Single Enthalpy	AXRD-RDCM3	94 [42.6]	89 [40.4]	No
Carbon Dioxide Sensor	RXR-AR02	3 [1.4]	2 [1.0]	No
Power Exhaust	RXR-BFF02 (C,D,Y)	43 [19.5]	38 [17.2]	No
Manual Fresh Air (Left Panel Mounted)	AXRF-KDA1	38 [17.2]	31 [14.0]	No
Manual Fresh Air (Return Panel)	AXRF-JDA1	26 [11.8]	21 [9.5]	No
Motorized Fresh Air (Return Panel)	AXRF-JDB1	43 [19.5]	21 [9.5]	No
Motor Kit for RXRF-KDA1 (Left Panel Mounted)	RXR-AW02	35 [15.19]	27 [17.7]	No
Roofcurb, 14"	RXKG-CAE14	90 [40.8]	85 [38.5]	No
Roofcurb, 24"	RXKG-CAE24	140 [63.5]	135 [61.2]	No
Roofcurb Adapters	RXR-CDCE50	300 [136.1]	290 [131.5]	No
	RXR-CFCE54	325 [147.4]	315 [142.9]	No
	RXR-CFCE56	350 [158.8]	340 [154.2]	No
	RXR-CGCC12	450 [204.1]	410 [186.0]	No
Concentric Diffuser (Step-Down, 18 x 28)	RXRN-AA61	200 [90.7]	185 [83.9]	No
Concentric Diffuser (Step-Down, 18 x 32)	RXRN-AA66	247 [112.0]	227 [103.0]	No
Concentric Diffuser (Flush, 18 x 28)	RXRN-AA71	170 [77.1]	155 [70.3]	No
Concentric Diffuser (Flush, 18 x 32)	RXRN-AA76	176 [79.8]	161 [73.0]	No
Downflow Adapters (Rect. to Round)	RXMC-CD04	15 [6.8]	13 [5.9]	No
Downflow Adapters (Rect. to Rect., 18 x 28)	RXMC-CE05 ①	18 [8.2]	16 [7.3]	No
Downflow Adapters (Rect. to Rect., 18 x 32)	RXMC-CF06 ②	20 [9.1]	18 [8.2]	No
Compressor Time-Delay Relay Kit	RXMD-A04	2 [1.0]	1 [0.5]	No
Low-Ambient Control Kit (1 Per Compressor)	RXRZ-C02	3 [1.4]	2 [1.0]	Yes
Freeze-Stat Kit	RXR-AM01	1 [0.5]	0.5 [0.2]	Yes
Outdoor Coil Louver Kit	AXRX-AAD02A (7 <sup>1</sup> / <sub>2</sub> -12 <sup>1</sup> / <sub>2</sub> Ton)	29 [11.3]	26 [11.8]	Yes
Unwired Convenience Outlet	RXR-AN01	2 [1.0]	1.5 [0.7]	Yes

NOTES: ① Used with RXRN-AA61 and RXRN-AA71 concentric diffusers.  
 ② Used with RXRN-AA66 and RXRN-AA76 concentric diffusers.  
 ③ Please refer to conversion kit index provided with the unit for LP conversion kit.

[ ] Designates Metric Conversions

## THERMOSTATS



**200-Series \***  
Programmable



**300-Series \***  
Deluxe  
Programmable

**400-Series \***  
Special Applications/  
Programmable



**500-Series \***  
Communicating/  
Programmable

Brand	Descriptor (3 Characters)	Series (3 Characters)	System (2 Characters)	Type (2 Characters)	
RHC	-	TST	213	UN	MS
RHC=Rheem	TST=Thermostat	200=Programmable 300=Deluxe Programmable 400=Special Applications/ Programmable 500=Communicating/ Programmable	GE=Gas/Electric UN=Universal (AC/HP/GE) MD=Modulating Furnace DF=Dual Fuel CM=Communicating	SS=Single-Stage MS=Multi-Stage	

\* Photos are representative. Actual models may vary.

For detailed thermostat match-up information,  
see specification sheet form number T11-001.

## ECONOMIZER FOR DOWNFLOW DUCT INSTALLATION

### Use to Select Factory Installed Options Only

**AXRD-PDCM3—Single Enthalpy (Outdoor) and AXRD-SDCM3 Single Enthalpy with Smoke Detector**

**RXXR-AV02—Dual Enthalpy Upgrade Kit**

**RXXR-AR02—Optional Wall-Mounted CO<sub>2</sub> Sensor**

- Features **Honeywell** Controls
- Available Factory Installed or Field Accessory
- Gear Driven Direct Drive Actuator
- Fully Modulating (0-100%)
- Low Leakage Dampers
- Slip-In Design for Easy Installation
- Plug-In Polarized 12-pin Electrical Connections
- Pre-Configured—No Field Adjustments Necessary
- Standard Barometric Relief Damper
- Single Enthalpy with Dual Enthalpy Upgrade Kit Available
- CO<sub>2</sub> Input Sensor Available
- Field Assembled Hood Ships with Economizer
- Economizer Ships Complete for Downflow Duct Application.
- Optional Remote Minimum Position Potentiometer (Honeywell #S963B1128) is Available from Prostock.
- Field Installed Power Exhaust Available
- Prewired for Smoke Detector

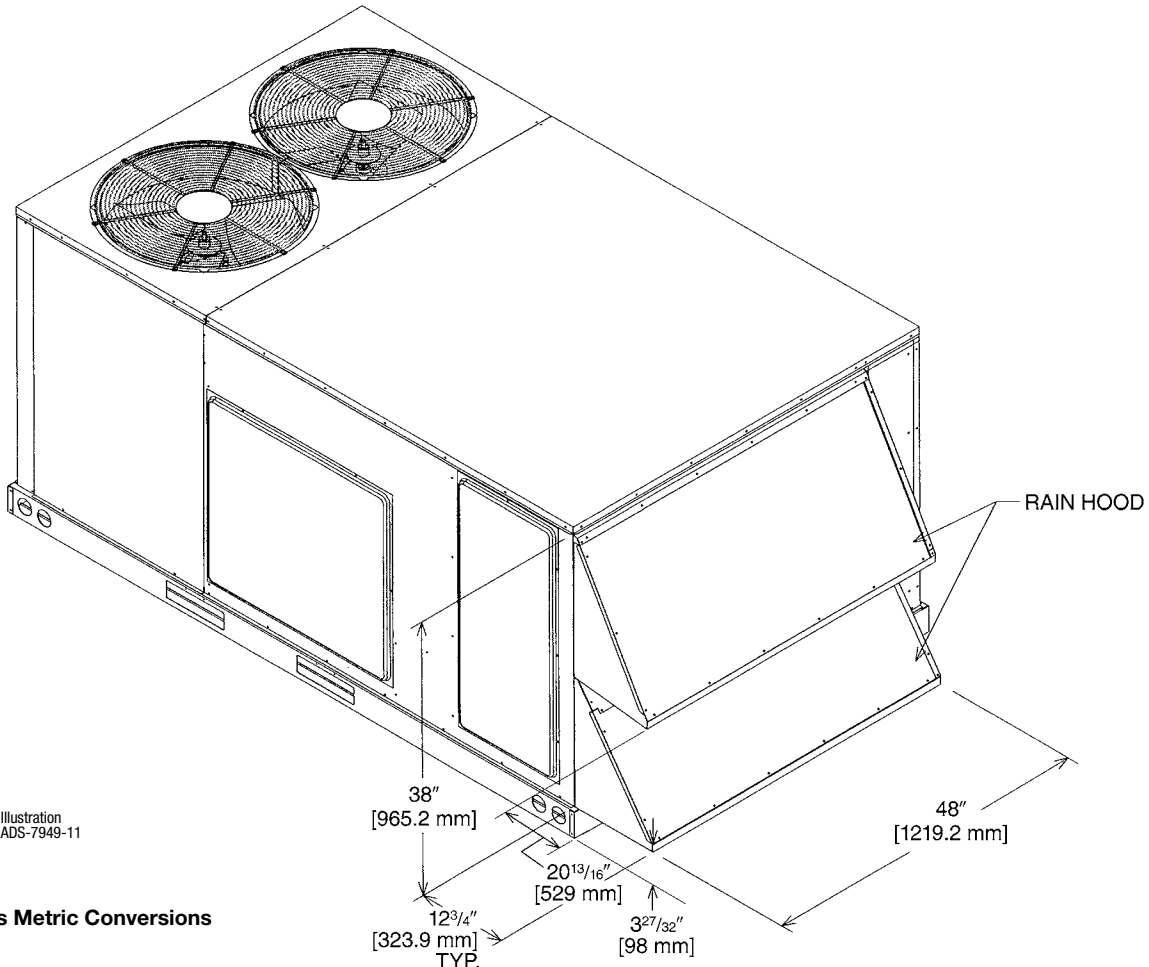
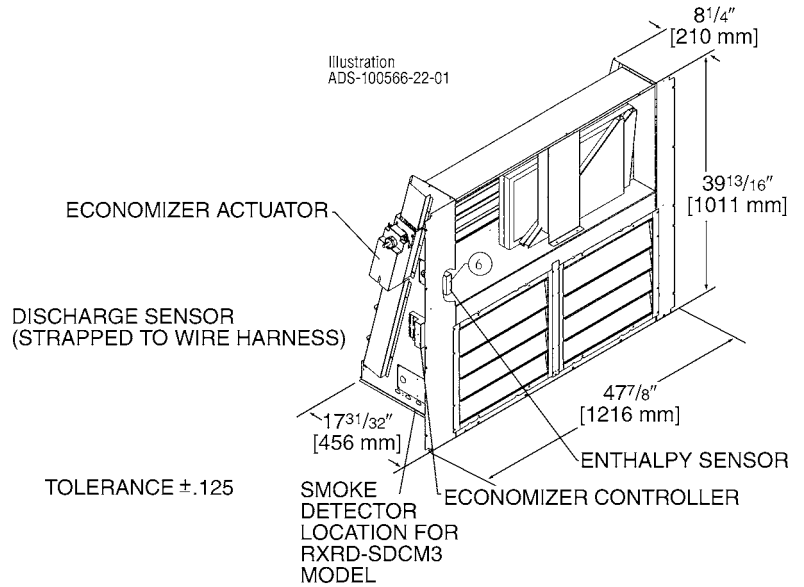

[ ] Designates Metric Conversions

# ECONOMIZER FOR HORIZONTAL DUCT INSTALLATION

Field Installed Only

**AXRD-RDCM3—Single Enthalpy (Outdoor)**

**RXXR-AV02—Dual Enthalpy Upgrade Kit**

**RXXR-AR02—Wall-mounted CO<sub>2</sub> Sensor**

- Features **Honeywell** Controls
- Available as a Field Installed Accessory Only
- Gear Driven Direct Drive Actuator
- Fully Modulating (0-100%)
- Low Leakage Dampers
- Slip-In Design for Easy Installation
- Plug-In Polarized 12-pin Electrical Connections
- Pre-Configured—  
No Field Adjustments Necessary
- Standard Barometric Relief Damper
- Single Enthalpy with Dual Enthalpy Upgrade Kit Available
- CO<sub>2</sub> Input Sensor Available
- Field Assembled Hood Ships with Economizer
- Economizer Ships Complete for Horizontal Duct Application
- Optional Remote Minimum Position Potentiometer (Honeywell #S963B1128) is Available from Prostock
- Field Installed Power Exhaust Available

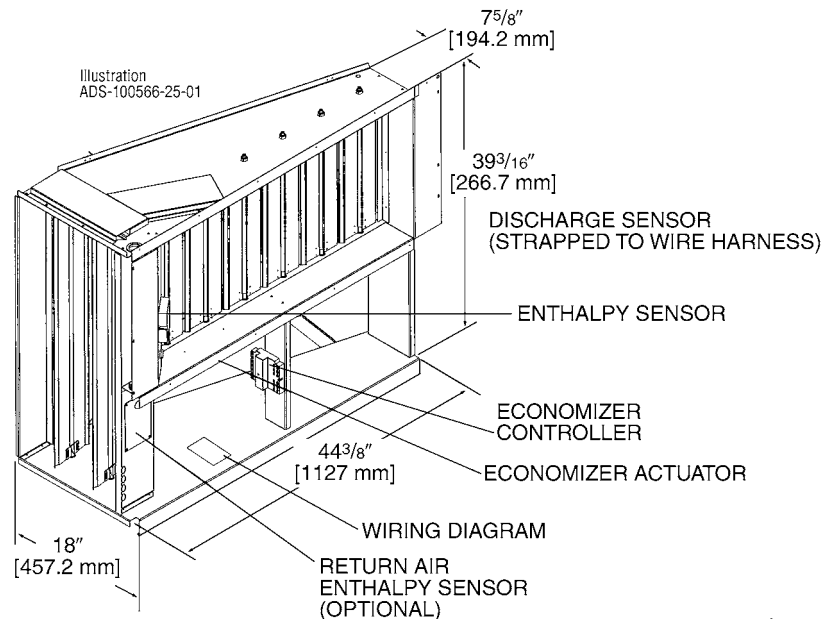

TOLERANCE ± .125

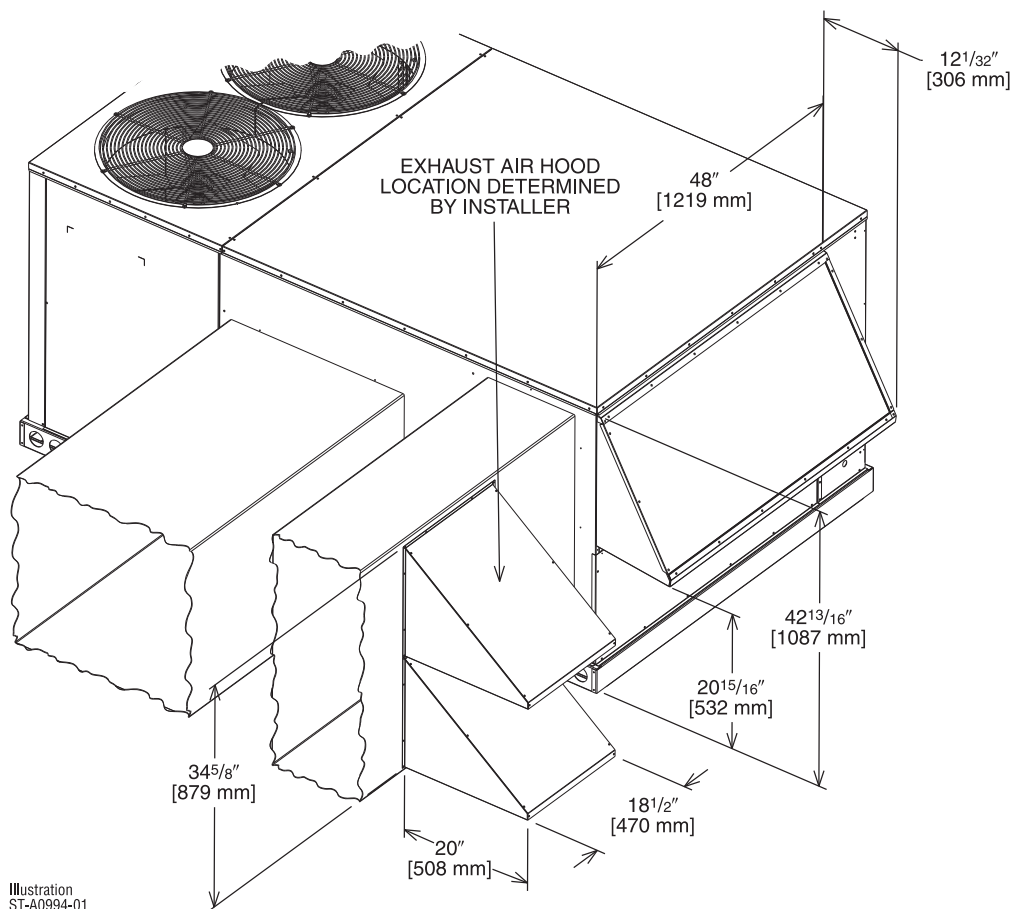

[ ] Designates Metric Conversions

# POWER EXHAUST KIT FOR RXRD-PDCM3(-), RXRD-RDCM3(-), RXRD-SDCM3 ECONOMIZERS

RXRX-BFF02 (C, D, or Y\*)

\*Voltage Code

## VERTICAL AIRFLOW

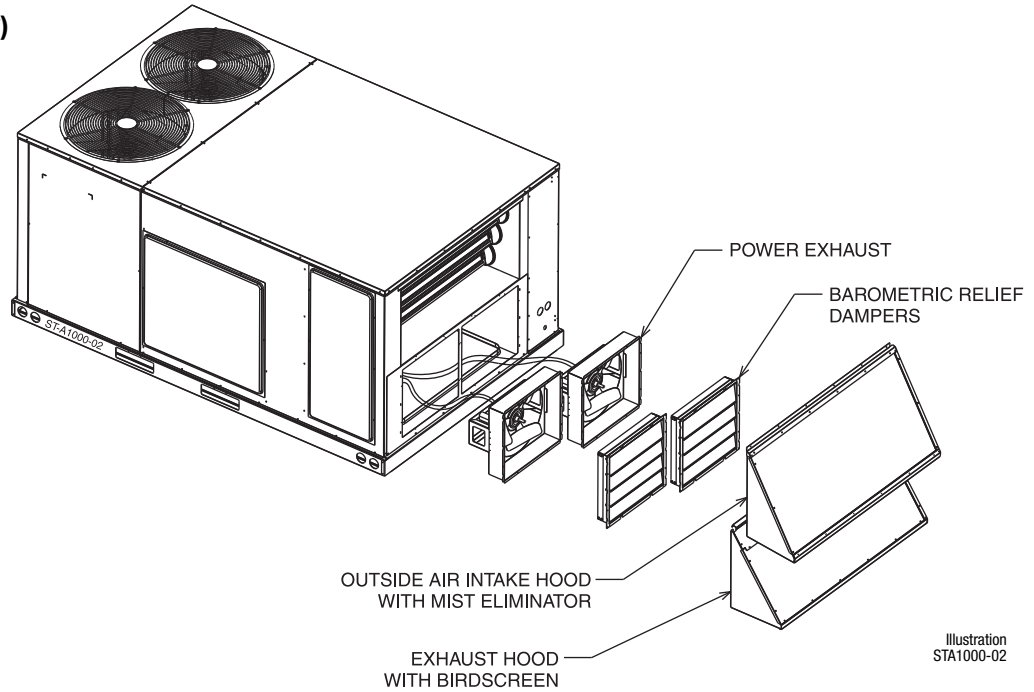

## HORIZONTAL AIRFLOW

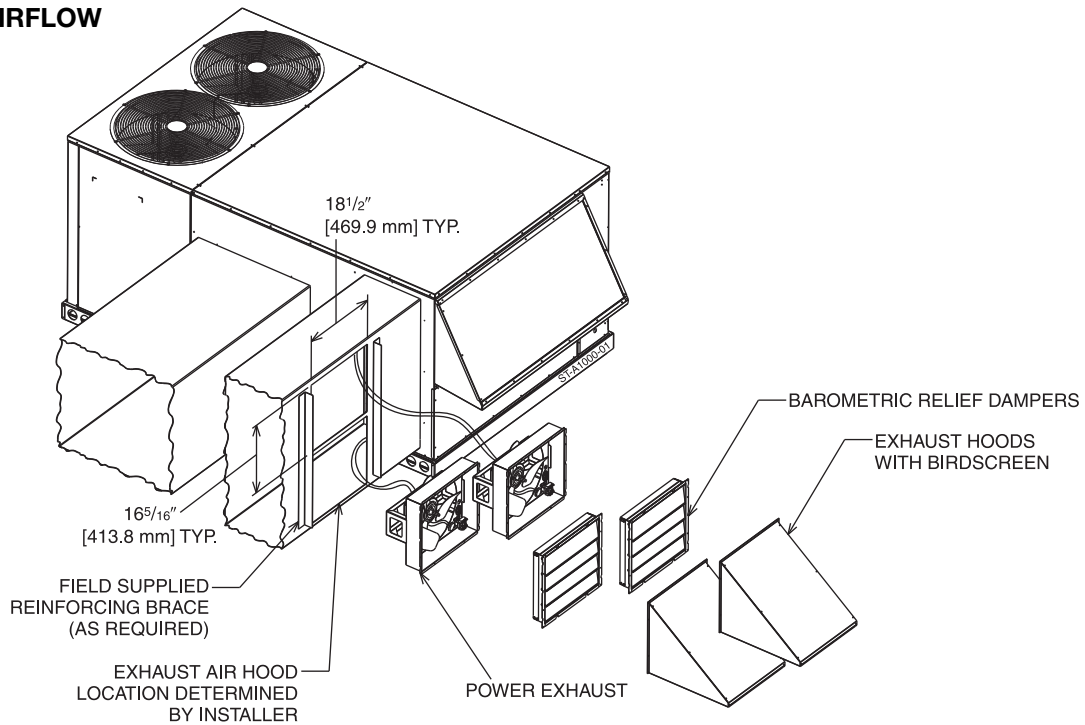

Model No.	No. of Fans	Volts	Phase	HP (ea.)	Low Speed		High Speed ①		FLA (ea.)	LRA (ea.)
					CFM [L/s] ②	RPM	CFM [L/s] ②	RPM		
RXRX-BFF02C	2	208-230	1	0.33	2200 [1038]	1518	2500 [1179]	1670	1.48	3.6
RXRX-BFF02D	2	460	1	0.33	2200 [1038]	1518	2500 [1179]	1670	0.75	1.8
RXRX-BFF02Y	2	575	1	0.33	2200 [1038]	1518	2500 [1179]	1670	0.81	1.5

NOTES: ① Power exhaust is factory set on high speed motor tap.  
② CFM is per fan at 0" w.c. external static pressure.

[ ] Designates Metric Conversions



# FRESH AIR DAMPER

**MOTORIZED DAMPER KIT**  
**RXRX-AW02**  
**(Motor Kit for RXRF-KDA1)**

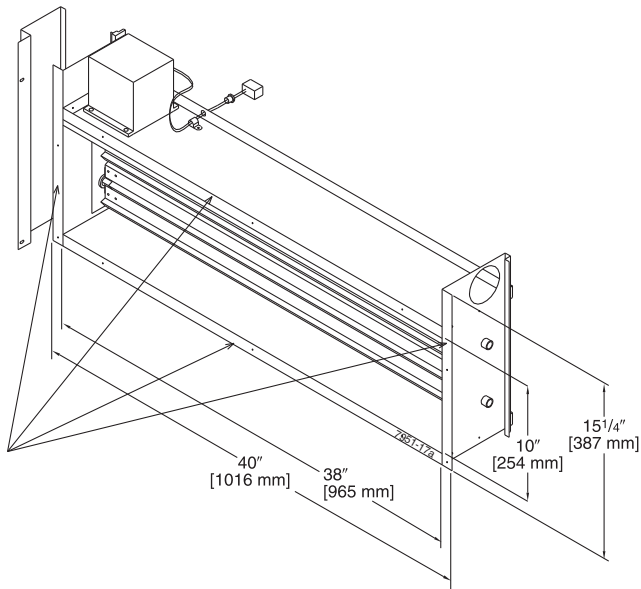

Illustration  
 ST-7951-17

[ ] Designates Metric Conversions

## AXRF-KDA1 (Manual)

**DOWNFLOW OR**  
**HORIZONTAL APPLICATION**

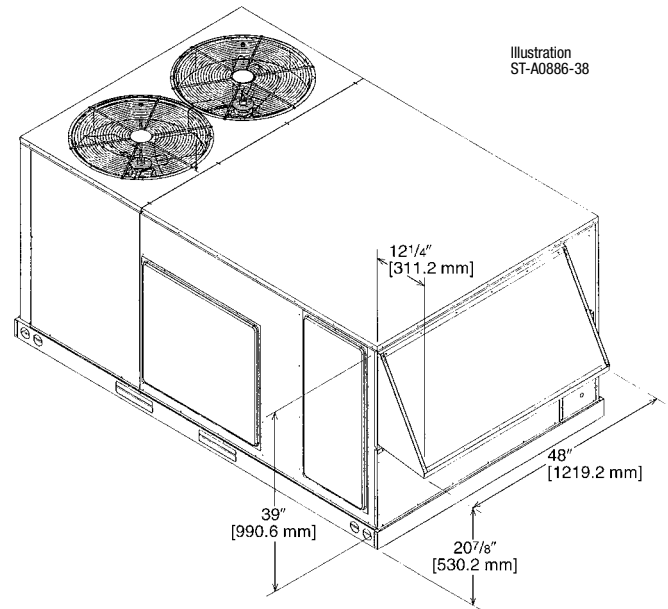

Illustration  
 ST-A0886-38

## FRESH AIR DAMPER (Cont.)

AXRF-JDA1 (Manual)  
AXRF-JDB1 (Motorized)

### DOWNFLOW APPLICATION

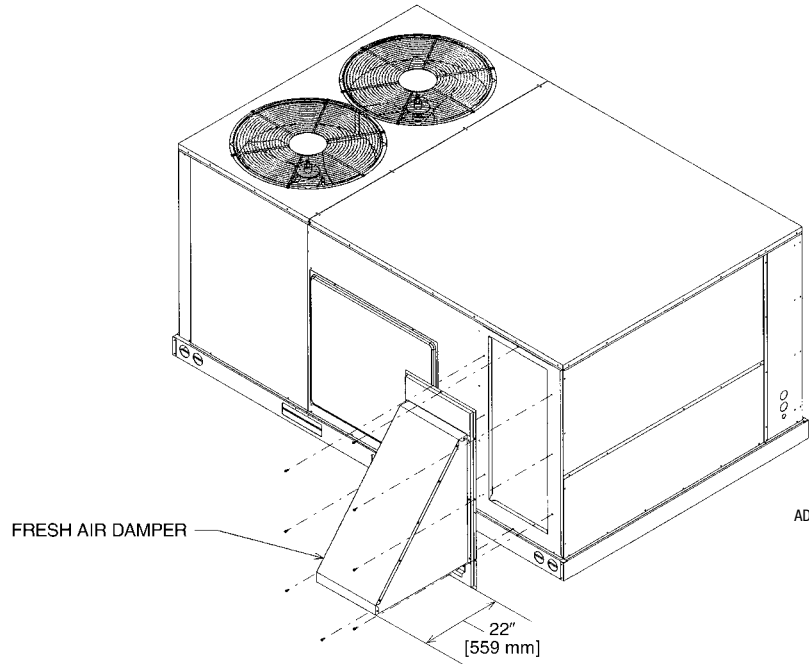
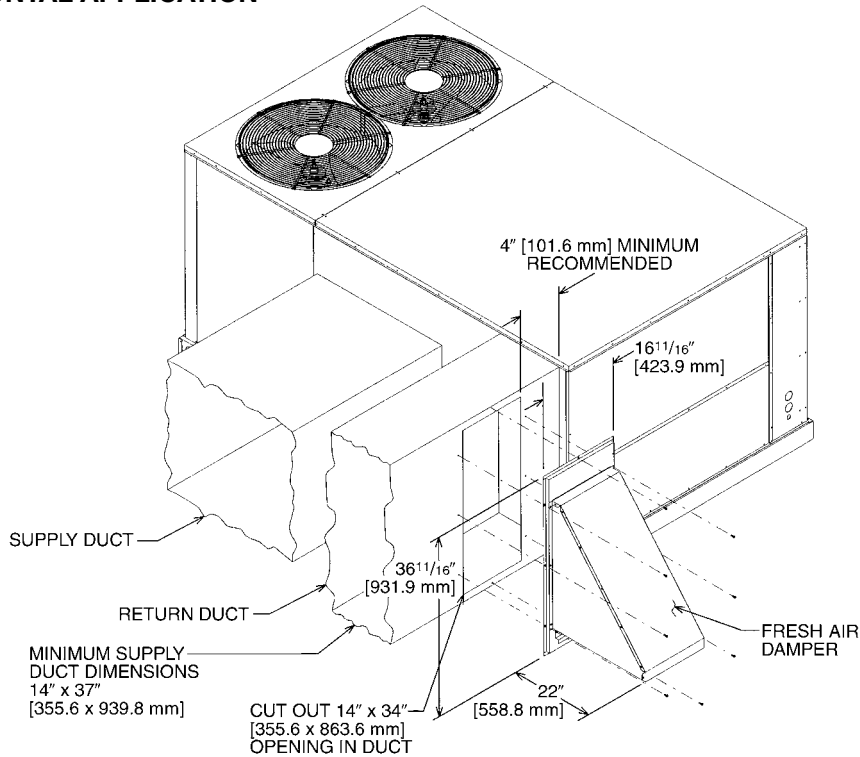

Illustration  
ADS-7937-58

### HORIZONTAL APPLICATION

Illustration  
ST-A0901-01



[ ] Designates Metric Conversions

## ROOFCURBS (Full Perimeter)

- Rheem’s roofcurb design can be utilized on 7.5 & 10 ton [26.4 & 35.2 kW] RLKL-B models.
- Two available heights (14" [356 mm] and 24" [610 mm]) for ALL models.
- Quick assembly corners for simple and fast assembly.
- Opening provided in bottom pan to match the “Thru the Curb” electrical connection opening provided on the unit base pan.
- 1" [25 mm] x 4" [102 mm] Nailer provided.
- Insulating panels not required because of insulated outdoor base pan.
- Sealing gasket (40' [12.2 m]) provided with Roofcurb.
- Packaged for easy field assembly.

Roofcurb Model	Height of Curb
RXKG-CAE14	14" [356 mm]
RXKG-CAE24	24" [610 mm]

## TYPICAL INSTALLATION

Illustration  
ST-A0743-02

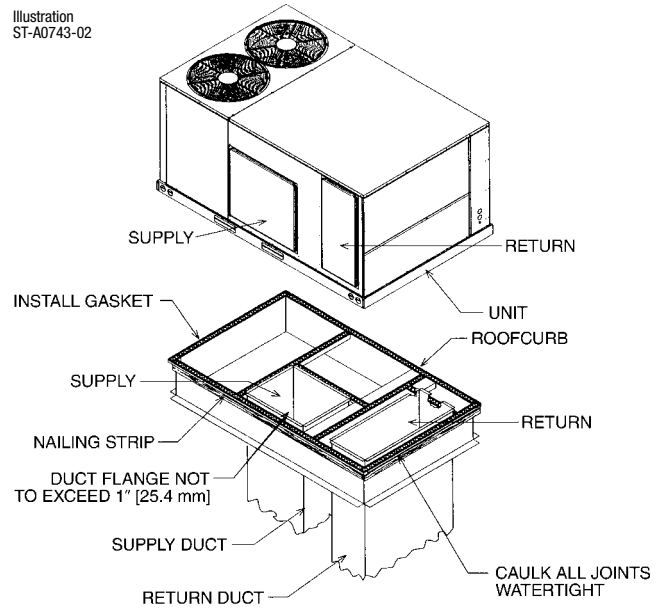

## ROOFCURB INSTALLATION

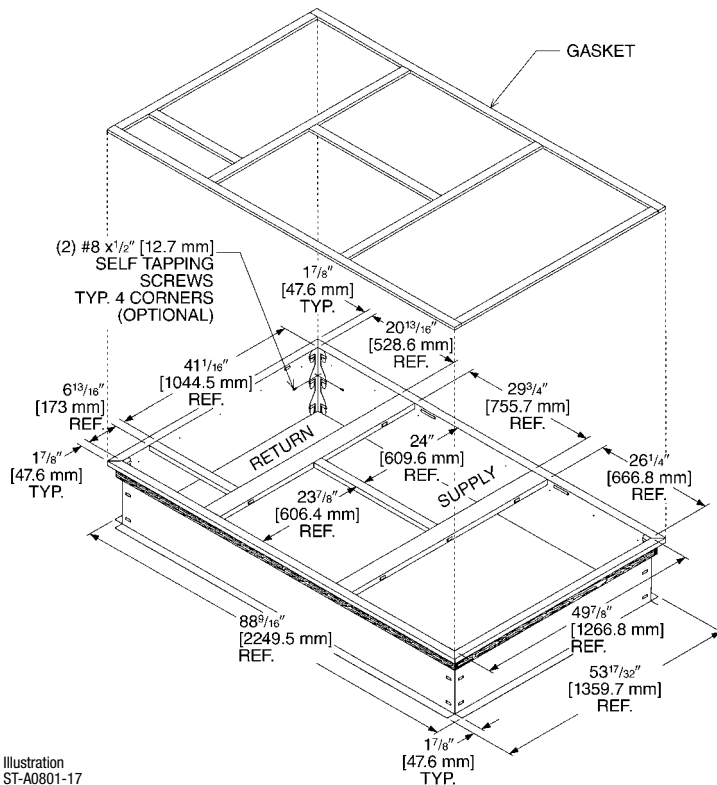
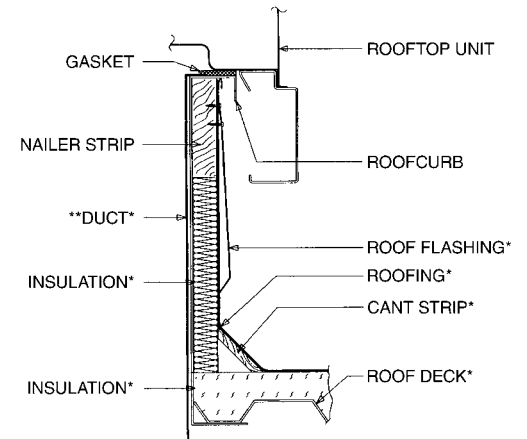

Illustration  
ST-A0801-17



\*BY CONTRACTOR

\*\*FOR INSTALLATION OF DUCT AS SHOWN, USE RECOMMENDED DUCT SIZES FROM ROOFCURB INSTALLATION INSTRUCTIONS. FOR DUCT FLANGE ATTACHMENT TO UNIT, SEE UNIT INSTALLATION INSTRUCTIONS FOR RECOMMENDED DUCT SIZES.

Illustration  
ST-A0743-02

[ ] Designates Metric Conversions

## ROOFCURB ADAPTERS

OLD MODELS	OLD ROOFCURB	ROOFCURB ADAPTER	NEW MODELS (All Share Common Cabinet)
(-)RCF, (-)REF-075/076 (-)RGF-150075, (-)RGF-131076 (-)RGF-201076	RXRK-E50	RXRX-CDCE50	(R)LKL-B090 (R)LKL-B120 (R)LKL-B151
(-)RGF-200075 (-)RGG, (-)REG, (-)RCG-075 (-)RGF, (-)REF, (-)RCF-085 (-)RGF, (-)REF, (-)RCF-100 (-)RGG, (-)REG, (-)RCG-100	RXRK-E54	RXRX-CFCE54	
(-)RGF, (-)REF, (-)RCF-125	RXRK-E56	RXRX-CFCE56	
(-)PDC-075 (-)PDC-100/101	RXPK-C12	RXRX-CGCC12	

NOTE: Ductwork modifications may be necessary if the capacity and/or indoor airflow rate of replacement unit is not equivalent to that of the unit being replaced.  
RLKL- B090, B120 and B151 on same roofcurb as the RLKB- A090, A120 and A150, RLMB- A090, A120 and A150, RLNB- A090 and A120.

# ROOFCURB ADAPTERS (Cont.)

RXRX-CDCE50

Illustration  
ADS-7952-02  
Sheet 2

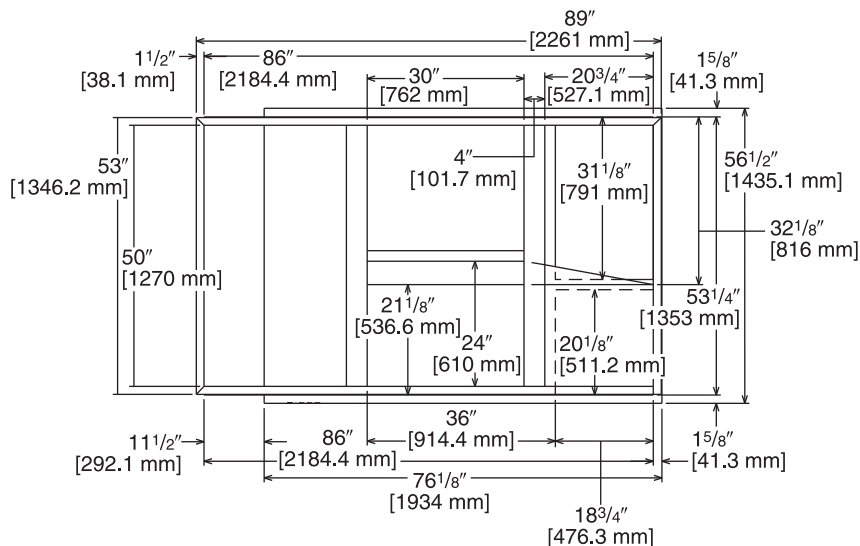

TOP VIEW

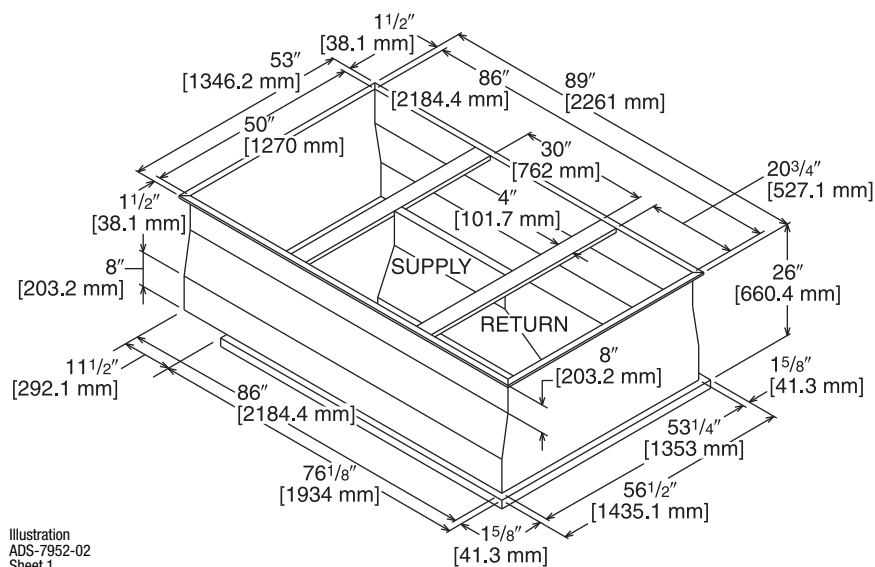

Illustration  
ADS-7952-02  
Sheet 1

[ ] Designates Metric Conversions

# ROOFCURB ADAPTERS (Cont.)

RXXR-CFCE54

Illustration  
ADS-7952-01  
Sheet 2

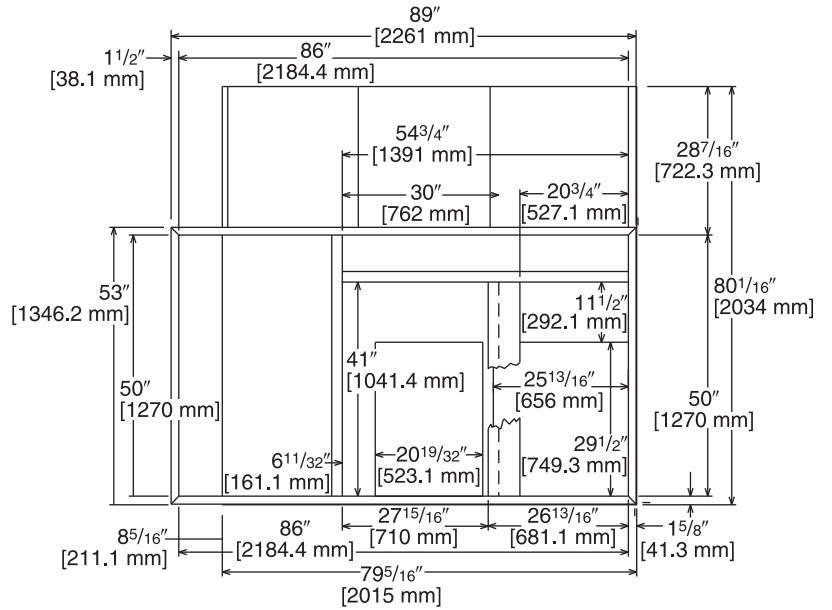

**TOP VIEW**

Illustration  
ADS-7952-01  
Sheet 1

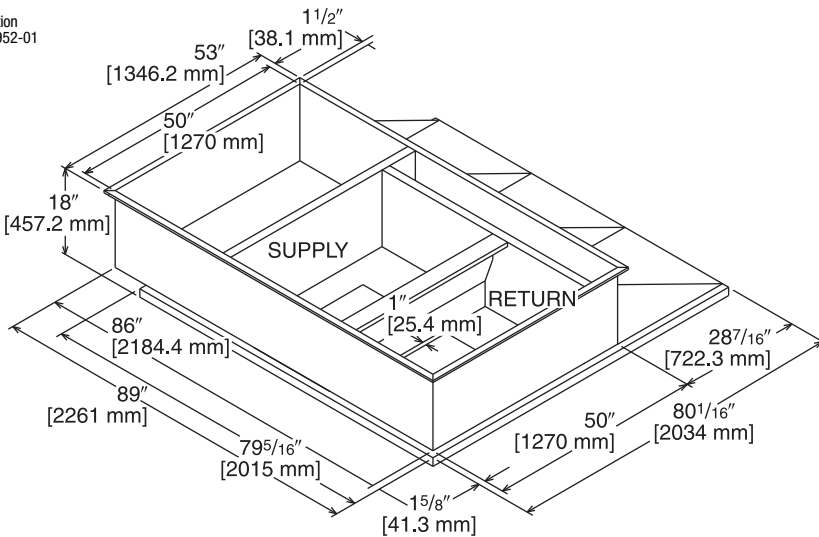

[ ] Designates Metric Conversions

# ROOFCURB ADAPTERS (Cont.)

RXRX-CFCE56

Illustration  
ADS-7952-03  
Sheet 2

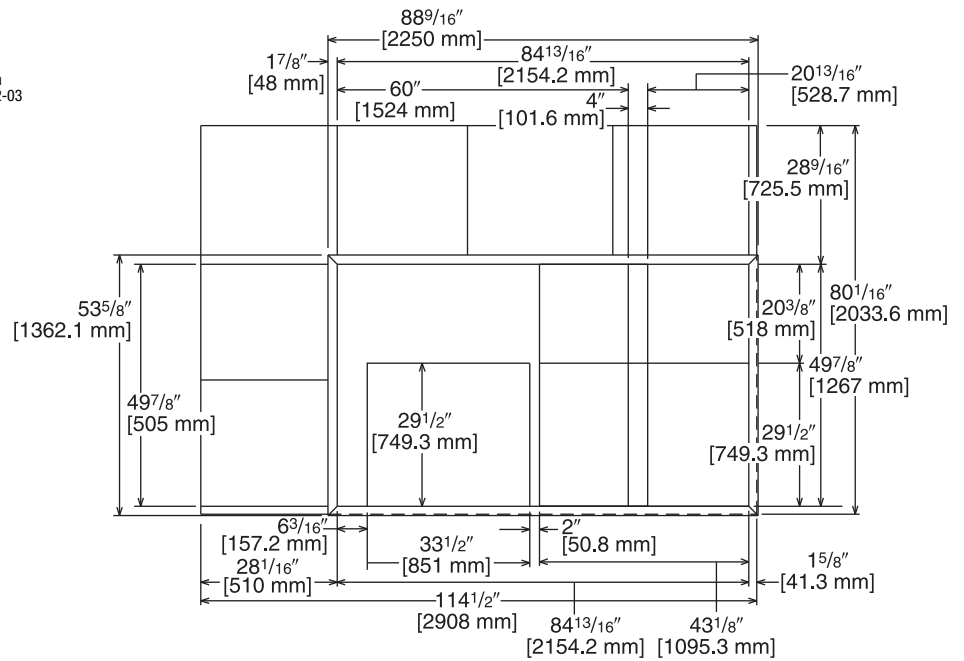

**TOP VIEW**

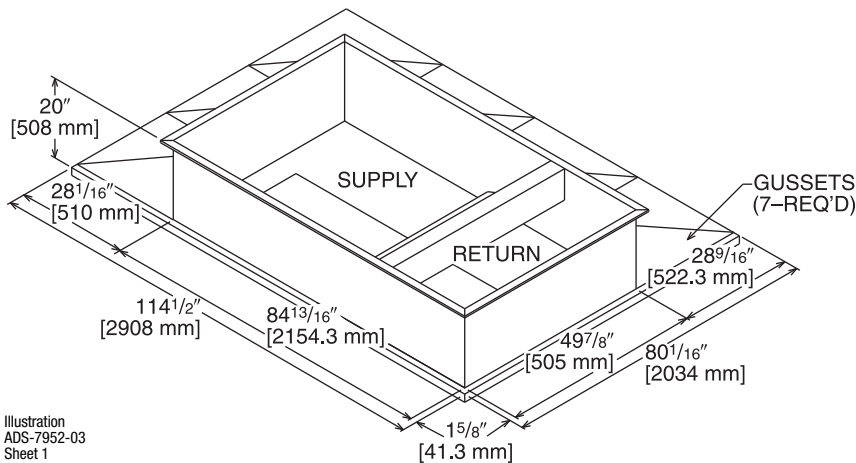

Illustration  
ADS-7952-03  
Sheet 1

[ ] Designates Metric Conversions

# ROOFCURB ADAPTERS (Cont.)

RXRX-CGCC12

Illustration  
ADS-7952-04  
Sheet 2

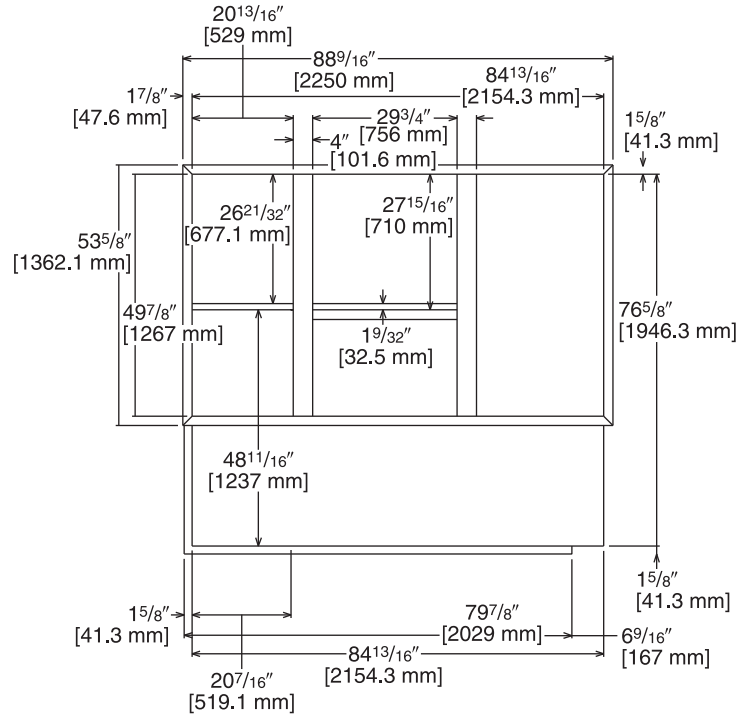

**TOP VIEW**

Illustration  
ADS-7952-04  
Sheet 1

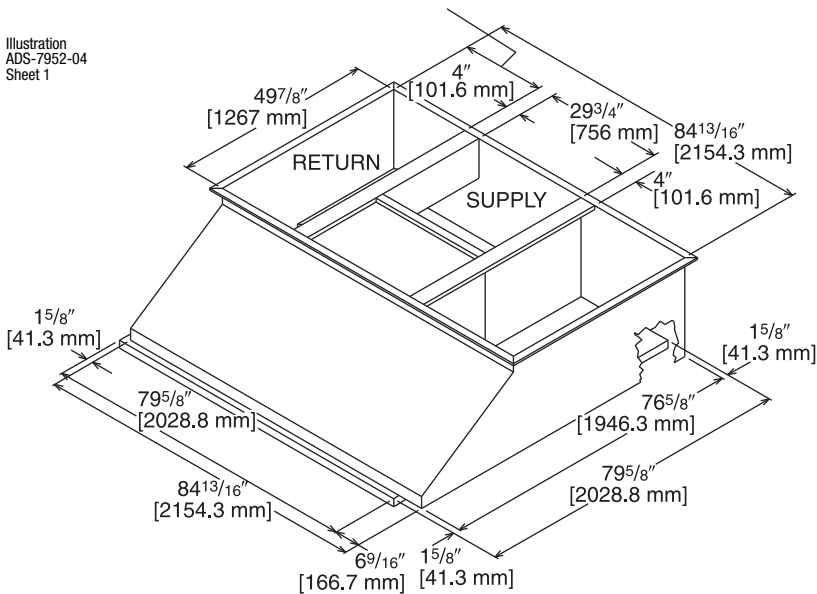

[ ] Designates Metric Conversions



# CONCENTRIC DIFFUSER APPLICATION

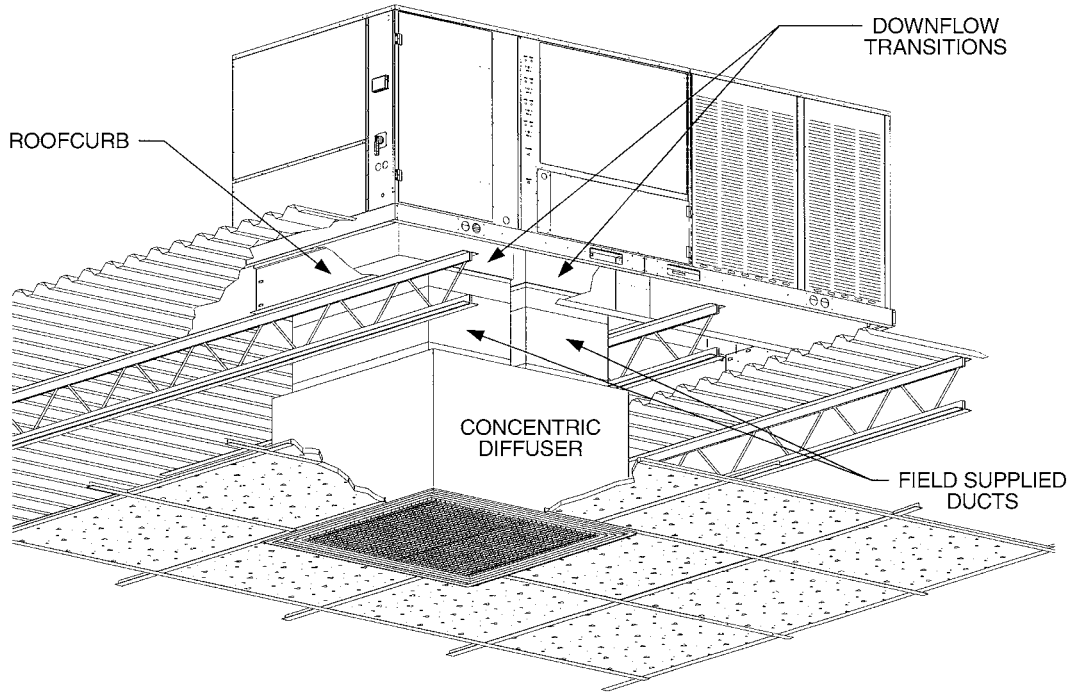

Illustration  
ST-A0840-02

## DOWNFLOW TRANSITION DRAWINGS

### RXMC-CE05

- Used with RXRN-AA61 or RXRN-AA71 Concentric Diffusers.

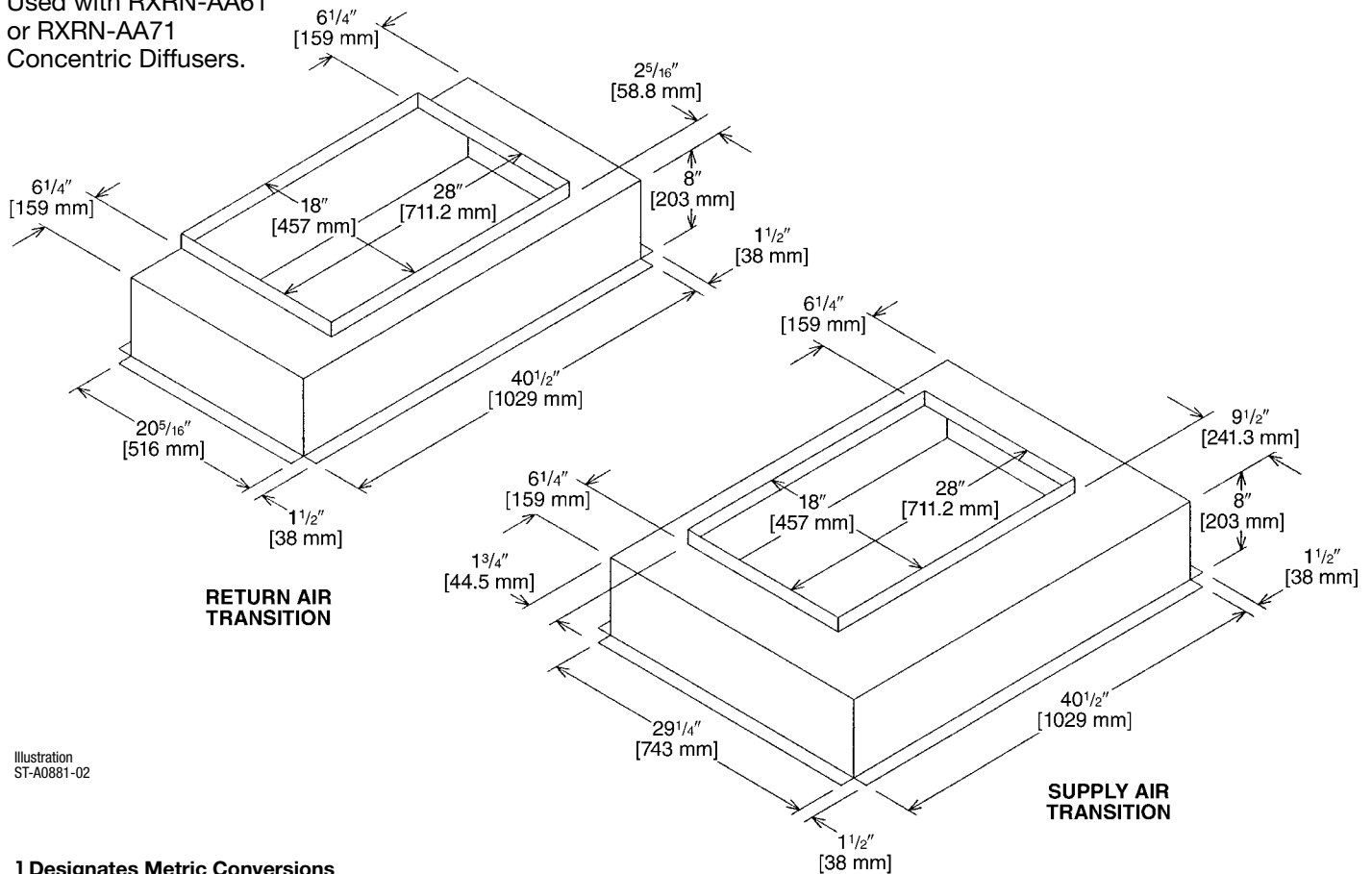

Illustration  
ST-A0881-02

[ ] Designates Metric Conversions

## DOWNFLOW TRANSITION DRAWINGS (Cont.)

### RXMC-CF06

- Used with RXRN-AA66 or RXRN-AA76 Concentric Diffusers.

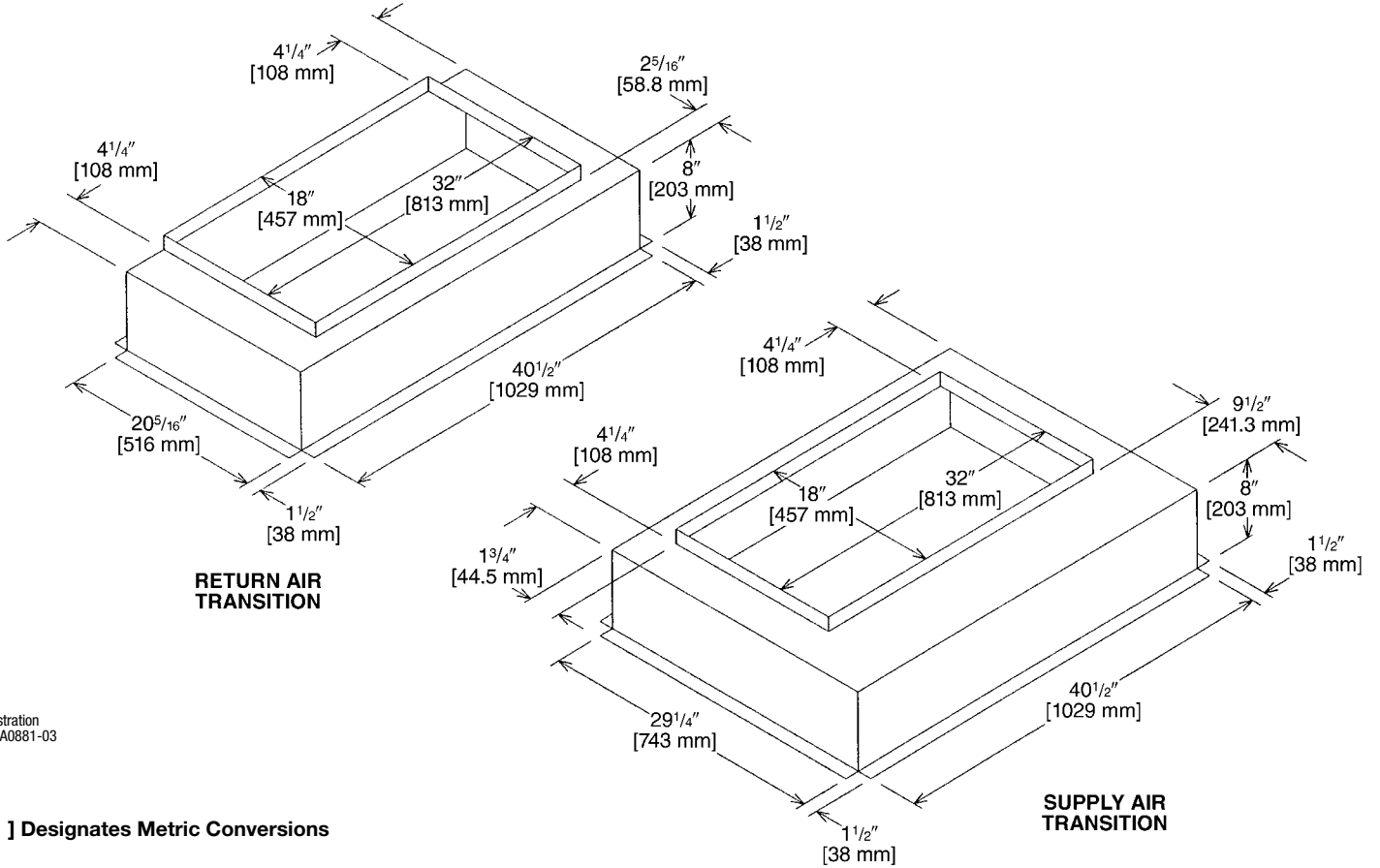

Illustration  
ST-A0881-03

[ ] Designates Metric Conversions

## DOWNFLOW TRANSITION DRAWINGS (Cont.)

### RXMC-CD04

- Used with RXRN-FA65  
 or RXRN-FA75  
 Concentric Diffusers.

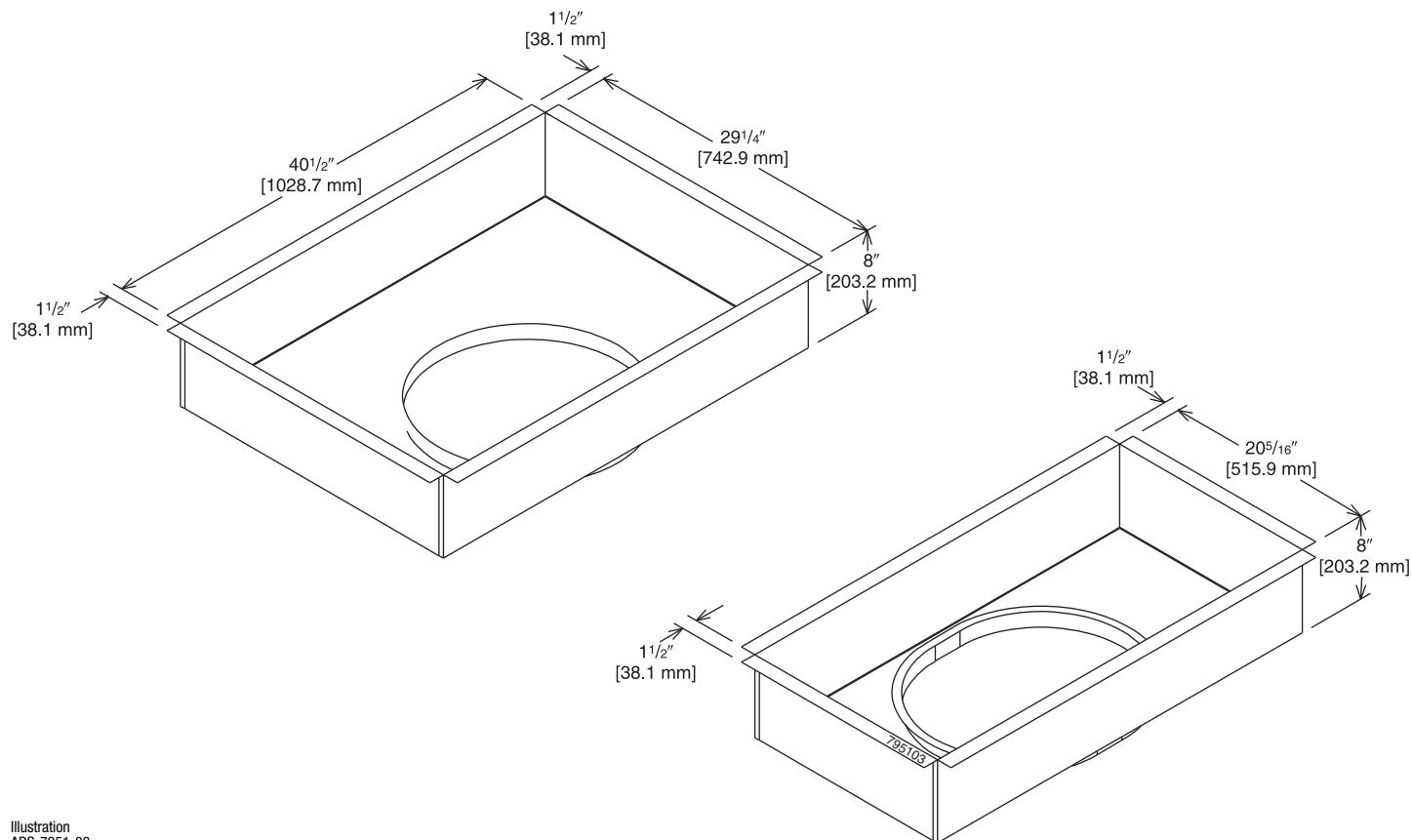

Illustration  
 ADS-7951-03

[ ] Designates Metric Conversions

## CONCENTRIC DIFFUSER—STEP DOWN

RXRN-FA65 (7.5 & 8.5 Ton [26.4 & 29.9 kW] Models)

For Use With Downflow Transition (RXMC-CD04) and 20" [508 mm] Round Supply and Return Ducts

- All aluminum diffuser with aluminum return air eggcrate.
- Built-in anti-sweat gasket.
- Molded fiberglass supports.
- Built-in hanging supports.
- Diffuser box constructed of sheetmetal insulated with 1" [25.4 mm] 1.5 lbs. [.7 kg] duct liner.

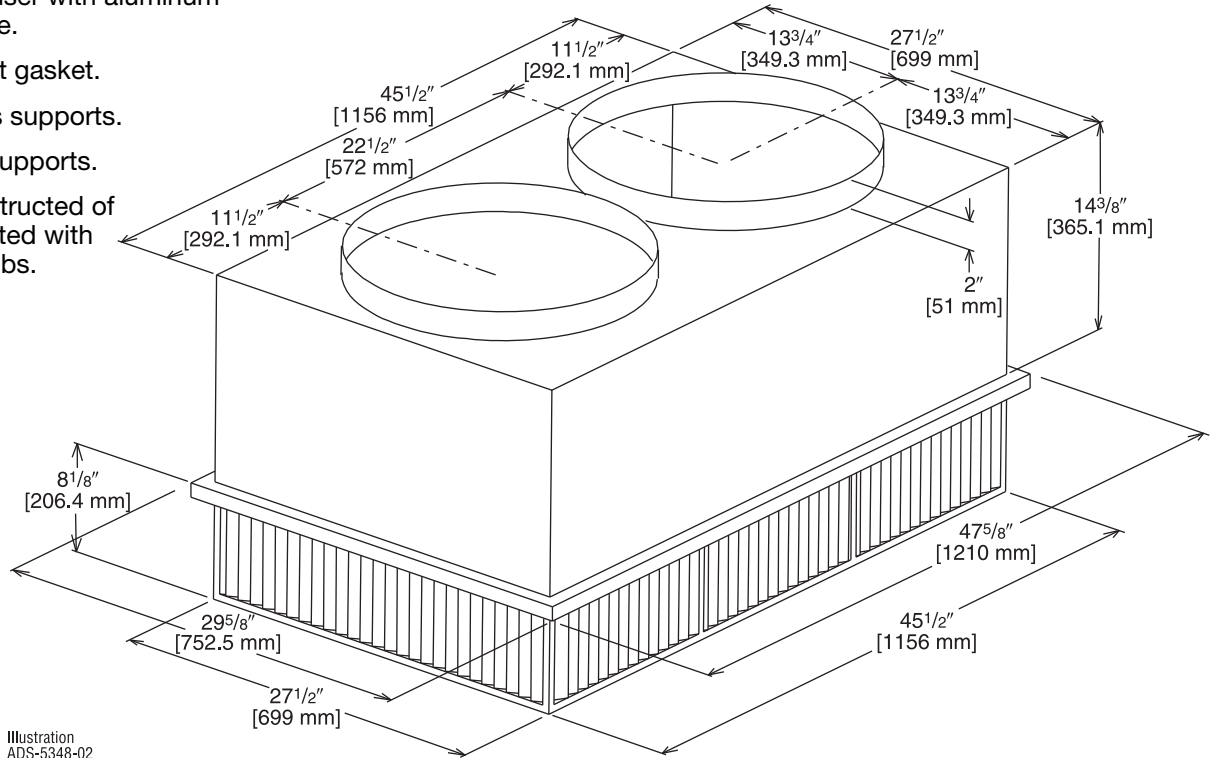

Illustration  
ADS-5348-02

## ENGINEERING DATA<sup>①</sup>

Model No.	Flow Rate CFM [L/s]	Static Pressure in. w.c. [kPa]	Throw <sup>②</sup> <sup>③</sup> Feet [m]	Neck Velocity fpm [m/s]	Noise Level <sup>④</sup> (dbA)
RXRN-FA65	2600 [1227]	0.17 [0.042]	24-29 [7.3-8.8]	669 [3.4]	20
	2800 [1321]	0.20 [0.050]	25-30 [7.6-9.1]	720 [3.7]	25
	3000 [1416]	0.25 [0.062]	27-33 [8.2-10.1]	772 [3.9]	25
	3200 [1510]	0.31 [0.077]	28-35 [8.5-10.7]	823 [4.2]	25
	3400 [1604]	0.37 [0.092]	30-37 [9.1-11.3]	874 [4.4]	30

NOTES: <sup>①</sup> All data is based on the air diffusion council guidelines.

<sup>②</sup> Throw data is based on 75 FPM Terminal Velocities using isothermal air.

<sup>③</sup> Throw is based on diffuser blades being directed in a straight pattern.

<sup>④</sup> Actual noise levels may vary due to duct design and do not include transmitted unit noise.

Adequate duct attenuation must be provided to reduce sound output from the unit.

[ ] Designates Metric Conversions

# CONCENTRIC DIFFUSER—STEP DOWN 18" x 28" [457.2 x 711.2 mm]

RXRN-AA61 (8.5 & 10 Ton [29.9 kW & 35.2] Models)

For Use With Downflow Transition (RXMC-CE05)  
and 18" x 28" [457.2 x 711.2 mm]  
Supply and Return Ducts

- All aluminum diffuser with aluminum return air eggcrate.
- Built-in anti-sweat gasket.
- Molded fiberglass supports.
- Built-in hanging supports.
- Diffuser box constructed of sheetmetal insulated with 1" [25.4 mm] 1.5 lbs. [.7 kg] duct liner.
- Double deflection diffuser with the blades secured by spring steel.

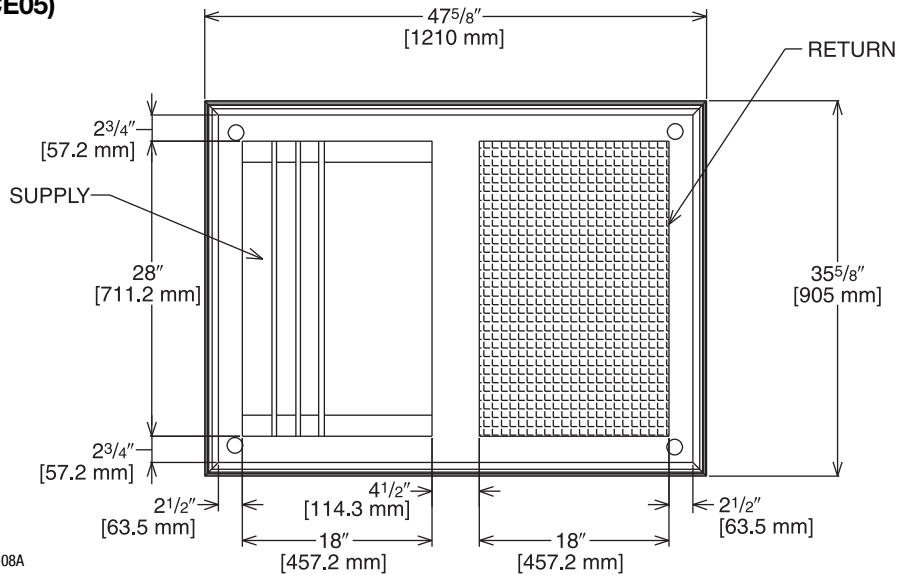

Illustration  
ADS-7951-08A

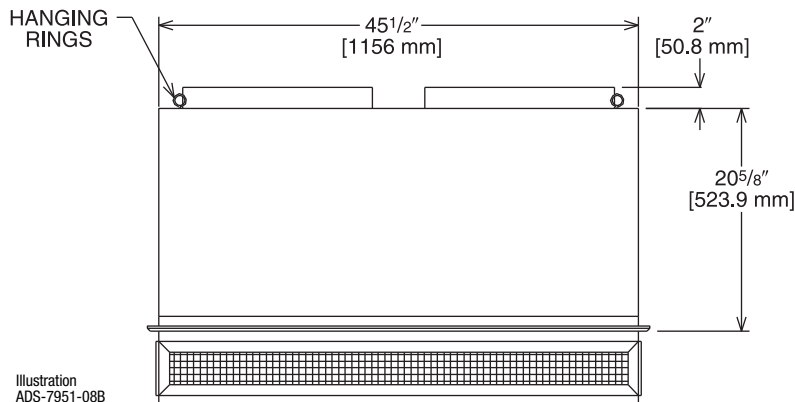

Illustration  
ADS-7951-08B

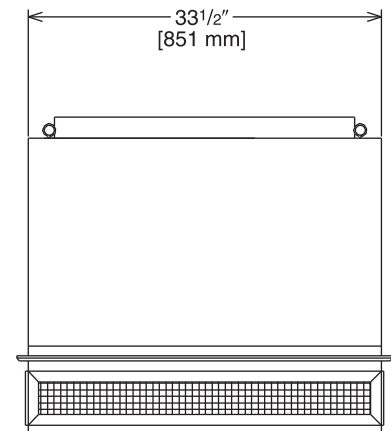

Illustration  
ADS-7951-08C

## ENGINEERING DATA<sup>①</sup>

Model No.	Flow Rate CFM [L/s]	Static Pressure in w.c. [kPa]	Throw <sup>② ③</sup> Feet [m]	Neck Velocity fpm [m/s]	Noise Level <sup>④</sup> (dba)
RXRN-AA61	3600 [1699]	0.17 [0.042]	25-33 [7.6-10.1]	851 [4.3]	30
	3800 [1793]	0.18 [0.045]	27-35 [8.2-10.7]	898 [4.6]	30
	4000 [1888]	0.21 [0.052]	29-37 [8.8-11.3]	946 [4.8]	30
	4200 [1982]	0.24 [0.060]	32-40 [9.8-12.2]	993 [5.0]	30
	4400 [2076]	0.27 [0.067]	34-42 [10.4-12.8]	1040 [5.3]	30

NOTES: ① All data is based on the air diffusion council guidelines.

② Throw data is based on 75 FPM Terminal Velocities using isothermal air.

③ Throw is based on diffuser blades being directed in a straight pattern.

④ Actual noise levels may vary due to duct design and do not include transmitted unit noise.  
Adequate duct attenuation must be provided to reduce sound output from the unit.

[ ] Designates Metric Conversions

# FLUSH MOUNT CONCENTRIC DIFFUSER—FLUSH

RXRN-FA75 (7.5 & 8.5 Ton [26.4 & 29.9 kW] Models)

For Use With Downflow Transition (RXMC-CD04)  
and 20" [508 mm] Round Supply and Return Ducts

- All aluminum diffuser with aluminum return air eggcrate.
- Built-in anti-sweat gasket.
- Molded fiberglass supports.
- Built-in hanging supports.
- Diffuser box constructed of sheetmetal insulated with 1" [25.4 mm] 1.5 lbs. [.7 kg] duct liner.

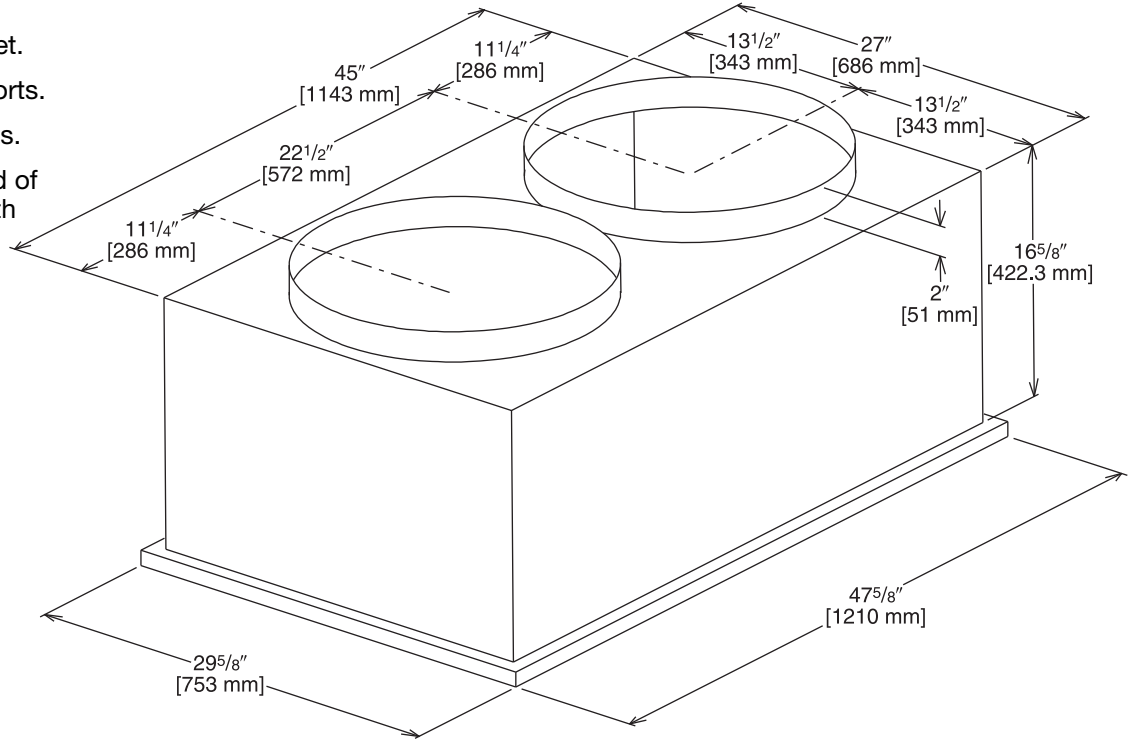

Illustration  
ADS-5348-04

## ENGINEERING DATA<sup>①</sup>

Model No.	Flow Rate CFM [L/s]	Static Pressure in. w.c. [kPa]	Throw <sup>② ③</sup> Feet [m]	Neck Velocity fpm [m/s]	Noise Level <sup>④</sup> (dbA)
RXRN-FA75	2600 [1227]	.17 [0.042]	19-24 [5.8-7.3]	663 [3.4]	30
	2800 [1321]	.20 [0.050]	20-28 [6.1-8.5]	714 [3.6]	35
	3000 [1416]	.25 [0.062]	21-29 [6.4-8.8]	765 [3.9]	35
	3200 [1510]	.31 [0.077]	22-29 [6.7-8.8]	816 [4.1]	40
	3400 [1604]	.37 [0.092]	22-30 [6.7-9.1]	867 [4.4]	40

- NOTES: ① All data is based on the air diffusion council guidelines.  
 ② Throw data is based on 75 FPM Terminal Velocities using isothermal air.  
 ③ Throw is based on diffuser blades being directed in a straight pattern.  
 ④ Actual noise levels may vary due to duct design and do not include transmitted unit noise.  
 Adequate duct attenuation must be provided to reduce sound output from the unit.

[ ] Designates Metric Conversions

# CONCENTRIC DIFFUSER—FLUSH and 18" x 28" [457.2 x 711.2 mm]

RXRN-AA71 (8.5 & 10 Ton [29.9 & 35.2] Models)

For Use With Downflow Transition (RXMC-CE05)  
and 18" x 28" [457.2 x 711.2 mm]  
Supply and Return Ducts

- All aluminum diffuser with aluminum return air eggcrate.
- Built-in anti-sweat gasket.
- Molded fiberglass supports.
- Built-in hanging supports.
- Diffuser box constructed of sheetmetal insulated with 1" [25.4 mm] 1.5 lbs. [.7 kg] duct liner.

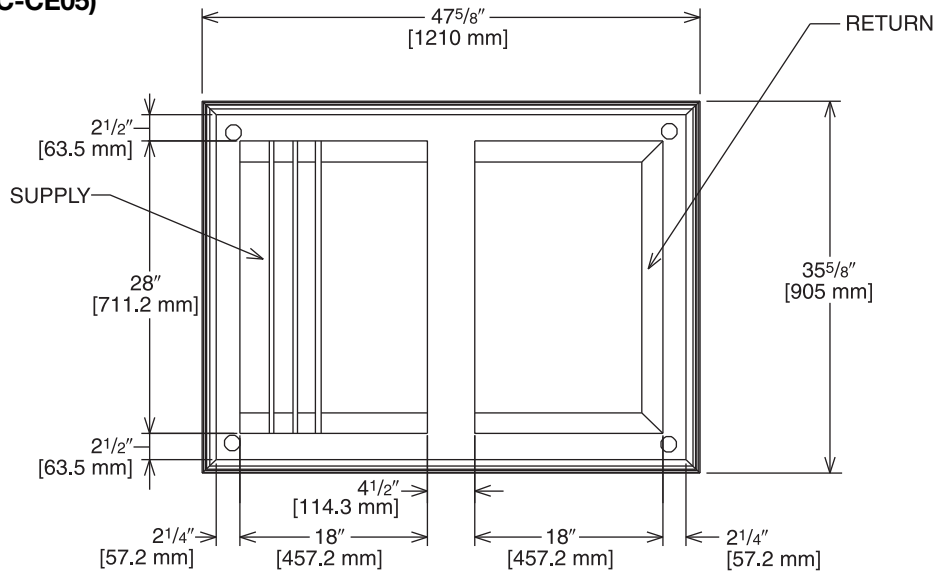

Illustration  
ADS-7951-06A

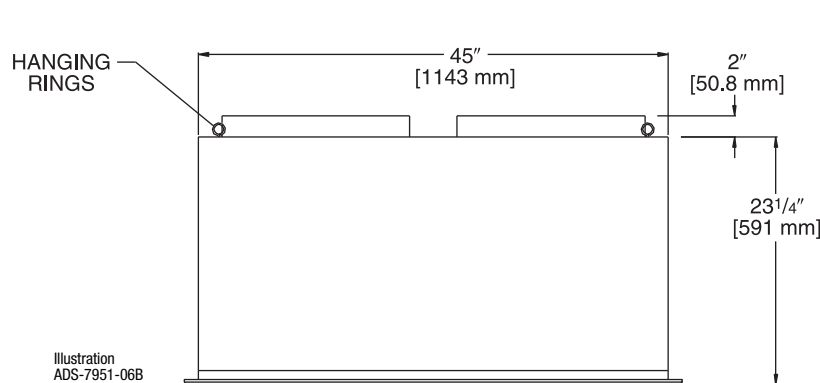

Illustration  
ADS-7951-06B

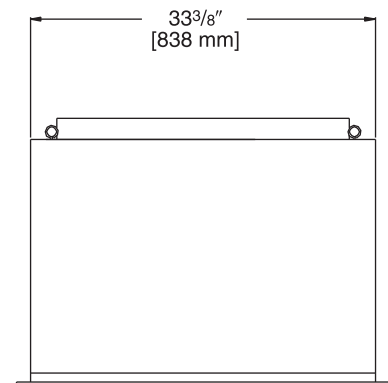

Illustration  
ADS-7951-06C

## ENGINEERING DATA<sup>①</sup>

Model No.	Flow Rate CFM [L/s]	Static Pressure in w.c. [kPa]	Throw <sup>② ③</sup> Feet [m]	Neck Velocity fpm [m/s]	Noise Level <sup>④</sup> (dbA)
RXRN-AA71	3600 [1699]	0.17 [0.042]	22-29 [6.7-8.8]	844 [4.3]	35
	3800 [1793]	0.18 [0.045]	22-30 [6.7-9.1]	891 [4.5]	40
	4000 [1888]	0.21 [0.052]	24-33 [7.3-10.1]	938 [4.8]	40
	4200 [1982]	0.24 [0.060]	26-35 [7.9-10.7]	985 [5.0]	40
	4400 [2076]	0.27 [0.067]	28-37 [8.5-11.3]	1032 [5.2]	40

NOTES: ① All data is based on the air diffusion council guidelines.

② Throw data is based on 75 FPM Terminal Velocities using isothermal air.

③ Throw is based on diffuser blades being directed in a straight pattern.

④ Actual noise levels may vary due to duct design and do not include transmitted unit noise. Adequate duct attenuation must be provided to reduce sound output from the unit.

[ ] Designates Metric Conversions

## General

Units shall be convertible airflow. Operating range for units with electromechanical controls shall be between 125°F (51.7°C) and 50°F (4.4°C). Cooling performance shall be rated in accordance with DOE and/or AHRI testing procedures. All units shall be factory assembled, internally wired, fully charged with R-410A, and 100 percent run-tested before leaving the factory. Wiring internal to the unit shall be colored and numbered for simplified identification. Units shall be UL listed and labeled, classified in accordance to UL 1995/CAN/CSA No. 236-M90 for central cooling air conditioners. Canadian units shall be CUL certified.

## Casing

Unit casing shall be constructed of zinc coated, heavy gauge, galvanized steel. Exterior surfaces shall be cleaned, phosphatized, and finished with a weather-resistant baked enamel finish. Unit's surface shall be tested 1000 hours in a salt spray test in compliance with ASTM B117. Cabinet construction shall allow for all maintenance on one side of the unit. All exposed vertical panels and top covers in the indoor air section shall be insulated with a cleanable foil faced, fire retardant permanent, odorless glass fiber material and secured with adhesive and mechanical fasteners. The base of the unit shall be insulated with foil-faced material. All insulation edges shall be either captured or sealed. The unit's base pan shall have no penetrations within the perimeter of the curb other than the raised 1-1/8" [28.58 mm] high downflow supply return openings to provide an added water integrity precaution. The base rails of the unit shall have provisions for forklift and crane lifting, with forklift capabilities on three sides of the unit.

## Unit Top

The indoor top cover shall be one-piece construction, it shall not be double-hemmed and gasket-sealed.

## Filters

Two inch [50.8 mm], throwaway filters shall be standard on all units.

## Compressors

Units shall have direct-drive, hermetic, scroll type compressors with centrifugal type oil pumps. Motor shall be suction gas-cooled and shall have a voltage utilization range of plus or minus 10 percent of unit nameplate voltage. Internal overloads shall be provided with the scroll compressors. The compressor shall have external isolation to minimize noise.

## Refrigerant Circuits

Each refrigerant circuit shall have orifice refrigerant control expansion device or TXV. Service pressure ports, shall be factory-installed as standard.

## Evaporator Coils and MicroChannel Condenser Coils

Evaporator shall be internally finned, 3/8" [9.53 mm] copper tubes mechanically bonded to a configured aluminum plate fin shall be standard. Condenser coil shall be MicroChannel. Coils shall be leak tested at the factory to ensure pressure integrity. The evaporator coil and condenser coil shall be leak tested to 200 psig and pressure tested to 450 psig. A sloped condensate drain pan shall be standard and shall be removable.

## Outdoor Fans

The outdoor fans shall be direct-drive statically and dynamically balanced, draw-through in the vertical discharge position. The fan motor shall be permanently lubricated and shall have built-in thermal overload protection.

## Indoor Fans

All 3-phase units offer belt drive, FC centrifugal fans with adjustable motor sheaves. All motors shall be thermally protected. All indoor fan motors meet the U.S. Energy Policy Act of 1992 (EPACT).

## Controls

Unit shall be completely factory wired with necessary controls and contactor pressure lugs or terminal block for power wiring. Units shall provide an external location for mounting a fused disconnect device.

24-volt electromechanical control circuit shall include control transformer and contactor pressure lugs for power wiring. Unit shall have single point power entry as standard.

## Accessories/Option

**Roof Curb**—The roof curb shall be designed to mate with the unit's downflow supply and return openings and provide support and a watertight installation when installed properly. The roof curb design shall allow field-fabricated rectangular supply/return ductwork to be connected directly to the curb. Curb design shall comply with NRCA requirements. Curbs shall be shipped knocked down for tool-less field assembly and shall include wood nailer strips.

**Economizer**—This accessory shall be either field or factory-installed and is available with barometric relief standard. The assembly includes direct drive gear driver, fully modulating 0-100 percent motor and dampers, minimum position setting, mixed air sensor, wiring harness with plug, and single enthalpy control. Optional differential enthalpy control shall be field-installed. The factory-installed economizer arrives ready for operation.

**Remote Potentiometer**—Field installed, the minimum position setting of economizer shall be adjusted with this accessory.

## Motorized Outside Air Dampers

Field-installed manually set outdoor air dampers shall provide up to 50 percent outside air. Once set, outdoor air dampers shall open to set position when indoor fan starts. The damper shall close to the full closed position when indoor fan shuts down.

**Manual Outside Air Damper**—Factory or field-installed rain hood and screen shall provide up to 50 percent outside air.

**Oversized Motors**—Factory installed belt drive oversized motors shall be available for high static applications.

**Powered Exhaust**—The field installed powered exhaust, available for all units, shall provide exhaust of return air, when using an economizer, to maintain better building pressurization.

[ ] Designates Metric Conversions



**Through the Base Electrical Access**—An electrical service entrance shall be factory provided allowing electrical access for both control and main power connection inside the curb and through the base of the unit. Option will allow for field installation of liquid-tight conduit and an external field-installed disconnect switch.

**Through the Base Electrical with Disconnect Switch**—Factory-installed 3-pole, molded case disconnect switch with provisions for through the base electrical connections are available. The disconnect switch will be installed in the unit in a watertight enclosure with access through a hinged door. Factory wiring will be provided from the switch to the unit high voltage terminal block. The switch will be UL/CSA agency recognized. Note: The disconnect switch will be sized per NEC and UL guidelines but will not be used in place of unit over current protection.

**Freeze/Clogged Filter Switches**—This factory or field-installed option allows for individual fan failure or dirty filter protection. If indoor coil gets too cold due to low airflow, compressor operation will be temporarily interrupted.

**Enthalpy Control**—Single Enthalpy Control shall be standard for all economizers. Enthalpy control offers a higher level of comfort control, along with energy savings potential, than the standard dry bulb control. This is due to the additional wet bulb sensing capability.

**High Pressure Cutout**—High pressure cutout shall be standard on all models and 1/4 turn fasteners. All scroll compressors shall include Internal Pressure Relief as standard.

**Thermostats**—Two stage heating and cooling operation shall be available, for field installation, in either manual or automatic changeover. Automatic programmable electronic with night set back shall also be available.

**Differential Enthalpy**—Adds on to the standard single control with other enthalpy sensors that compare total heat content of the indoor air and outdoor air to determine the most efficient air source. This control option offers the highest level of comfort control, plus energy efficiency available.

**Low Ambient Cooling**—Electromechanical models have cooling capabilities to 40°F as built, or to 0°F by adding the optional low ambient (frostat) control.



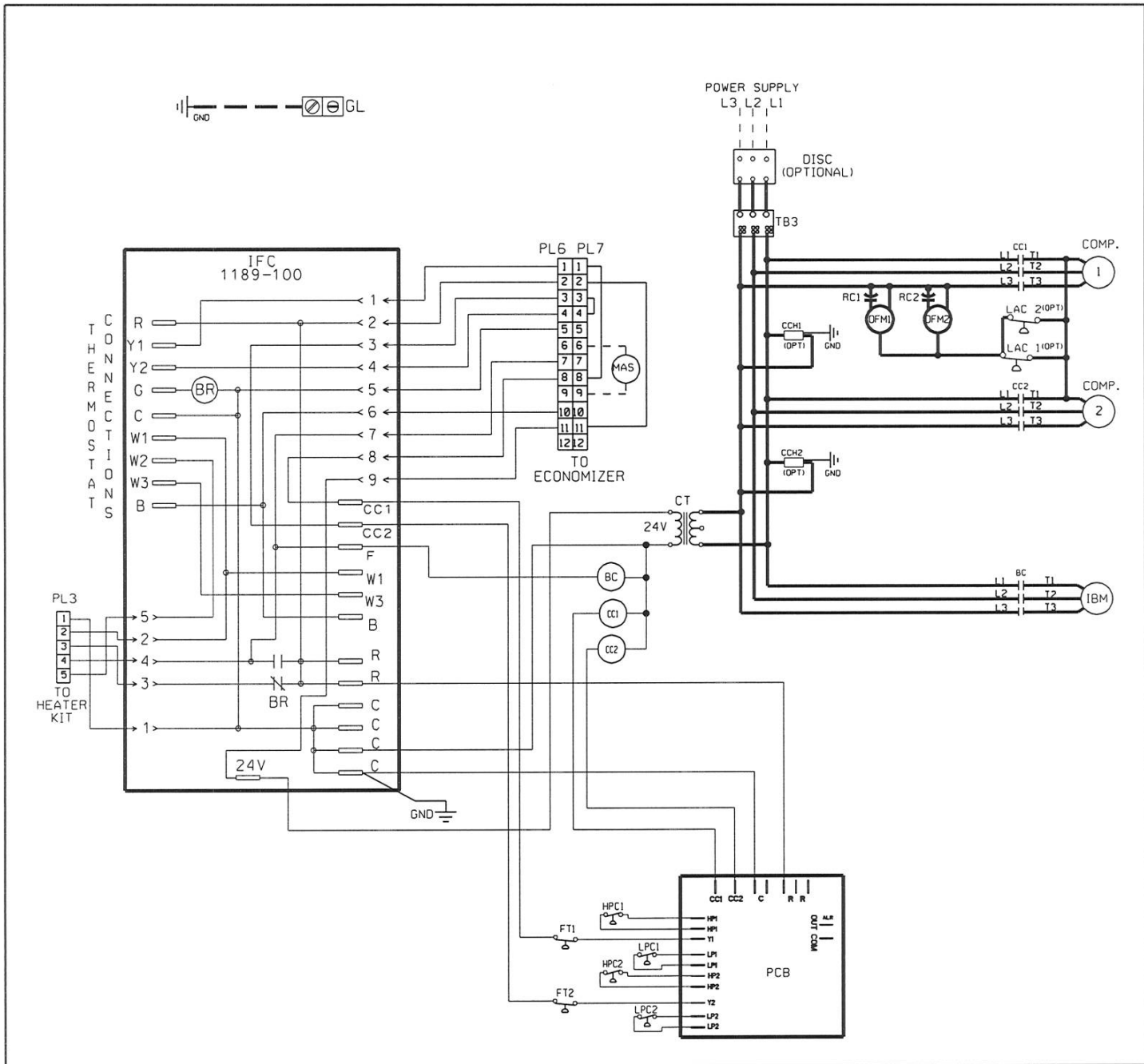

COMPONENT CODE		WIRING INFORMATION		WIRE COLOR CODE	
BC	BLOWER MOTOR CONTACTOR	---	FACTORY STANDARD	BK	BLACK
BR	BLOWER RELAY	- - - - -	FACTORY OPTION	BR	BROWN
CC	COMPRESSOR CONTACTOR	- - - - -	FIELD INSTALLED	BL	BLUE
CCH	CRANKCASE HEATER	---	FACTORY STANDARD	G	GREEN
COMP	COMPRESSOR	- - - - -	FACTORY OPTION	GY	GRAY
CT	CONTROL TRANSFORMER	---	FIELD INSTALLED	O	ORANGE
FT	FREEZE STAT	---	FACTORY STANDARD	PR	PURPLE
GL	GROUND LUG	---	FACTORY OPTION	R	RED
GND	GROUND	---	FIELD INSTALLED	W	WHITE
HPC	HIGH PRESSURE CONTROL	---	REPLACEMENT WIRE	Y	YELLOW
IBM	INDOOR BLOWER MOTOR	---	- MUST BE THE SAME SIZE AND TYPE OF INSULATION AS ORIGINAL (105° C MIN.)		
IFC	INTEGRATED FURNACE CONTROL	---	WARNING		
LAC	LOW AMBIENT CONTROL	---	- CABINET MUST BE PERMANENTLY GROUNDED AND CONFORM TO I.E.C., N.E.C., C.E.C., NATIONAL WIRING REGULATIONS, AND LOCAL CODES AS APPLICABLE.		
LPC	LOW PRESSURE CONTROL	---			
MAS	MIXED AIR SENSOR	---			
OFM	OUTDOOR FAN MOTOR	---			
OPT	OPTIONAL	---			
PCB	PRESSURE CONTROL BOARD	---			
PL	PLUG	---			
RC	RUN CAPACITOR	---			
TB	TERMINAL BLOCK	---			

WIRING SCHEMATIC					
(-)LKL/LNL-B151					
208-230, 3PH, 60HZ./460/575V, 3PH, 60HZ.					
200-220/380-415V 3PH, 50HZ					
DR. BY	APP. BY	DATE	DWG. NO.	REV	
MGR	MSB	8-16-12	90-102893-05	01	

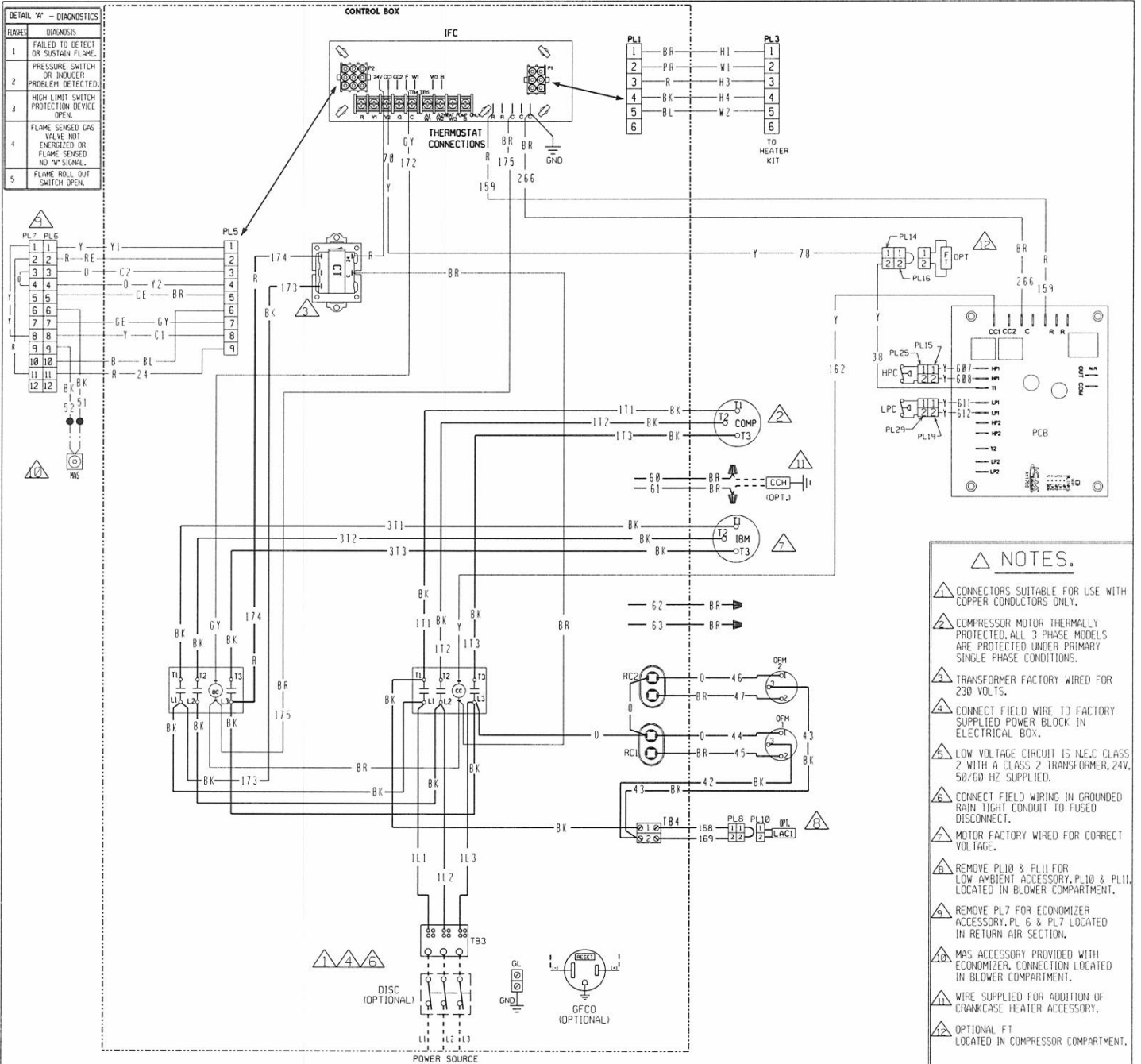

FLAME	DIAGNOSIS
1	FAILED TO DETECT OR SUSTAIN FLAME.
2	PRESSURE SWITCH OR INDUCER PROBLEM DETECTED.
3	HIGH LIMIT SWITCH PROTECTION DEVICE OPEN.
4	FLAME SENSED GAS VALVE NOT ENERGIZED OR FLAME SENSED NO "P" SIGNAL.
5	FLAME ROLL-OUT SWITCH OPEN.

- NOTES.**
- ⚠ CONNECTORS SUITABLE FOR USE WITH COPPER CONDUCTORS ONLY.
  - ⚠ COMPRESSOR MOTOR THERMALLY PROTECTED. ALL 3 PHASE MODELS ARE PROTECTED UNDER PRIMARY SINGLE PHASE CONDITIONS.
  - ⚠ TRANSFORMER FACTORY WIRED FOR 230 VOLTS.
  - ⚠ CONNECT FIELD WIRE TO FACTORY SUPPLIED POWER BLOCK IN ELECTRICAL BOX.
  - ⚠ LOW VOLTAGE CIRCUIT IS N.E.C. CLASS 2 WITH A CLASS 2 TRANSFORMER, 24V, 50/60 HZ SUPPLIED.
  - ⚠ CONNECT FIELD WIRING IN GROUNDED RAIN TIGHT CONDUIT TO FUSED DISCONNECT.
  - ⚠ MOTOR FACTORY WIRED FOR CORRECT VOLTAGE.
  - ⚠ REMOVE PL10 & PL11 FOR LOW AMBIENT ACCESSORY. PL10 & PL11 LOCATED IN BLOWER COMPARTMENT.
  - ⚠ REMOVE PL7 FOR ECONOMIZER ACCESSORY. PL 6 & PL7 LOCATED IN RETURN AIR SECTION.
  - ⚠ MAS ACCESSORY PROVIDED WITH ECONOMIZER. CONNECTION LOCATED IN BLOWER COMPARTMENT.
  - ⚠ WIRE SUPPLIED FOR ADDITION OF CRANKCASE HEATER ACCESSORY.
  - ⚠ OPTIONAL FT LOCATED IN COMPRESSOR COMPARTMENT.

COMPONENT CODE	
BC	BLOWER CONTACTOR
CC	COMPRESSOR CONTACTOR
CCH	CRANKCASE HEATER
COMP	COMPRESSOR
CT	CONTROL TRANSFORMER
DISC	DISCONNECT SWITCH
FLMS	FLAME SENSOR
FT	FREEZE STAT
GFCD	GROUND FAULT CONVENIENCE OUTLET
GL	GROUND LUG
GND	GROUND
GV	GAS VALVE
HPC	HIGH PRESSURE CONTROL
IBM	INDOOR BLOWER MOTOR BELT DRIVE
IDM	INDUCED DRAFT MOTOR
IFC	INTEGRATED FURNACE CONTROL
LAC	LOW AMBIENT COOLING CONTROL
LC	LIMIT CONTROL
LPC	LOW PRESSURE CONTROL
MAS	MIX AIR SENSOR
MRLC	MANUAL RESET LIMIT CONTROL
NPC	NEGATIVE PRESSURE CONTROL
OFM	OUTDOOR FAN MOTOR
PCB	PRESSURE CONTROL BOARD
PL	PLUG
RC	RUN CAPACITOR
SE	SPARK ELECTRODE
TB	TERMINAL BLOCK
W	WIRE NUT

**WIRING INFORMATION**

LINE VOLTAGE  
 -FACTORY STANDARD \_\_\_\_\_  
 -FACTORY OPTION - - - - -  
 -FIELD INSTALLED - - - - -

LOW VOLTAGE  
 -FACTORY STANDARD \_\_\_\_\_  
 -FACTORY OPTION - - - - -  
 -FIELD INSTALLED - - - - -

REPLACEMENT WIRE  
 -MUST BE THE SAME SIZE AND TYPE OF INSULATION AS ORIGINAL (105 C° MIN.)

WARNING  
 -CABINET MUST BE PERMANENTLY GROUNDED AND CONFORM TO I.E.C., N.E.C., C.E.C. AND LOCAL CODES AS APPLICABLE.

WIRE COLOR CODE			
BK	BLACK	O	ORANGE
BR	BROWN	PR	PURPLE
BL	BLUE	R	RED
G	GREEN	W	WHITE
GY	GRAY	Y	YELLOW

**WIRING DIAGRAM**  
**090/120**  
 208-230/460/575V 3 PH, 60 HZ.  
 200-220/380-415V, 3 PH, 50 HZ

DR. BY	APP. BY	DATE	DWG. NO.	REV
MGR	meb	8-14-12	90-102892-06	00

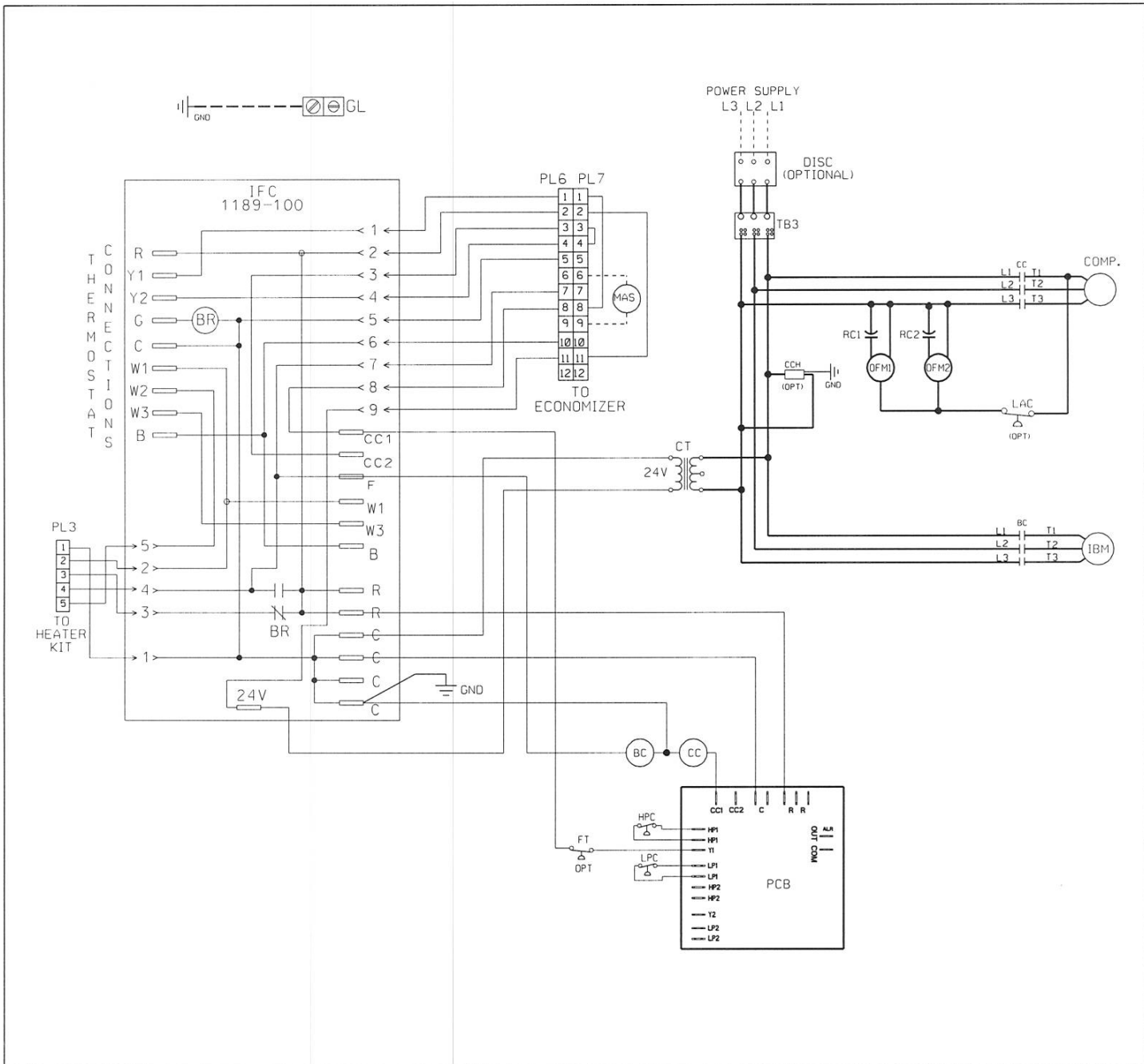

COMPONENT CODE		WIRING INFORMATION		WIRE COLOR CODE	
BC	BLOWER MOTOR CONTACTOR	LINE VOLTAGE	_____	BK	BLACK
BR	BLOWER RELAY	-FACTORY STANDARD	_____	BR	BROWN
CC	COMPRESSOR CONTACTOR	-FACTORY OPTION	-----	BL	BLUE
CCH	CRANKCASE HEATER	-FIELD INSTALLED	-----	G	GREEN
COMP	COMPRESSOR	LOW VOLTAGE	_____	GY	GRAY
CT	CONTROL TRANSFORMER	-FACTORY STANDARD	_____		
FT	FREEZE STAT	-FACTORY OPTION	-----		
GL	GROUND LUG	-FIELD INSTALLED	-----		
GND	GROUND	REPLACEMENT WIRE	_____		
HPC	HIGH PRESSURE CONTROL	-MUST BE THE SAME SIZE AND TYPE OF INSULATION AS ORIGINAL (105° C MIN.)	_____		
IBM	INDOOR BLOWER MOTOR	WARNING	_____		
IFC	INTEGRATED FURNACE CONTROL	-CABINET MUST BE PERMANENTLY GROUNDED AND CONFORM TO I.E.C., N.E.C., C.E.C., NATIONAL WIRING REGULATIONS, AND LOCAL CODES AS APPLICABLE.	_____		
LAC	LOW AMBIENT CONTROL		_____		
LPC	LOW PRESSURE CONTROL		-----		
MAS	MIXED AIR SENSOR		-----		
OFM	OUTDOOR FAN MOTOR		-----		
OPT	OPTIONAL		-----		
PCB	PRESSURE CONTROL BOARD		-----		
PL	PLUG		-----		
RC	RUN CAPACITOR		-----		
TB	TERMINAL BLOCK		-----		

WIRING SCHEMATIC			
090/120			
208-230/460/575V, 3PH, 60HZ.			
200-220/380-415V, 3 PH 50 HZ			
DR. BY	APP. BY	DATE	DWG. NO.
MGR	MEB	8-14-12	90-102893-06
			REV
			00

**BEFORE PURCHASING THIS APPLIANCE, READ IMPORTANT ENERGY COST AND EFFICIENCY INFORMATION AVAILABLE FROM YOUR RETAILER.**

**GENERAL TERMS OF LIMITED WARRANTY\***

Rheem will furnish a replacement for any part of this product which fails in normal use and service within the applicable periods stated, in accordance with the terms of the limited warranty.

**\*For complete details of the Limited and Conditional Warranties, including applicable terms and conditions, contact your local contractor or the Manufacturer for a copy of the product warranty certificate.**

**Compressor**

3 Phase, Commercial Applications .....Five (5) Years

**Parts**

3 Phase, Commercial Applications.....One (1) Year





The new degree of comfort.™

*In keeping with its policy of continuous progress and product improvement, Rheem reserves the right to make changes without notice.*

Rheem Heating, Cooling & Water Heating • P.O. Box 17010  
Fort Smith, Arkansas 72917 • [www.rheem.com](http://www.rheem.com)

Rheem Canada Ltd./Ltée • 125 Edgeware Road, Unit 1  
Brampton, Ontario • L6Y 0P5



INTEGRATED AIR & WATER