

# Maintenance

## Fan Belt Adjustment—Belt Drive Units

**⚠ WARNING**

**Rotating Components!**

During installation, testing, servicing and troubleshooting of this product it may be necessary to measure the speed of rotating components. Have a qualified or licensed service individual who has been properly trained in handling exposed rotating components, perform these tasks. Failure to follow all safety precautions when exposed to rotating components could result in death or serious injury.

The fan belts must be inspected periodically to assure proper unit operation.

Replacement is necessary if the belts appear frayed or worn. Units with dual belts require a matched set of belts to ensure equal belt length.

When removing or installing the new belts, do not stretch them over the sheaves. Loosen the belts using the belt tension adjustment bolts on the motor mounting base.

Once the new belts are installed, using a Browning or Gates tension gauge (or equivalent) illustrated in Figure 31; adjust the belt tension as follows:

1. To determine the appropriate belt deflection:
  - a. Measure the center-to-center shaft distance (in inches) between the fan and motor sheaves.
  - b. Divide the distance measured in Step 1a by 64; the resulting value represents the amount of belt deflection that corresponds to the proper belt tension.
2. Set the large O-ring on the belt tension gauge at the deflection value determined in Step 1b.
3. Set the small O-ring at zero on the force scale of the gauge plunger.
4. Place the large end of the gauge at the center of the belt span; then depress the gauge plunger until the large O-ring is even with the top of the next belt or even with a straightedge placed across the fan and motor sheaves. Refer to Figure 9.
5. Remove the belt tension gauge. The small O-ring now indicates a number other than zero on the plunger's force scale. This number represents the force (in pounds) required to give the needed deflection.
6. Compare the "force" scale reading (Step 5) with the appropriate "force" value listed in Table 10. If the "force" reading is outside the range, readjust the belt tension.

**Note:** Actual belt deflection "force" must not exceed the maximum "force" value shown in Table 10.

7. Recheck the belt tension at least twice during the first 2 to 3 days of operation. Belt tension may decrease until the new belts are "run in".

**Figure 31. Belt tension gauge**

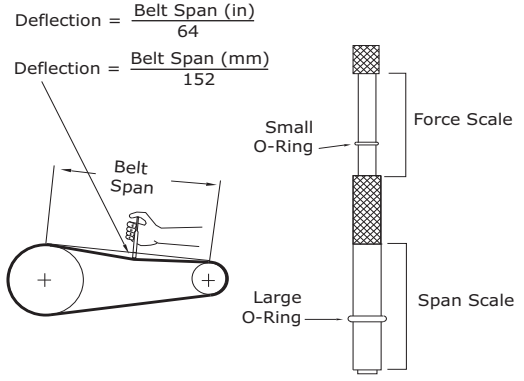

**Table 10. Belt tension measurement and deflection**

| Belts Cross-Section | Small P.D. Range | Deflection Force (Lbs) |       |           |        |                       |       |
|---------------------|------------------|------------------------|-------|-----------|--------|-----------------------|-------|
|                     |                  | Super Gripbelts        |       | Gripnotch |        | Steel Cable Gripbelts |       |
|                     |                  | Min.                   | Max.  | Min.      | Max.   | Min.                  | Max.  |
|                     | 3.0–3.6          | 3                      | 4 1/2 | 3 7/8     | 5 1/2  | 3 1/4                 | 4     |
| A                   | 3.8–4.8          | 3 1/2                  | 5     | 4 1/2     | 6 1/4  | 3 3/4                 | 4 3/4 |
|                     | 5.0–7.0          | 4                      | 5 1/2 | 5         | 6 7/8  | 4 1/4                 | 5 1/4 |
|                     | 3.4–4.2          | 4                      | 5 1/2 | 5 3/4     | 8      | 4 1/2                 | 5 1/2 |
| B                   | 4.4–5.6          | 5 1/8                  | 7 1/8 | 6 1/2     | 9 1/8  | 5 3/4                 | 7 1/4 |
|                     | 5.8–8.8          | 6 3/8                  | 8 3/4 | 7 3/8     | 10 1/8 | 7                     | 8 3/4 |

## Monthly Maintenance

**⚠ WARNING**

**Rotating Components!**

During installation, testing, servicing and troubleshooting of this product it may be necessary to measure the speed of rotating components. Have a qualified or licensed service individual who has been properly trained in handling exposed rotating components, perform these tasks. Failure to follow all safety precautions when exposed to rotating components could result in death or serious injury.

Before completing the following checks, turn the unit OFF and lock the main power disconnect switch open.

### Filters

Inspect the return air filters. Clean or replace them if necessary. Refer to the unit Service Facts for filter information.

## Condensate Overflow Switch

During maintenance, the switch float (black ring) must be checked to ensure free movement up and down.

## Cooling Season

- Check the unit's drain pans and condensate piping to ensure that there are no blockages.
- Inspect the evaporator and condenser coils for dirt, bent fins, etc. If the coils appear dirty, clean them according to the instructions described in "Coil Cleaning" later in this section.
- Manually rotate the condenser fan(s) to ensure free movement and check motor bearings for wear. Verify that all of the fan mounting hardware is tight.
- Inspect the F/A-R/A damper hinges and pins to ensure that all moving parts are securely mounted. Keep the blades clean as necessary.
- Verify that all damper linkages move freely; lubricate with white grease, if necessary.
- Check supply fan motor bearings; repair or replace the motor as necessary.
- Check the fan shaft bearings for wear. Replace the bearings as necessary.
- Check the supply fan belt. If the belt is frayed or worn, replace it. Refer to the "Fan Belt Adjustment" section for belt replacement and adjustments.
- Verify that all wire terminal connections are tight.
- Remove any corrosion present on the exterior surfaces of the unit and repaint these areas.
- Generally inspect the unit for unusual conditions (e.g., loose access panels, leaking piping connections, etc.)
- Make sure that all retaining screws are reinstalled in the unit access panels once these checks are complete.
- With the unit running, check and record the ambient temperature, compressor suction and discharge pressures (each circuit), and superheat (each circuit).
- Record this data on an "operator's maintenance log" like the one shown in [Table 11, p. 37](#). If the operating pressures indicate a refrigerant shortage, measure the system superheat. For guidelines, refer to the "Compressor Start-Up" section.

**Note:** Do not release refrigerant to the atmosphere! If adding or removing refrigerant is required, the service technician must comply with all federal, state and local laws.

## Heating Season

- Inspect the unit's air filters. If necessary, clean or replace them.
- Check supply fan motor bearings; repair or replace the motor as necessary.

- Inspect both the main unit control panel and heat section control box for loose electrical components and terminal connections, as well as damaged wire insulation. Make any necessary repairs.
- Clean burner area; verify gas heat system operates properly.

## Coil Cleaning

Regular coil maintenance, including annual cleaning, enhances the unit's operating efficiency by minimizing:

- Compressor head pressure and amperage draw
- Evaporator water carryover
- Fan brake horsepower, due to increased static pressure losses
- Airflow reduction

At least once each year, or more often if the unit is located in a "dirty" environment, clean the evaporator and condenser coils using the instructions outlined below. Be sure to follow these instructions as closely as possible to avoid damaging the coils.

**Note:** For units equipped with hail guards follow removal procedure listed below.

## Hail Guard Removal

- Unlatch hail guard.
- Pull the top of the hail guard outward until the fastener studs are free of the retaining nuts.
- Lift the hail guard from the lower retaining bracket and set aside.

To clean refrigerant coils, use a soft brush and a sprayer (either a garden pump-up type or a high-pressure sprayer). A high-quality detergent is also required; suggested brands include SPREX A.C., OAKITE 161, OAKITE 166, and COILO. If the detergent selected is strongly alkaline (ph value exceeds 8.5), add an inhibitor.

### **WARNING**

#### **Hazardous Chemicals!**

**Coil cleaning agents can be either acidic or highly alkaline. Handle chemical carefully. Proper handling should include goggles or face shield, chemical resistant gloves, boots, apron or suit as required. For personal safety refer to the cleaning agent manufacturer's Materials Safety Data Sheet and follow all recommended safe handling practices. Failure to follow all safety instructions could result in death or serious injury.**

1. Remove enough panels from the unit to gain access to the coil.
2. Protect all electrical devices such as motors and controllers from any over spray.
3. Straighten any bent coil fins with a fin comb.

## Maintenance

---

- Mix the detergent with water according to the manufacturer's instructions. If desired, heat the solution BUT DO NOT EXCEED 150°F maximum to improve its cleansing capability.

### **⚠ WARNING**

#### **Hazardous Pressures!**

**Coils contain refrigerant under pressure. When cleaning coils, maintain coil cleaning solution temperature under 150°F to avoid excessive pressure in the coil. Failure to follow these safety precautions could result in coil bursting, which could result in death or serious injury.**

- Pour the cleaning solution into the sprayer. If a high-pressure sprayer is used:
  - Do not allow sprayer pressure to exceed 600 psi.
  - The minimum nozzle spray angle is 15 degrees.
  - Maintain a minimum clearance of 6" between the sprayer nozzle and the coil.
  - Spray the solution perpendicular (at 90 degrees) to the coil face.
- Spray the leaving-airflow side of the coil first; then spray the opposite side of the coil. Allow the cleaning solution to stand on the coil for 5 minutes.
- Rinse both sides of the coil with cool, clean water.
- Inspect both sides of the coil; if it still appears to be dirty, repeat Steps 6 and 7.
- Reinstall all of the components and panels removed in Step 1 and any protective covers installed in Step 2.

**Note:** For units equipped with hail guards follow reinstallation procedure listed below.

## Hail Guard Reinstallation

- To reinstall the hail guard, locate the bottom of the hail guard in the lower bracket and secure it to the upper unit bracket with the attached fasteners.

**Note:** Secure hail guard latches.

**Figure 32. Slide latch**

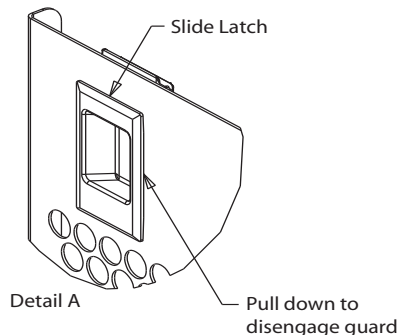

- Restore the unit to its operational status and check system operation.

## Annual Maintenance

- Clean and repaint any corroded surface.

## Final Process

For future reference, you may find it helpful to record the unit data requested in the blanks provided.

**Complete Model Number**

\_\_\_\_\_

**Unit Serial Number**

\_\_\_\_\_

**Schematics**

\_\_\_\_\_

**Connections**

\_\_\_\_\_

### Wiring Diagram Numbers (from unit control panel)

Table 11. Sample maintenance log

| Date | Current Ambient Temp. F/C | Compr. Oil Level | Refrigerant Circuit #1 |                        |                        |                |               | Refrigerant Circuit #2 |                       |                        |                        |                |               |  |
|------|---------------------------|------------------|------------------------|------------------------|------------------------|----------------|---------------|------------------------|-----------------------|------------------------|------------------------|----------------|---------------|--|
|      |                           |                  | Suct. Press. Psig/kPa  | Disch. Press. Psig/kPa | Liquid Press. Psig/kPa | Super-heat F/C | Sub-cool. F/C | Compr. Oil Level       | Suct. Press. Psig/kPa | Disch. Press. Psig/kPa | Liquid Press. Psig/kPa | Super-heat F/C | Sub-cool. F/C |  |
|      |                           | - ok<br>- low    |                        |                        |                        |                |               |                        |                       |                        |                        |                |               |  |
|      |                           | - ok<br>- low    |                        |                        |                        |                |               |                        |                       |                        |                        |                |               |  |
|      |                           | - ok<br>- low    |                        |                        |                        |                |               |                        |                       |                        |                        |                |               |  |
|      |                           | - ok<br>- low    |                        |                        |                        |                |               |                        |                       |                        |                        |                |               |  |
|      |                           | - ok<br>- low    |                        |                        |                        |                |               |                        |                       |                        |                        |                |               |  |
|      |                           | - ok<br>- low    |                        |                        |                        |                |               |                        |                       |                        |                        |                |               |  |
|      |                           | - ok<br>- low    |                        |                        |                        |                |               |                        |                       |                        |                        |                |               |  |
|      |                           | - ok<br>- low    |                        |                        |                        |                |               |                        |                       |                        |                        |                |               |  |
|      |                           | - ok<br>- low    |                        |                        |                        |                |               |                        |                       |                        |                        |                |               |  |
|      |                           | - ok<br>- low    |                        |                        |                        |                |               |                        |                       |                        |                        |                |               |  |
|      |                           | - ok<br>- low    |                        |                        |                        |                |               |                        |                       |                        |                        |                |               |  |
|      |                           | - ok<br>- low    |                        |                        |                        |                |               |                        |                       |                        |                        |                |               |  |

**Note:** Check and record the data requested above each month during the cooling season with the unit running.



# Troubleshooting

## ReliaTel™ Control

The RTRM has the ability to provide the service personnel with some unit diagnostics and system status information.

Before turning off the main power disconnect switch, use the following steps to check the ReliaTel Refrigeration Module (RTRM). All diagnostics and system status information stored in the RTRM will be lost when the main power is turned off.

**⚠ WARNING**

**Live Electrical Components!**

**During installation, testing, servicing and troubleshooting of this product, it may be necessary to work with live electrical components. Have a qualified licensed electrician or other individual who has been properly trained in handling live electrical components perform these tasks. Failure to follow all electrical safety precautions when exposed to live electrical components could result in death or serious injury.**

To prevent injury or death from electrocution, it is the responsibility of the technician to recognize this hazard and use extreme care when performing service procedures with the electrical power energized.

1. Verify that the Liteport LED on the RTRM is burning continuously. If the LED is lit, go to Step 3.
2. If the LED is not lit, verify that 24 VAC is present between J1-1 and J1-2. If 24 VAC is present, proceed to Step 3. If 24 VAC is not present, check the unit main power supply and check the transformer (TNS1). Proceed to Step 3 if necessary.
3. Using "Method 1" or "Method 2" in the "System Status Diagnostic" section, check the following:
  - System status
  - Heating status
  - Cooling status
 If a System failure is indicated, proceed to Step 4. If no failures are indicated, proceed to Step 5.
4. If a System failure is indicated, recheck Steps 1 and 2. If the LED is not lit in Step 1, and 24 VAC is present in Step 2, the RTRM has failed. Replace the RTRM.
5. If no failures are indicated, use one of the TEST mode procedures described in the "Unit Start-Up" section to start the unit. This procedure allows you to check all of the RTRM outputs and all of the external controls (relays, contactors, etc.) that the RTRM outputs energize, for each respective mode. Proceed to Step 6.
6. Step the system through all of the available modes, and verify operation of all outputs, controls, and modes. If a problem in operation is noted in any mode, you may leave the system in that mode for up to one hour while troubleshooting. Refer to the sequence of

operations for each mode, to assist in verifying proper operation. Make the necessary repairs and proceed to Steps 7 and 8.

7. If no abnormal operating conditions appear in the test mode, exit the test mode by turning the power to OFF at the main power disconnect switch.
8. Refer to the individual component test procedures if other microelectronic components are suspect.

## System Status Checkout Procedure

Check system status by using one of the following two methods:

### Method 1

If the Zone Sensor Module (ZSM) is equipped with a remote panel with LED status indication, you can check the unit within the space. If the ZSM does not have LEDs, use Method 2. BAYSENS110\*, BAYSENS109\*, BAYSENS119\*, BAYSENS023A all have the remote panel indication feature. The LED descriptions are listed below.

#### LED 1 (System)

|          |                                         |
|----------|-----------------------------------------|
| On       | During normal operation                 |
| Off      | If a system failure occurs or LED fails |
| Flashing | Indicates test mode                     |

#### LED 2 (Heat)

|          |                                             |
|----------|---------------------------------------------|
| On       | When the heat cycle is operating            |
| Off      | When the heat cycle terminates or LED fails |
| Flashing | Indicates a heating failure                 |

#### LED 3 (Cool)

|          |                                                |
|----------|------------------------------------------------|
| On       | When the cooling cycle is operating            |
| Off      | When the cooling cycle terminates or LED fails |
| Flashing | Indicates a cooling failure                    |

#### LED 4 (Service)

|          |                                                                           |
|----------|---------------------------------------------------------------------------|
| On       | Indicates a clogged filter                                                |
| Off      | During normal operation                                                   |
| Flashing | Indicates an evaporator fan failure or condensate overflow switch failure |

The following sections contain a complete listing of failure indication causes.

### System failure

Check the voltage between terminals 6 and 9 on J6; it should read approximately 32 VDC. If no voltage is present, a system failure has occurred. Refer to Step 4 in

the previous section for the recommended troubleshooting procedure.

### Heating Failure

Verify heat failure by ignition module (IGN) LED indicator:

|            |                           |                         |
|------------|---------------------------|-------------------------|
| Off        | No power or power failure |                         |
| On         | Normal                    |                         |
| Slow flash | Normal, heat call         |                         |
| Fast flash | 1 flash                   | Communication failure   |
|            | 2 flashes                 | System lockout          |
|            | 3 flashes                 | Pressure switch fail    |
|            | 4 flashes                 | TC01 or TC02 open       |
|            | 5 flashes                 | Flame without gas valve |
|            | 6 flashes                 | Flame rollout open      |

### Cooling Failure

- Cooling and heating set point (slide pot) on the zone sensor has failed. Refer to the "Zone Sensor Test Procedure" section.
- Zone temperature thermistor ZTEMP on ZTS failed. Refer to the "Zone Sensor Test Procedure" section.
- CC1 or CC2 24 VAC control circuit has opened—check CC1 and CC2 coils and any of the controls below that apply to the unit (HPC1, HPC2).
- LPC1 has opened during the 3-minute minimum "on time" during 4 consecutive compressor starts—check LPC1 or LPC2 by testing voltage between the J1-1 and J3-2 terminals on the RTRM and ground. If 24 VAC is present, the LPCs has not tripped. If no voltage is present, LPCs has tripped.

### Service Failure

- If the supply fan proving switch has closed, the unit will not operate (when connected to RTOM)—check the fan motor, belts, and proving switch.
- Clogged filter switch has closed—check the filters.
- If the condensate overflow switch is closed, the unit will not operate—check the float position is not in a tripped condition and verify an "open" between wires connecting to RTOM J6-1, J6-2 (ReliaTel™ controls).

### Simultaneous Heat and Cool Failure

- Emergency stop is activated

### Method 2

The second method for determining system status is done by checking voltage readings at the RTRM (J6). The following sections list system indication descriptions and the approximate voltages.

### System Failure

- Measure the voltage between terminals J6-9 and J6-6.
- Normal operation = approximately 32 VDC

- System failure = less than 1 VDC, approximately 0.75 VDC
- Test mode = voltage alternates between 32 VDC and 0.75 VDC

### Heat Failure

- Measure the voltage between terminals J6-7 and J6-6.
- Heat operating = approximately 32 VDC
- Heat off = less than 1 VDC, approximately 0.75 VDC
- Heating failure = voltage alternates between 32 VDC and 0.75 VDC

### Cool Failure

- Measure the voltage between terminals J6-8 and J6-6.
- Cool Operating = approximately 32 VDC
- Cool Off = less than 1 VDC, approximately 0.75 VDC
- Cooling Failure = voltage alternates between 32 VDC and 0.75 VDC

### Service Failure

- Measure the voltage between terminals J6-10 and J6-6.
- Clogged filter = approximately 32 VDC.
- Normal = less than 1 VDC, approximately 0.75 VDC
- Fan Failure = voltage alternates between 32 VDC and 0.75 VDC.

To use LEDs for quick status information at the unit, purchase a BAYSENS110\* ZSM and connect wires with alligator clamps to terminals 6 through 10. Connect each respective terminal wire (6 through 10) from the Zone Sensor to the unit J6 terminals 6 through 10.

**Note:** *If the system is equipped with a programmable zone sensor, (BAYSENS119\*, or BAYSENS023A), the LED indicators will not function while the BAYSENS110\* is connected.*

### Resetting Cooling and Ignition Lockouts

Cooling failures and heating lockouts are reset in an identical manner. Method 1 explains resetting the system from the space; Method 2 explains resetting the system at the unit.

**Note:** *Before resetting Cooling Failures and Ignition Lockouts check the Failure Status Diagnostics by the methods previously explained. Diagnostics will be lost when the power to the unit is disconnected.*

### Resetting Lockouts—Method 1

To reset the system from the space, turn the "Mode" selection switch at the zone sensor to the OFF position. After approximately 30 seconds, turn the "Mode" selection switch to the desired mode, e.g., Heat, Cool, or Auto.



### Resetting Lockouts—Method 2

To reset the system at the unit, cycle the unit power by turning the disconnect switch to OFF and then to ON. Lockouts can be cleared through the building management system. Refer to the building management system instructions for more information.

## Zone Temperature Sensor (ZTS) Service Indicator

The ZSM SERVICE LED is a generic indicator that will signal the closing of a Normally Open switch at any time, providing the Indoor Motor (IDM) is operating. This indicator is usually used to indicate a clogged filter or an air side fan failure.

The RTRM will ignore the closing of this Normally Open switch for 2 (±1) minutes. This helps prevent nuisance SERVICE LED indications. The exception is the LED will flash 40 seconds after the fan is turned to ON if the Fan Proving Switch is not made.

### Clogged Filter Switch

This LED will remain lit the entire time that the Normally Open switch is closed. The LED will be turned off immediately after resetting the switch (to the Normally Open position), or any time that the IDM is turned to OFF.

If the switch remains closed, and the IDM is turned to ON, the SERVICE LED will be turned to ON again after the 2 (±1) minute ignore delay.

This LED being turned to ON will have no other affect on unit operation. It is an indicator only.

### Fan Failure Switch

When the “Fan Failure” switch is wired to the RTOM, the LED will remain flashing the entire time the fan proving switch is closed, indicating a fan failure, and it will shut down the unit operations.

### Condensate Overflow Switch

When the “Condensate Overflow Switch” is closed, a drain pan overflow condition is indicated, and it will shut unit operations down.

## Zone Temperature Sensor (ZTS) Test

**Note:** *These procedures are not for programmable or digital models and are conducted with the Zone Sensor Module electrically removed from the system.*

## Test 1—Zone Temperature Thermistor (ZTEMP)

This component is tested by measuring the resistance between terminals 1 and 2 on the Zone Temperature Sensor. Below are some typical indoor temperatures, and corresponding resistive values.

## Test 2—Cooling Set Point (CSP) and Heating Set Point (HSP)

**Table 12. Cooling setpoint and heating setpoint**

| Zone  | Temperature | Nominal ZTEMP Resistance |
|-------|-------------|--------------------------|
| 50°F  | 10.0 C°     | 19.9 K-Ohms              |
| 55 F° | 12.8 C°     | 17.47 K-Ohms             |
| 60 F° | 15.6 C°     | 15.3 K-Ohms              |
| 65 F° | 18.3 C°     | 13.49 K-Ohms             |
| 70 F° | 21.1 C°     | 11.9 K-Ohms              |
| 75 F° | 23.9 C°     | 10.50 K-Ohms             |
| 80 F° | 26.7 C°     | 9.3 K-Ohms               |
| 85 F° | 29.4 C°     | 8.25 K-Ohms              |
| 90 F° | 32.2 C°     | 7.3 K-Ohms               |

The resistance of these potentiometers are measured between the following ZSM terminals. Refer to the chart above for approximate resistances at the given setpoints.

Cool SP = Terminals 2 and 3

Range = 100 to 900 Ohms approximate

Heat SP = Terminals 2 and 5

Range = 100 to 900 Ohms approximate

## Test 3—System Mode and Fan Selection

The combined resistance of the Mode selection switch and the Fan selection switch can be measured between terminals 2 and 4 on the Zone Sensor. The possible switch combinations are listed below with their corresponding resistance values.

## Test 4—LED Indicator Test, (SYS ON, HEAT, COOL, and SERVICE)

### Method 1

Testing the LED using a meter with diode test function. Test both forward and reverse bias. Forward bias should measure a voltage drop of 1.5 to 2.5 volts, depending on your meter. Reverse bias will show an Over Load, or open circuit indication if LED is functional.

### Method 2

Testing the LED with an analog Ohmmeter. Connect Ohmmeter across LED in one direction; then reverse the leads for the opposite direction. The LED should have at least 100 times more resistance in reverse direction, as compared with the forward direction. If high resistance in both directions, LED is open. If low in both directions, LED is shorted.

## Method 3

To test LEDs with ZSM connected to unit, test voltages at LED terminals on ZSM. A measurement of 32 VDC, across an unlit LED, means the LED has failed.

## Programmable and Digital Zone Sensor Test

Testing serial communication voltage

1. Verify 24 VAC is present between terminals J6-14 and J6-11.
2. Disconnect wires from J6-11 and J6-12. Measure the voltage between J6-11 and J6-12; it should be about 32 VDC.
3. Reconnect wires to terminals J6-11 and J6-12. Measure voltage again between J6-11 and J6-12; voltage should flash high and low every 0.5 seconds. The voltage on the low end will measure about 19 VDC, while the voltage on the high end will measure from approximately 24 to 38 VDC.
4. Verify all modes of operation, by running the unit through all of the steps in the "Test Modes" section discussed in "Unit Start-Up".
5. After verifying proper unit operation, exit the test mode. Turn on the fan continuously at the ZSM, by pressing the button with the fan symbol. If the fan comes on and runs continuously, the ZSM is good. If you are not able to turn on the fan, the ZSM is defective.

## ReliaTel™ Refrigeration Module (RTRM) Default Chart

If the RTCl loses input from the building management system, the RTRM will control in the default mode after approximately 15 minutes. If the RTRM loses the Heating and Cooling setpoint input, the RTRM will control in the default mode instantaneously. The temperature sensing thermistor in the Zone Sensor Module is the only component required for the "Default Mode" to operate.

## Unit Operation without a Zone Sensor

This procedure is for temporary operation only. The economizer and condenser fan cycling functions are disabled.

### WARNING

#### Hazardous Voltage!

**Disconnect all electric power, including remote disconnects before servicing. Follow proper lockout/tagout procedures to ensure the power can not be inadvertently energized. Failure to disconnect power before servicing could result in death or serious injury.**

1. Open and lock the unit disconnect switch.
2. Remove the Outside Air Sensor (OAS) from the condenser section of unit.

3. Use 2 wire nuts to individually cap the wires.
4. Locate the RTRM (J6). Connect 2 wires to terminals J6-1 and 2.
5. Connect the sensor (OAS) using two wire nuts to the 2 field-supplied wires that were connected to terminals 1 and 2 on J6.

## Unit Economizer Control (ECA) Troubleshooting

### ReliaTel Control

Verify economizer status by economizer actuator (ECA) LED indicator:

|                    |                             |                        |
|--------------------|-----------------------------|------------------------|
| Off                | No power or power failure   |                        |
| On                 | Normal, OK to economize     |                        |
| Slow flash         | Normal, not OK to economize |                        |
| Fast flash         | Communications failure      |                        |
| ½ sec on/2 sec off |                             |                        |
| Pulse flash        | 1 flash                     | Actuator fault         |
| 2 sec on/½ sec off | 2 flashes                   | CO <sub>2</sub> sensor |
|                    | 3 flashes                   | RA humidity sensor     |
|                    | 4 flashes                   | RA temp sensor         |
|                    | 5 flashes                   | OA quality sensor      |
|                    | 6 flashes                   | OA humidity sensor     |
|                    | 7 flashes                   | OA temp sensor         |
|                    | 8 flashes                   | MA temp sensor         |
|                    | 9 flashes                   | RAM fault              |
|                    | 10 flashes                  | ROM fault              |
|                    | 11 flashes                  | EEPROM fault           |

### Heating Failure

Verify heat failure by ignition module (IGN) LED indicator:

|            |                           |                      |
|------------|---------------------------|----------------------|
| Off        | No power or power failure |                      |
| On         | Normal                    |                      |
| Slow flash | Normal, heat call         |                      |
| Fast flash | 1 flash                   | No communication     |
|            | 2 flashes                 | System lockout       |
|            | 3 flashes                 | Pressure switch fail |
|            | 4 flashes                 | TC01 or TC02 open    |
|            | 5 flashes                 | Flame w/o gas valve  |
|            | 6 flashes                 | Flame rollout open   |

### Cooling Failure

- Cooling and heating set point (slide pot) on the thermostat has failed.
- CC1 or CC2 24 VAC control circuit has opened, check CC1 and CC2 coils, and any of the controls below that apply to the unit (HPC1, HPC2, LPC1, LPC2, Froststat™).





## Resetting Cooling and Ignition Lockouts

Cooling failures and ignition lockouts are reset in an identical manner. Method 1 explains resetting the system from the space; Method 2 explains resetting the system at the unit.

### Resetting Lockouts—Method 1

To reset the system from the space, turn the “Mode” selection switch at the thermostat to the OFF position. After approximately 30 seconds, turn the “Mode” selection switch to the desired mode, e.g., Heat, Cool, or Auto.

### Resetting Lockouts—Method 2

To reset the system at the unit, cycle the unit power by turning the disconnect switch to OFF and then to ON.



# Unit Wiring Diagrams Numbers

**Note:** Wiring diagrams can be accessed using e-Library by entering the diagram number in the literature

order number search field or by contacting technical support.

**Table 13. Unit wiring diagram numbers**

| Schematic Type |                |                    | Description |
|----------------|----------------|--------------------|-------------|
| Control        | Power          | Connection Diagram |             |
| 4366-1012-0110 | 4366-1005-0104 | 4366-1543-0110     | 060EDR      |
| 4366-1015-0104 | 4366-1005-0104 | 4366-1540-0110     | 072EDR      |
| 4366-1015-0104 | 4366-1005-0104 | 4366-1540-0110     | 090EDR      |
| 4366-1042-0110 | 4366-1034-0110 | 4366-1532-0110     | 102EDR      |
| 4366-1042-0110 | 4366-1034-0110 | 4366-1532-0110     | 120EDR      |
| 4366-2231-0110 | 4366-2230-0110 | 4366-2236-0110     | 060EDK      |
| 4366-2231-0110 | 4366-2230-0110 | 4366-2236-0110     | 072EDK      |
| 4366-2231-0110 | 4366-2230-0110 | 4366-2236-0110     | 090EDK      |
| 4366-2231-0110 | 4366-2230-0110 | 4366-2236-0110     | 102EDK      |
| 4366-2231-0110 | 4366-2230-0110 | 4366-2236-0110     | 120EDK      |