



COMMERCIAL AIR HANDLER

FORM NO. H11-529 REV. 6
Supersedes Form No. H11-529 Rev. 5

Featuring Industry Standard R-410A Refrigerant

R-410A

RHGL- 090, 120, 180 & 240 SERIES
NOMINAL SIZES 7.5, 10, 15 & 20 TONS [26, 35, 53, & 70 kW]

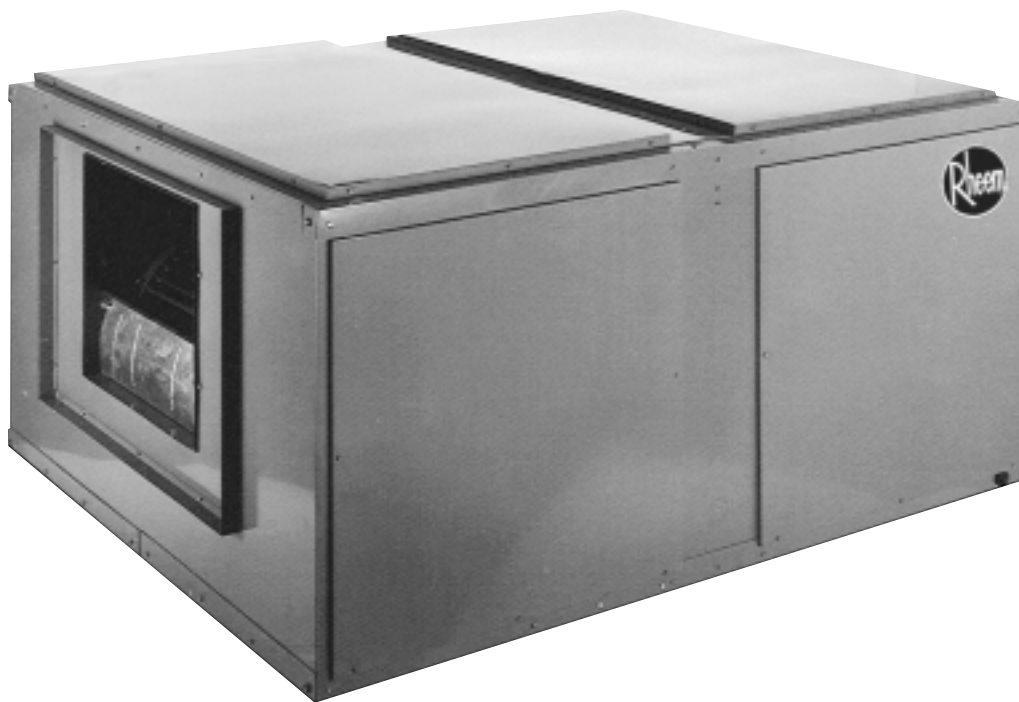

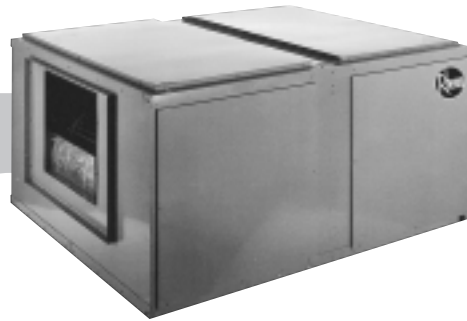

Unit Features.....	3
Model Identification Options.....	3
Component Location	4
Unit Dimensions.....	5
Physical Data/Drive Package Data.....	6-7
Airflow Performance Data	8-12
Performance Data	13-15
Electric Heater Kits	15-16
Accessories.....	17-23
Piping	24
Guide Specifications	25
Limited Warranty	28



UNIT FEATURES/MODEL IDENTIFICATION—RHGL- SERIES

CABINET—Powder coat painted. Matching discharge plenums and decorative supply and return air grilles are available for use when units are to be installed within conditioned space.

MOTOR—Inherently protected motors are mounted inside of insulated cabinet to reduce motor noise. A choice of motor horsepower and drive combinations are available to allow you to meet specified CFM at various static pressures up to 2" [.498 kPa] external static pressure.

LOW PROFILE—Allows for horizontal installation in most standard drop ceiling applications, and the movement of units through most standard doorways for addition or replacement work.

THERMAL EXPANSION VALVES—Standard all models.

FILTERS—One inch [25 mm] throwaway filters are standard, but filter racks are designed to accept either one inch [25 mm] or two inch [51 mm] filters.

EVAPORATOR COIL—Two circuit, interlaced row split coils are constructed with copper tubes and aluminum fins mechanically bonded to the tubes for maximum heat transfer capabilities. All coil assemblies are leak tested up to 450 PSIG [3100 kPa] internal pressure prior to installation into units.

REFRIGERANT CONNECTIONS—Field piping connections are made through a fixed post between two side access panels on either side of the unit. Allows flexibility to meet most field conditions as well as full accessibility after the installation is complete.

Units may be used with two straight cool condensing units or single circuit manifolded in the field using the copper fittings shipped with each unit. The RHGL Air Handler has not been tested, rated or certified to operate with dual residential remote heat pumps.

DRAIN PAN—The galvanized steel drain pan is designed to trap condensate in either vertical or horizontal installations. Condensate drain connections are located on both sides of the unit allowing complete flexibility to meet most field conditions.

SERVICE ACCESS—Two removable panels on top and each side of the unit are easily removed for access to motors, blowers, sheaves, and filters.

HORIZONTAL OR VERTICAL—All models are designed for either application and can be installed in either position as supplied from the factory. (See page 22)

TESTING—All units are run tested at the factory prior to shipment. Units are shipped with a holding charge of nitrogen.

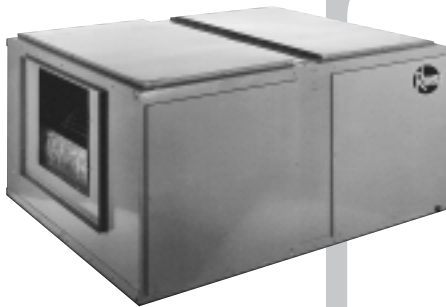

R H G L — 120 Z L

Drive Package (see page 8)
J = Optional (Field Supplied)
*K = Standard
L = Optional
M = Optional
N = Optional (Field Supplied)
O = Optional (Field Supplied)

Electrical Designation
*H = 115-230-1-60 (090/120 only)
Z = 208-230/460-3-60
Y = 575-3-60

Nominal Tons
090 = 7.5 Tons [26 kW]
120 = 10.0 Tons [35 kW]
180 = 15.0 Tons [53 kW]
240 = 20.0 Tons [70 kW]

Design Series
L = Refrigerant R-410A

Type

Air Handler

Rheem

*"H" voltage models are available with "K" drive package only.

[] Designates Metric Conversions

COMPONENT LOCATION—RHGL- SERIES

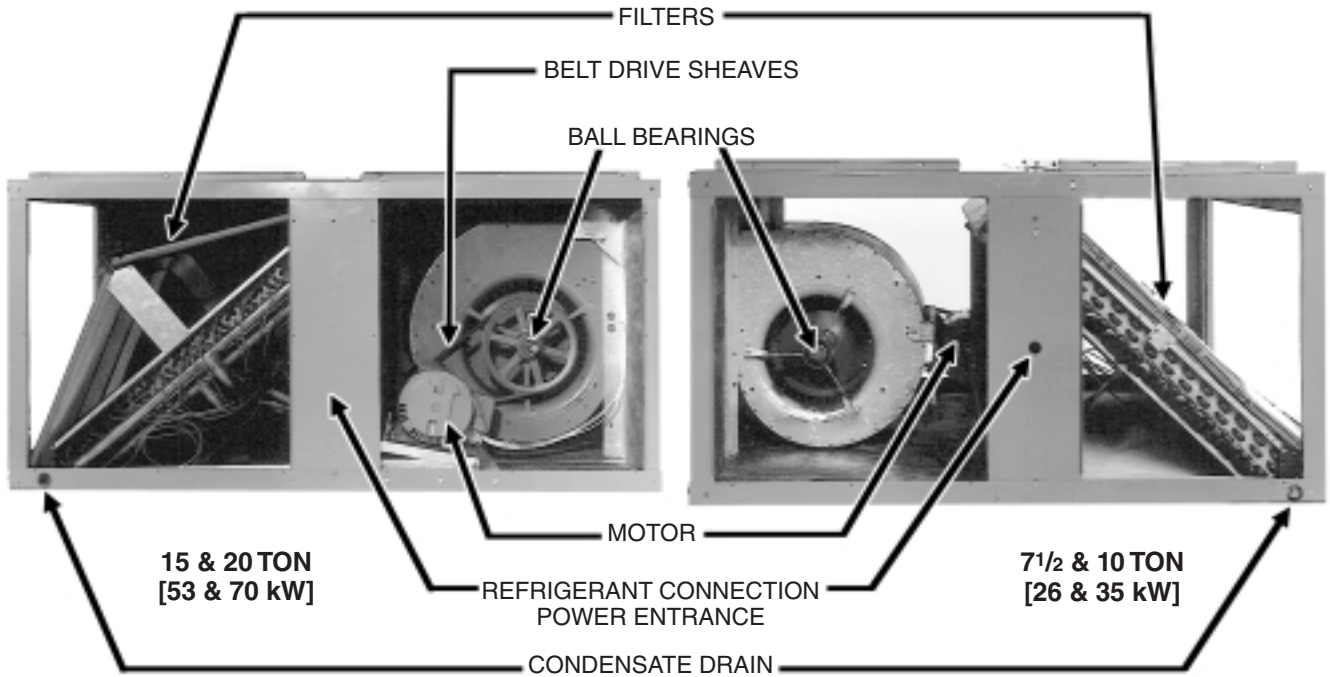

15 ton [53 kW] & 20 ton [70 kW] unit with side panel removed for blower and air filter access.

7 1/2 ton [26 kW] & 10 ton [35 kW] unit with side panel removed for coil connections and air filter access.

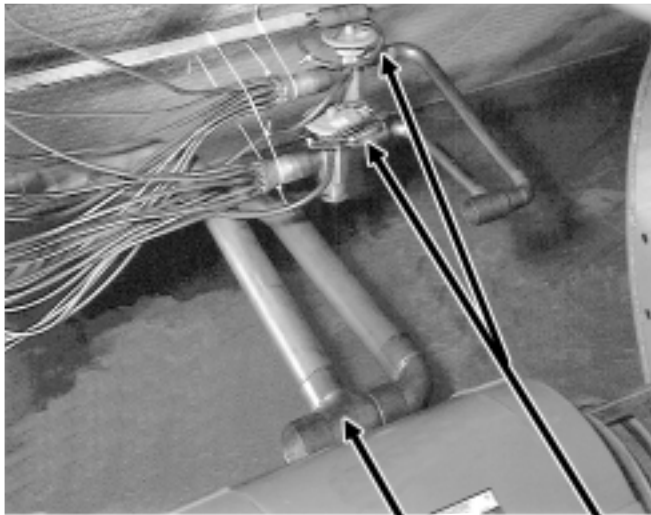

**RHGL-
7 1/2-20 TON
[26-70 kW]**

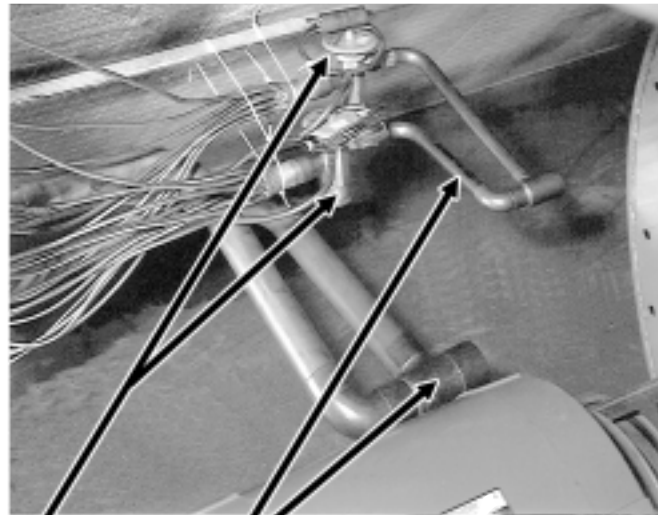

**RHGL-
7 1/2-20 TON
[26-70 kW]**

TX VALVES
SINGLE CIRCUIT MANIFOLD
REFRIGERANT CONNECTION
EITHER SIDE

[] Designates Metric Conversions



UNIT DIMENSIONS—RHGL- SERIES

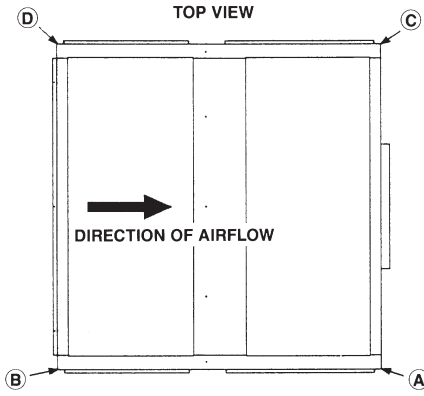

RETURN AIR OPENINGS = 47³/₈" [1203] WIDTH x 19⁷/₈" [505] HEIGHT

7¹/₂ AND 10 NOMINAL TONS [26 AND 35 kW]

MODEL	REFRIGERANT STUB SIZES, IN. [mm]			
	DUAL LIQ.	DUAL SUC.	SINGLE LIQ.	SINGLE SUC.
090	1/2, 1/2 [13, 13]	7/8, 7/8 [22, 22]	1/2 [13]	1 1/8 [29]
120	1/2, 1/2 [13, 13]	7/8, 7/8 [22, 22]	5/8 [16]	1 3/8 [35]

MODEL	CORNER WEIGHTS, LBS. [kg]				TOTAL WEIGHT
	A	B	C	D	
090	88 [40]	78 [35]	87 [39]	77 [35]	330 [150]
120	93 [42]	82 [37]	92 [42]	80 [36]	347 [157]

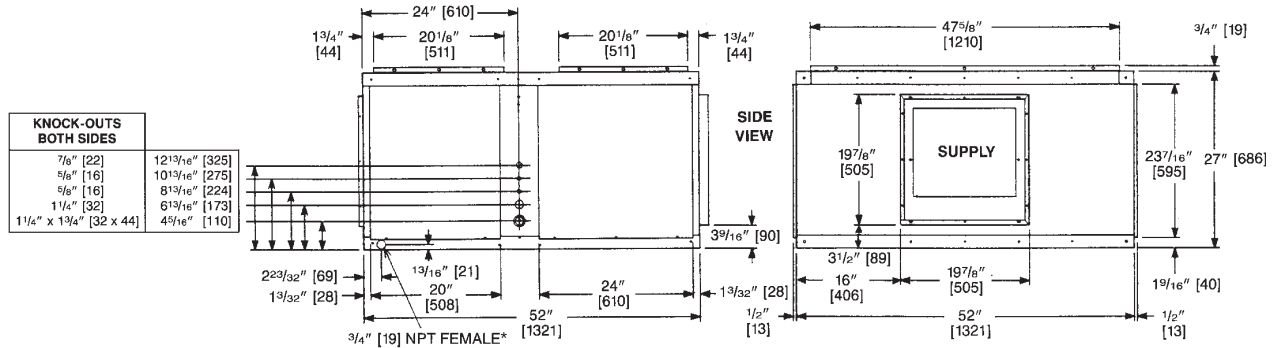

*Drain connections are provided on both sides of the drain pan. The drain can be connected to either side of the drain pan, but not both. The drain must be trapped.

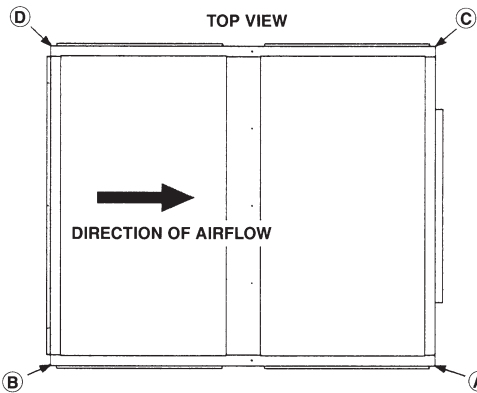

RETURN AIR OPENINGS = 55¹/₂" [1410] WIDTH x 30⁹/₁₆" [776] HEIGHT

15 AND 20 NOMINAL TONS [53 & 70 kW]

MODEL	REFRIGERANT STUB SIZES, IN. [mm]			
	DUAL LIQ.	DUAL SUC.	SINGLE LIQ.	SINGLE SUC.
180	1/2, 1/2 [13, 13]	1 1/8, 1 1/8 [29, 29]	5/8 [16]	1 5/8 [41]
240	5/8, 5/8 [16, 16]	1 3/8, 1 3/8 [35, 35]	7/8 [22]	1 5/8 [41]

MODEL	CORNER WEIGHTS, LBS. [kg]				TOTAL WEIGHT
	A	B	C	D	
180	144 [65]	127 [58]	117 [53]	105 [48]	495 [225]
240	159 [72]	142 [64]	129 [59]	115 [52]	545 [247]

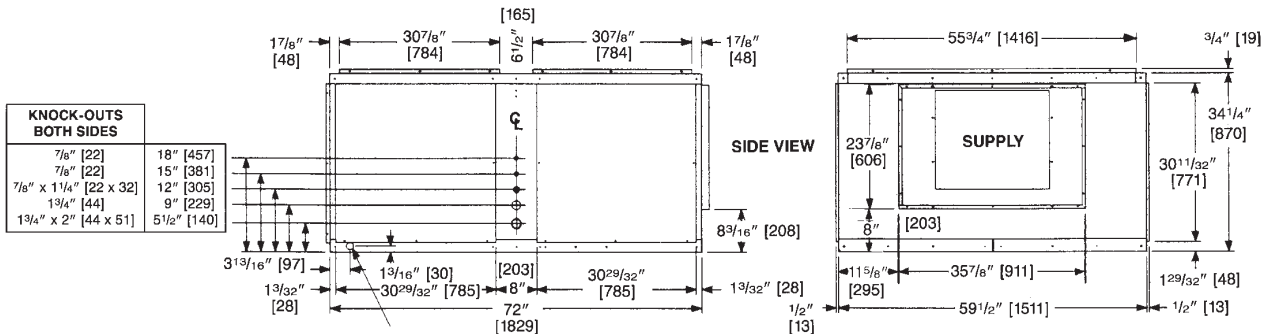

[] Designates Metric Conversions

*Drain connections are provided on both sides of the drain pan. The drain can be connected to either side of the drain pan, but not both. The drain must be trapped.

PHYSICAL DATA/DRIVE PACKAGE DATA—RHGL- SERIES



ITEM		MODEL NO. RHGL-			
		090	120	180	240
Nominal Size tons [kW]		7.5 [26]	10 [35]	15 [53]	20 [70]
Nominal CFM [L/s] @ Rated E.S.P., in. [kPa] of water		3000 @ .25 [1416 @ .062]	3000 @ .25 [1416 @ .062] 4000 @ .30 [1888 @ .075]	6000 @ .35 [2832 @ .087]	8000 @ .40 [3776 @ .099]
MOTOR	Standard—3450 RPM [W] 1 Ø 1725 RPM [W] 3 Ø	1 HP [766] 1 HP [766]	2 HP [1491] 1½ HP [1119]	— 2 HP [1491]	— 5 HP [3729]
	Optional—1725 RPM [W] 3 Ø	1½ HP [1119]	2 HP, 3 HP [1491, 2237]	3 HP, 5 HP [2237, 3729]	7½ HP [5593]
Blower Size—diameter & width, in. [mm]		12 x 12 [305 x 305]	12 x 12 [305 x 305]	18 x 15 [457 x 381]	18 x 18 [457 x 457]
Blower Shaft Size (diameter) in. [mm]		¾ [19]	¾ [19]	1 [25]	1 [25]
Motor Sheave Size 3450 RPM 1 Ø Adjustment (std.) in. [mm] 1725 RPM 3		1.9-2.9 [48-74] 3.4-4.4 [86-112]	2.4-3.2 [61-81] 4.0-5.0 [102-127]	— 3.1-4.1 [79-104]	— 4.3-5.5 [109-140]
Coil Face Area, sq. feet [m²]		10.2 [.95]	10.2 [.95]	16.5 [1.53]	16.5 [1.53]
Coil Tube Diameter in. [mm]		¾ [10]	¾ [10]	¾ [10]	¾ [10]
Coil, Rows Deep—Fins Per Inch [mm]		3/15 [.51]	4/15 [.59]	3/15 [.51]	4/15 [.59]
Refrigerant Control—Thermal Expansion Valves (Quantity)		BBIZE-3-GA (2)	CBBIZE-5-GA (2)	BBIZE-6-GA (2)	BBIZE-8-GA (2)
Filter Size, in. [mm] (Number Required) Disposable*		16 x 25 x 1 (4) [406 x 635 x 25]	16 x 25 x 1 (4) [406 x 635 x 25]	20 x 25 x 1 (6) [508 x 635 x 25]	20 x 25 x 1 (6) [508 x 635 x 25]
CABINET:					
Finish		Powder Paint	Powder Paint	Powder Paint	Powder Paint
Sheet Metal		Galvanized	Galvanized	Galvanized	Galvanized
Gauge (nominal)					
Top		18	18	18	18
Sides		16	16	16	16
Bottom		18	18	16	16
Doors and Covers		20 min.	20 min.	20 min.	20 min.
UNIT WEIGHTS:					
Operating (lbs.) [kg]		330 [150]	347 [157]	495 [225]	545 [247]
Shipping (lbs.) [kg]		350 [159]	367 [166]	530 [240]	580 [263]
PACKAGED DIMENSIONS: (H x W x L) [mm]		31½" x 56" x 57¼" [800 x 1422 x 1454]	31½" x 56" x 57¼" [800 x 1422 x 1454]	39" x 63" x 76½" [991 x 1600 x 1943]	39" x 63" x 76½" [991 x 1600 x 1943]

*Unit will accept 2" [51 mm] filters.

NOTE: If a factory accessory heater kit is not used, a field supplied fan contactor is required and should have a 24 volt coil with contacts rated to handle the evaporator motor FLA at desired voltage. A factory supplied 30 Amp 3 Pole or 30 Amp 2 Pole contactor may be purchased from the Parts Department.

[] Designates Metric Conversions



PHYSICAL DATA/DRIVE PACKAGE DATA—RHGL- SERIES

NOMINAL TONS [kW]	DRIVE PACKAGE — BELT	SHEAVE SELECTIONS*, IN. [mm]			MOTOR HP [W]/PHASE	APPROX. BLOWER RPM @ MOTOR SHEAVE TURNS OPEN							
		MOTOR/BORE	BLOWER			0	1	2	2.5	3	4	5	6
7.5 [26]	K 4L530	3.4-4.4-5/8	[86-112-16]	9.75 [248]	1 [746]/30	790	760	730	715	700	665	630	—
	K 4L480	1.9-2.9	[48-74]	9.75 [248]	1 [746]/10	1025	965	900	—	830	760	695	—
	L 4L530	4.2-5.2-5/8	[107-132-16]	9.75 [248]	1.5 [1119]/30	925	895	860	845	825	790	750	—
	M 4L550	5.2-6.2-5/8	[132-157-16]	9.75 [248]	1.5 [1119]/30	1125	1090	1055	—	1020	985	945	—
	◇N 4L550	5.7-6.7-7/8	[145-170-22]	9.75 [248]	2 [1491]/30	1195	1165	1130	—	1100	1065	1030	—
10 [35]	J+ 4L530	3.4-4.4	[86-112]	9.75 [248]	1.5 [1119]/30	790	760	725	—	690	660	630	—
	K 4L530	4.0-5.0-5/8	[102-127-16]	9.75 [248]	1.5 [1119]/30	885	855	825	—	795	760	730	—
	K 4L480	1.9-2.9	[48-74]	8.75 [222]	2 [1491]/10	1140	1070	995	—	920	845	770	—
	L 4L540	4.6-5.6-7/8	[117-142-22]	9.75 [248]	2 [1491]/30	995	960	930	—	895	860	825	—
	M 4L550	5.2-6.2-7/8	[132-157-22]	9.75 [248]	3 [2237]/30	1125	1090	1055	—	1020	985	945	—
	△N 4L530	4.7-5.7-7/8	[119-145-22]	7.75 [197]	3 [2237]/30	1225	1190	1150	—	1110	1070	1030	—
	□O 4L540	5.7-6.7-7/8	[145-170-22]	8.75 [222]	3 [2237]/30	1280	1250	1220	—	1185	1150	1115	—
15 [53]	K BP-52	3.1-4.1-7/8	[79-104-22]	11.4 [290]	2 [1491]/30	645	620	590	—	565	535	510	480
	L BP-52	3.7-4.7-7/8	[94-119-22]	11.4 [290]	3 [2237]/30	730	705	680	—	655	630	600	570
	M BP-45	3.7-4.7-1 1/8	[94-119-29]	9.4 [239]	5 [3729]/30	870	840	810	—	780	750	715	680
	#N BP-50	4.8-6.0-1 1/8	[122-152-29]	10.4 [264]	5 [3729]/30	985	960	935	—	910	885	860	835
20 [70]	K BP-50	4.3-5.5-1 1/8	[109-140-29]	11.4 [290]	5 [3729]/30	850	825	800	—	775	745	715	685
	L BP-48(2)	4.3-5.5-1 3/8	[109-140-35]	10.4 [264]	7.5 [5593]/30	955	925	895	—	865	835	805	780
	M BP-47(2)	4.3-5.5-1 3/8	[109-140-35]	9.4 [239]	7.5 [5593]/30	1030	995	960	—	925	890	855	815

*Actual pitch diameter in inches. Minimum and maximum pitch diameter shown for adjustable motor sheave. ◇ Field Supplied (Motor Sheave: Browning IVP75, Blower Sheave: Browning AZ100, Motor: 2HP [1491 W], 4 Pole, 30). △ Field Supplied (Motor Sheave: Browning IVP65, Blower Sheave: Browning AZ80). □ Field Supplied (Motor Sheave: Browning IVP75, Blower Sheave: Browning AZ90). # Field Supplied (Motor Sheave: Browning IVP65, Blower Sheave: Browning BK110). + Field Supplied (Motor Sheave: Browning IVP50, Blower Sheave: Browning AZ100). Factory sheave settings are shown in bold print. The K, L, and M drives are available from the factory. The J, N, and O drives are not available from the factory and these sheaves and belts must be field supplied. A motor change is not required. The field supplied sheaves and belts are standard shelf items that are readily available from local equipment supply houses. The chart above gives the necessary specifications for these field supplied sheaves and belts.

[] Designates Metric Conversions



INDOOR BLOWER PERFORMANCE (DRY COIL) RHGL-090 Z/Y

E.S.P.—INCHES OF WATER [kPa]

DRIVE PKG	STD CFM	E.S.P.—INCHES OF WATER [kPa]																								
		.1 [0.02]	.2 [0.05]	.3 [0.07]	.4 [0.10]	.5 [0.12]	.6 [0.15]	.7 [0.17]	.8 [0.20]	.9 [0.22]	1.0 [0.25]	1.1 [0.27]	1.2 [0.30]	1.3 [0.32]	1.4 [0.35]	1.5 [0.37]	1.6 [0.40]	1.7 [0.42]	1.8 [0.45]	1.9 [0.47]	2.0 [0.50]					
		RPM	W	RPM	W	RPM	W	RPM	W	RPM	W	RPM	W	RPM	W	RPM	W	RPM	W	RPM	W	RPM	W			
	1800 [850 L/s]	—	—	—	—	—	—	—	—	—	—	—	—	—	—	—	—	—	—	—	—	—	—			
	2000 [944 L/s]	—	—	—	—	—	—	—	—	—	—	—	—	—	—	—	—	—	—	—	—	—	—			
	2200 [1038 L/s]	—	—	—	—	—	—	—	—	—	—	—	—	—	—	—	—	—	—	—	—	—	—			
	2400 [1133 L/s]	—	—	—	—	—	—	—	—	—	—	—	—	—	—	—	—	—	—	—	—	—	—			
K	2600 [1227 L/s]	—	—	—	—	—	—	—	—	—	—	—	—	—	—	—	—	—	—	—	—	—	—			
L	2800 [1321 L/s]	—	—	—	—	—	—	—	—	—	—	—	—	—	—	—	—	—	—	—	—	—	—			
M	3000 [1416 L/s]	630	660	730	695	775	730	840	770	920	800	995	830	1060	860	1140	890	1220	935	1230	965	1285	995	1345		
N	3200 [1510 L/s]	660	810	695	860	725	920	765	1000	795	1070	825	1140	855	1225	890	1315	920	1370	960	1385	985	1445	1015	1530	
	3400 [1605 L/s]	690	940	725	1000	760	1090	790	1155	820	1225	850	1325	885	1410	915	1460	950	1485	980	1570	1010	1660	1030	1680	
	3600 [1699 L/s]	720	1120	750	1185	790	1250	820	1315	850	1430	885	1520	915	1590	945	1605	975	1695	—	—	—	—	—	—	—

K = IVP50, AZ100, 1 HP [766 W] L = IVP60, AZ100, 1 1/2 HP [1119 W] M = IVP68, AZ100, 1 1/2 [1119 W] HP N = IVP75, AZ100, 2 HP [1491 W] [Field Supplied]
 NOTE: Bold lines separate K, L, M and N drives respectively.

RHGL-090 HK

E.S.P.—INCHES OF WATER [kPa]

DRIVE PKG	STD CFM	E.S.P.—INCHES OF WATER [kPa]																					
		.1 [0.02]	.2 [0.05]	.3 [0.07]	.4 [0.10]	.5 [0.12]	.6 [0.15]	.7 [0.17]	.8 [0.20]	.9 [0.22]	1.0 [0.25]	1.1 [0.27]	1.2 [0.30]	1.3 [0.32]	1.4 [0.35]	1.5 [0.37]	1.6 [0.40]	1.7 [0.42]	1.8 [0.45]	1.9 [0.47]	2.0 [0.50]		
		RPM	W	RPM	W	RPM	W	RPM	W	RPM	W	RPM	W	RPM	W	RPM	W	RPM	W	RPM	W	RPM	W
	2200 [1038 L/s]	—	—	—	—	—	—	—	—	—	—	—	—	—	—	—	—	—	—	—	—	—	—
	2400 [1133 L/s]	—	—	—	—	—	—	—	—	—	—	—	—	—	—	—	—	—	—	—	—	—	—
	2600 [1227 L/s]	—	—	—	—	—	—	—	—	—	—	—	—	—	—	—	—	—	—	—	—	—	—
	2800 [1321 L/s]	—	—	—	—	—	—	—	—	—	—	—	—	—	—	—	—	—	—	—	—	—	—
K	3000 [1416 L/s]	—	—	—	—	—	—	—	—	—	—	—	—	—	—	—	—	—	—	—	—	—	—
	3200 [1510 L/s]	—	—	—	—	—	—	—	—	—	—	—	—	—	—	—	—	—	—	—	—	—	—
	3400 [1605 L/s]	—	—	—	—	—	—	—	—	—	—	—	—	—	—	—	—	—	—	—	—	—	—
	3600 [1699 L/s]	70	1180	750	1290	—	—	—	—	—	—	—	—	—	—	—	—	—	—	—	—	—	—
		4.6	1280	4.1	—	—	—	—	—	—	—	—	—	—	—	—	—	—	—	—	—	—	—

[] Designates Metric Conversions

K = IVP34, AZ100, 1 HP [746 W] 10
 NOTES: T.O. = Turns Open
 1. Standard air @ .075 lbs/ft³
 2. Operation below heavy lines require optional drives.
 3. Motor efficiency = 70
 4. BHP = WATTS x MOTOR EFFICIENCY
 746
 5. BHP = Brake Horsepower
 RPM = Blower Speed

INDOOR BLOWER PERFORMANCE (DRY COIL) RHGL-120 HK

E.S.P.—INCHES OF WATER [kPa]

DRIVE PKG	STD CFM	E.S.P.—INCHES OF WATER [kPa]																			
		.1 [0.02]	.2 [0.05]	.3 [0.07]	.4 [0.10]	.5 [0.12]	.6 [0.15]	.7 [0.17]	.8 [0.20]	.9 [0.22]	1.0 [0.25]	1.1 [0.27]	1.2 [0.30]	1.3 [0.32]	1.4 [0.35]	1.5 [0.37]	1.6 [0.40]	1.7 [0.42]	1.8 [0.45]	1.9 [0.47]	2.0 [0.50]
	3000 [1416 L/s]																				
	3200 [1510 L/s]																				
	3400 [1605 L/s]																				
	3600 [1699 L/s]																				
	3800 [1793 L/s]																				
	4000 [1888 L/s]																				
	4200 [1982 L/s]																				
	4400 [2077 L/s]																				
	4600 [2171 L/s]																				
	4800 [2265 L/s]																				

RHGL-120 Z/Y

E.S.P.—INCHES OF WATER [kPa]

DRIVE PKG	STD CFM	E.S.P.—INCHES OF WATER [kPa]																			
		.1 [0.02]	.2 [0.05]	.3 [0.07]	.4 [0.10]	.5 [0.12]	.6 [0.15]	.7 [0.17]	.8 [0.20]	.9 [0.22]	1.0 [0.25]	1.1 [0.27]	1.2 [0.30]	1.3 [0.32]	1.4 [0.35]	1.5 [0.37]	1.6 [0.40]	1.7 [0.42]	1.8 [0.45]	1.9 [0.47]	2.0 [0.50]
	2400 [1133 L/s]																				
	2600 [1227 L/s]																				
	2800 [1321 L/s]																				
	3000 [1416 L/s]																				
	3200 [1510 L/s]																				
	3400 [1605 L/s]																				
	3600 [1699 L/s]																				
	3800 [1793 L/s]																				
	4000 [1888 L/s]																				
	4200 [1982 L/s]																				
	4400 [2077 L/s]																				
	4600 [2171 L/s]																				
	4800 [2265 L/s]																				
	5000 [2360 L/s]																				

K = IVP34, AZ90, 2 HP [1491 W] 10
 NOTES: T.O. = Turns Open
 1. Standard air @ .075 lbs/ft³
 2. Operation below heavy lines require optional drives.
 3. Motor efficiency = .70
 4. BHP = WATTS x MOTOR EFFICIENCY
 746
 5. BHP = Brake Horsepower
 RPM = Blower Speed

J = IVP50, AZ100, 1 1/2 HP [1119 W] [Field Supplied]
 K = IVP56, AZ100, 1 1/2 HP [1119 W]
 L = IVP62, AZ100, 2 HP [1491 W]
 M = IVP68, AZ100, 3 HP [2237 W]
 N = IVP65, AZ80, 3 HP [2237 W] [Field Supplied]
 O = IVP75, AZ90, 3 HP [2237 W] [Field Supplied]
 NOTE: Bold lines separate J, K, L, M, N and O drives respectively.

[] Designates Metric Conversions



INDOOR BLOWER PERFORMANCE RHGG-15 TON [53 kW] & 20 TON [70 kW] (DRY COIL) RHGL-180 Z/Y

E.S.P.—INCHES OF WATER [kPa]

DRIVE PKG	STD CFM	E.S.P.—INCHES OF WATER [kPa]																																								
		.1 [0.02]	.2 [0.05]	.3 [0.07]	.4 [0.10]	.5 [0.12]	.6 [0.15]	.7 [0.17]	.8 [0.20]	.9 [0.22]	1.0 [0.25]	1.1 [0.27]	1.2 [0.30]	1.3 [0.32]	1.4 [0.35]	1.5 [0.37]	1.6 [0.40]	1.7 [0.42]	1.8 [0.45]	1.9 [0.47]	2.0 [0.50]																					
K	4000 [1888 L/s]	—	—	—	—	—	—	—	—	—	—	—	—	—	—	—	—	—	—	—	—	—																				
	4400 [2077 L/s]	—	—	—	—	—	—	—	—	—	—	—	—	—	—	—	—	—	—	—	—	—																				
	4800 [2266 L/s]	—	—	—	—	—	—	—	—	—	—	—	—	—	—	—	—	—	—	—	—	—																				
	5200 [2454 L/s]	—	—	—	—	—	—	—	—	—	—	—	—	—	—	—	—	—	—	—	—	—																				
L	5600 [2643 L/s]	490	1420	515	1505	540	1620	560	1700	590	1820	610	1905	635	2080	660	2240	680	2365	700	2510	720	2665	740	2740	765	2860	785	2985	805	3105	820	3225	835	3350	850	3490	870	3690	900	3750	
	6000 [2832 L/s]	510	1640	530	1750	560	1860	590	1950	610	2165	630	2270	660	2450	675	2570	695	2725	720	2905	740	2975	765	3100	780	3220	800	3355	815	3480	835	3620	850	3755	865	3865	895	3885	910	4035	
	6400 [3020 L/s]	530	1900	555	1980	590	2255	610	2370	630	2470	665	2660	675	2800	695	2965	720	3180	735	3255	760	3360	775	3485	800	3630	820	3750	830	3890	850	4035	865	4130	890	4150	905	4270	920	4440	
	6800 [3209 L/s]	570	2370	590	2455	610	2575	625	2670	665	2870	675	3030	700	3055	720	3175	740	3350	760	3485	780	3620	800	3750	815	3880	830	4020	845	4160	865	4320	880	4430	905	4595	920	4755	935	4935	
7200 [3398 L/s]	590	2685	610	2800	630	2945	650	3100	680	3195	700	3310	720	3450	745	3610	720	3745	780	3910	800	4040	820	4230	830	4345	845	4470	865	4630	890	4790	905	4985	920	5150	—	—	—	—	—	—

K = IVP44, BK120, 2 HP [1491 W]
 L = IVP50, BK120, 3 HP [2237 W]
 M = IVP50, BK100, 5 HP [3729 W]
 N = IVP65, BK110, 5 HP [3729 W] [Field Supplied]
 NOTE: Bold lines separate K, L, M and N drives respectively.

RHGL-240 Z/Y

E.S.P.—INCHES OF WATER [kPa]

DRIVE PKG	STD CFM	E.S.P.—INCHES OF WATER [kPa]																																													
		.1 [0.02]	.2 [0.05]	.3 [0.07]	.4 [0.10]	.5 [0.12]	.6 [0.15]	.7 [0.17]	.8 [0.20]	.9 [0.22]	1.0 [0.25]	1.1 [0.27]	1.2 [0.30]	1.3 [0.32]	1.4 [0.35]	1.5 [0.37]	1.6 [0.40]	1.7 [0.42]	1.8 [0.45]	1.9 [0.47]	2.0 [0.50]																										
K	6000 [2832 L/s]	—	—	—	—	—	—	—	—	—	—	—	—	—	—	—	—	—	—	—	—	—	—	—	—	—	—	—	—	—	—	—	—	—	—	—	—	—	—	—	—	—	—				
	6500 [3068 L/s]	—	—	—	—	—	—	—	—	—	—	—	—	—	—	—	—	—	—	—	—	—	—	—	—	—	—	—	—	—	—	—	—	—	—	—	—	—	—	—	—	—	—				
	7000 [3304 L/s]	—	—	—	—	—	—	—	—	—	—	—	—	—	—	—	—	—	—	—	—	—	—	—	—	—	—	—	—	—	—	—	—	—	—	—	—	—	—	—	—	—	—	—			
	7500 [3540 L/s]	—	—	—	—	—	—	—	—	—	—	—	—	—	—	—	—	—	—	—	—	—	—	—	—	—	—	—	—	—	—	—	—	—	—	—	—	—	—	—	—	—	—	—	—		
L-M	8000 [3776 L/s]	—	—	—	—	—	—	—	—	—	—	—	—	—	—	—	—	—	—	—	—	—	—	—	—	—	—	—	—	—	—	—	—	—	—	—	—	—	—	—	—	—	—	—	—		
	8500 [4012 L/s]	—	—	—	—	—	—	—	—	—	—	—	—	—	—	—	—	—	—	—	—	—	—	—	—	—	—	—	—	—	—	—	—	—	—	—	—	—	—	—	—	—	—	—	—		
	9000 [4248 L/s]	685	4070	700	4240	720	4440	735	4615	760	4790	780	4995	815	5165	830	5300	865	5570	880	5720	895	5860	910	6060	925	6170	940	6370	955	6660	975	6860	990	7040	1010	7240	1025	7500	—	—	—	—	—			
	9500 [4484 L/s]	700	4730	720	4940	785	5325	800	5500	820	5670	835	5790	850	5920	865	6060	880	6210	895	6370	905	6530	925	6700	940	6850	950	7140	965	7335	985	7520	—	—	—	—	—	—	—	—	—	—	—	—		
10000 [4719 L/s]	805	6080	815	6145	830	6470	840	6615	860	6720	870	6890	885	7040	900	7220	915	7430	925	7600	990	7600	—	—	—	—	—	—	—	—	—	—	—	—	—	—	—	—	—	—	—	—	—	—	—	—	—

K = IVP60, BK120, 5 HP [3729 W]
 L = IVP60, BK110, 7 1/2 HP [5593 W]
 M = IVP60, BK100, 7 1/2 HP [5593 W]
 NOTES: 1. Bold lines separate K, L and M drives respectively.
 2. Standard air @ .075 lbs./ft³ [m³]
 3. Operation below heavy lines require optional drives.
 4. Motor efficiency = .85
 5. BHP = WATTS x MOTOR EFFICIENCY / 746
 6. BHP = Brake Horsepower
 RPM = Blower Speed

[] Designates Metric Conversions



COMPONENT AIR RESISTANCE

RHGL 7.5 TON [26 kW] & 10 TON [35 kW]

CFM [L/s]	1800 [850]	2200 [1038]	2600 [1227]	3000 [1416]	3400 [1605]	3800 [1793]	4200 [1982]	4600 [2171]	5000 [2360]
Electric Heater 20KW, 30KW	.060 [.015]	.100 [.025]	.140 [.034]	.160 [.040]	.230 [.057]	.320 [.080]	.410 [.102]	.500 [.124]	.600 [.150]
Mixing Box (R/A Damper Open)	.006 [.001]	.008 [.002]	.012 [.003]	.024 [.006]	.038 [.009]	.053 [.013]	.068 [.017]	.080 [.020]	.095 [.024]
Discharge Grille (Set Max. Open)	.008 [.002]	.011 [.003]	.015 [.004]	.020 [.005]	.025 [.006]	.031 [.008]	.039 [.010]	.046 [.012]	.055 [.014]
Inlet Grille	.008 [.002]	.010 [.002]	.014 [.003]	.020 [.005]	.026 [.006]	.032 [.008]	.039 [.010]	.049 [.012]	.058 [.014]
Discharge Plenum	.02 [.005]	.04 [.010]	.05 [.012]	.065 [.016]	.085 [.021]	.100 [.025]	.120 [.030]	.150 [.037]	.180 [.045]

RHGL 15 TON [53 kW]

CFM [L/s]	4000 [1888]	4400 [2077]	4800 [2265]	5200 [2454]	5600 [2643]	6000 [2832]	6400 [3020]	6800 [3209]	7200 [3398]
Electric Heater 30KW	.175 [.040]	.187 [.050]	.200 [.049]	.215 [.053]	.230 [.057]	.250 [.062]	.275 [.068]	.305 [.076]	.350 [.087]
Electric Heater 40KW	.290 [.070]	.320 [.080]	.350 [.087]	.380 [.095]	.410 [.102]	.450 [.112]	.495 [.123]	.550 [.137]	.600 [.149]
Mixing Box (R/A Damper Open)	.030 [.007]	.037 [.009]	.044 [.011]	.052 [.013]	.061 [.015]	.071 [.018]	.091 [.023]	.102 [.025]	.110 [.027]
Discharge Grille (Set Max. Open)	.010 [.003]	.012 [.003]	.014 [.004]	.017 [.004]	.019 [.005]	.022 [.006]	.025 [.006]	.029 [.007]	.032 [.008]
Inlet Grille	.010 [.002]	.014 [.003]	.020 [.005]	.027 [.007]	.035 [.009]	.044 [.011]	.054 [.013]	.065 [.016]	.077 [.019]
Discharge Plenum	.02 [.005]	.04 [.010]	.05 [.012]	.065 [.012]	.085 [.021]	.100 [.025]	.120 [.030]	.150 [.037]	.180 [.045]

RHGL 20 TON [70 kW]

CFM [L/s]	6400 [3020]	6800 [3209]	7200 [3398]	7600 [3586]	8000 [3776]	8400 [3964]	8800 [4153]	9200 [4342]	9600 [4531]
Electric Heater 30KW	.220 [.055]	.230 [.057]	.240 [.060]	.260 [.065]	.280 [.070]	.300 [.075]	.320 [.080]	.340 [.085]	.370 [.092]
Electric Heater 40KW	.360 [.090]	.390 [.097]	.420 [.104]	.450 [.112]	.490 [.122]	.530 [.132]	.570 [.142]	.610 [.152]	.650 [.162]
Mixing Box (R/A Damper Open)	.095 [.023]	.102 [.025]	.110 [.027]	.115 [.030]	.121 [.030]	.126 [.031]	.128 [.032]	.135 [.034]	.142 [.035]
Discharge Grille (Set Max. Open)	.025 [.006]	.029 [.007]	.032 [.008]	.036 [.009]	.040 [.010]	.044 [.011]	.048 [.012]	.053 [.013]	.057 [.014]
Inlet Grille	.054 [.013]	.065 [.016]	.077 [.019]	.090 [.022]	.104 [.026]	.120 [.030]	.150 [.037]	.190 [.047]	.240 [.060]
Discharge Plenum	.120 [.030]	.150 [.037]	.180 [.045]	.210 [.052]	.250 [.062]	.290 [.072]	.340 [.085]	.400 [.010]	.470 [.117]

NOTE: Add component resistance to duct resistance to determine total E.S.P.

BLOWER PERFORMANCE CURVES—7.5 TON [26 kW] (WET COIL)

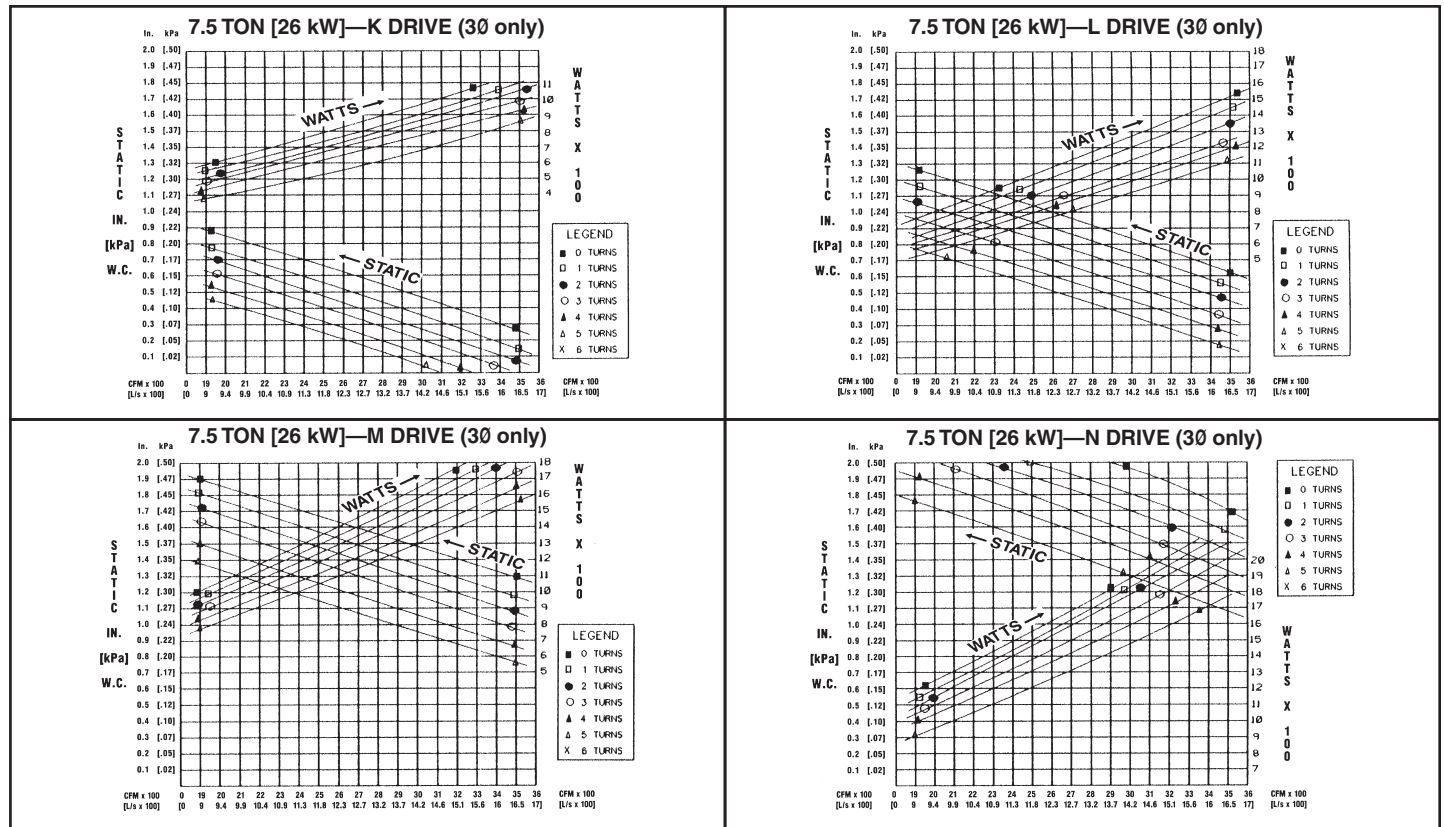

[] Designates Metric Conversions



BLOWER PERFORMANCE CURVES—10 TON [35 kW] (WET COIL)

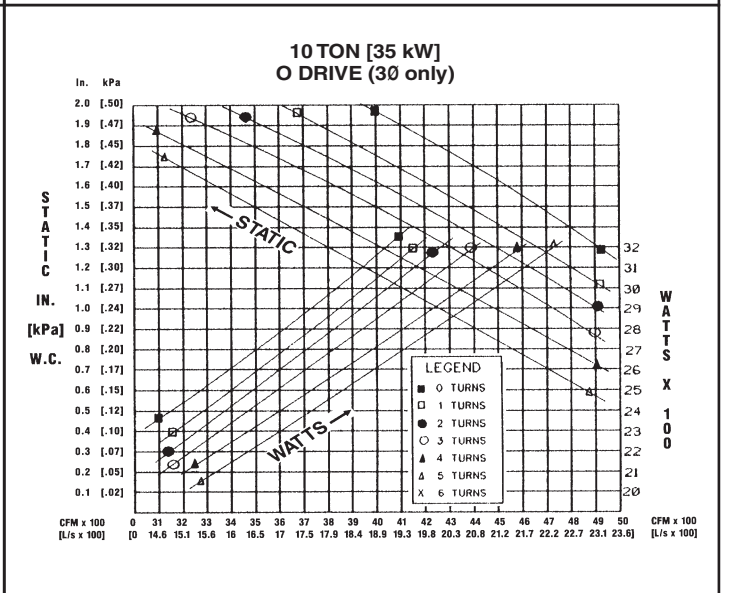
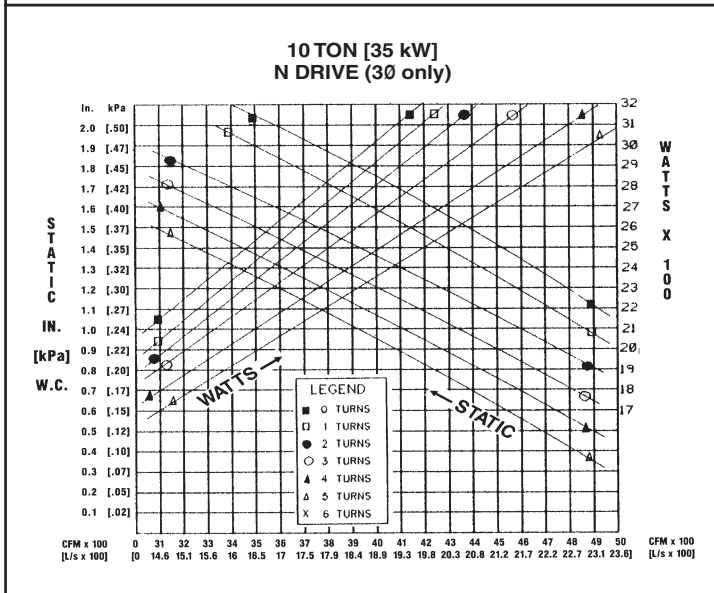
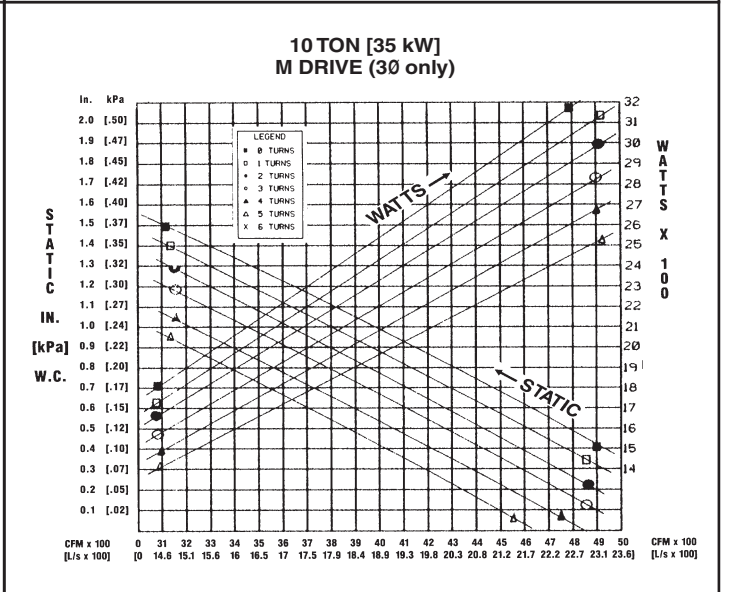
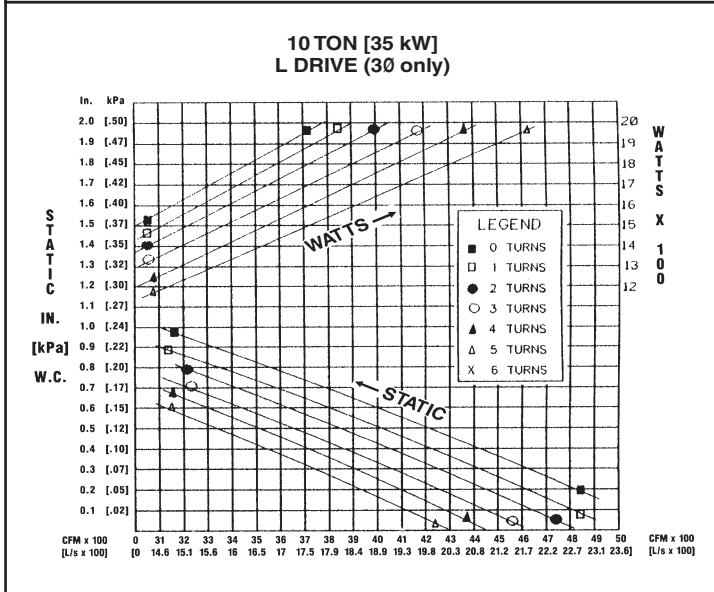
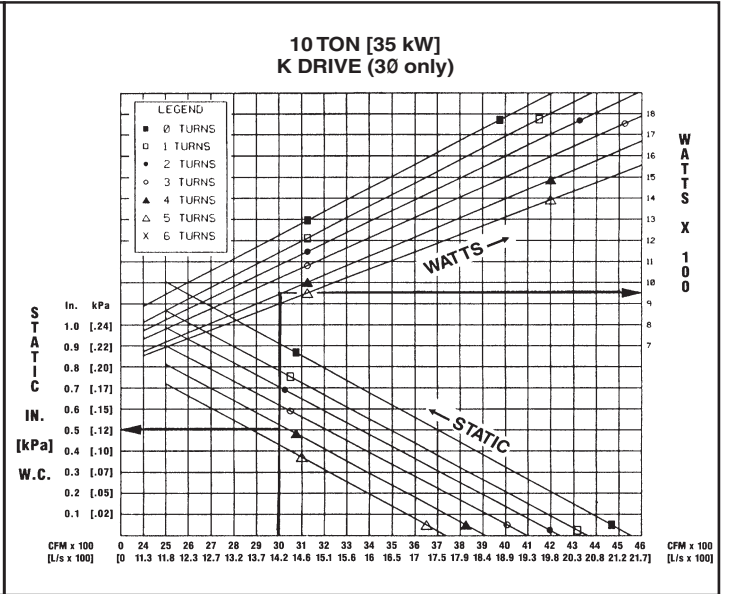
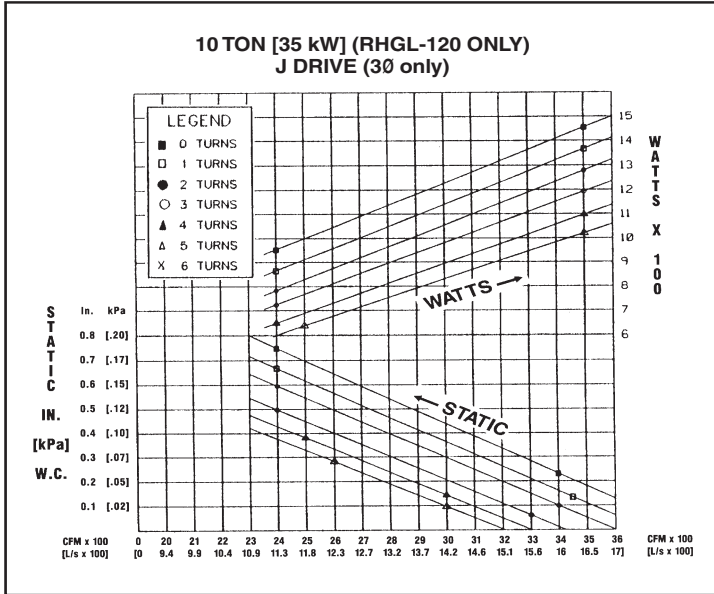

[] Designates Metric Conversions



EVAPORATOR PERFORMANCE DATA (GROSS CAPACITY)

EVAPORATOR/AIR HANDLER RHGL-090 @ 3000 CFM [1416 L/s] 105°F (40.8°C) LIQUID TEMPERATURE AT TXV													
AIRFLOW	EVAP. TEMP	75/63°F				80/67°F				55/71°F			
		TC	SC	LDB °F	LWB °F	TC	SC	LDB °F	LWB °F	TC	SC	LDB °F	LWB °F
3000	40	101,593	73,674	52.9	51.0	127,358	84,666	63.8	51.9	153,992	94,880	54.9	53.1
	45	80,928	62,952	57.3	54.8	103,594	73,170	58.8	56.3	130,995	83,959	59.4	57.3
	50	59,031	52,456	61.6	66.7	80,997	82,400	63.0	50.2	105,321	72,678	64.1	61.6

EVAPORATOR/AIR HANDLER RHGL-120 @ 3800 CFM [1793 L/s] 105°F (40.6°C) LIQUID TEMPERATURE AT TXV													
AIRFLOW	EVAP. TEMP	75/63°F				80/67°F				85/71°F			
		TC	SC	LDB °F	LWB °F	TC	SC	LDB °F	LWB °F	TC	SC	LDB °F	LWB °F
3800	40	154,071	108,420	49.6	48.2	190,237	123,295	50.5	48.1	189,959	10,8803	60.4	58.6
	45	121,745	92,384	54.1	52.3	157,209	107,660	66.0	53.4	196,257	122,470	55.9	54.3
	50	88,849	77,108	58.5	56.3	122,773	91,908	59.5	57.5	159,969	108,803	60.4	56.6

EVAPORATOR/AIR HANDLER RHGL-180 @ 6000 CFM [2832 L/s] 105°F (40.6°C) LIQUID TEMPERATURE AT TXV													
AIRFLOW	EVAP. TEMP	75/63°F				80/67°F				85/71°F			
		TC	SC	LDB °F	LWB °F	TC	SC	LDB °F	LWB °F	TC	SC	LDB °F	LWB °F
6000	40	189,115	142,220	53.1	51.7	235,654	162,761	54.9	53.7	286,314	182,615	56.8	55.6
	45	149,290	121,287	56.3	54.3	192,102	141,102	58.2	56.4	240,876	161,094	60.1	58.4
	50	109,437	102,323	59.2	56.7	149,227	120,400	61.4	59.0	194,559	139,871	63.4	61.0

EVAPORATOR/AIR HANDLER RHGL-240 @ 8000 CFM [3776 L/s] 105°F (40.6°C) LIQUID TEMPERATURE AT TXV													
AIRFLOW	EVAP. TEMP	75/63°F				80/67°F				85/71°F			
		TC	SC	LDB °F	LWB °F	TC	SC	LDB °F	LWB °F	TC	SC	LDB °F	LWB °F
8000	40	254,328	189,910	53.0	51.6	315,853	187,796	58.3	53.6	378,360	240,448	57.2	55.7
	45	200,864	162,132	56.2	54.2	256,712	216,298	55.0	56.4	324,947	214,800	60.1	58.2
	50	148,684	136,787	59.2	56.6	202,098	162,261	61.2	58.9	260,278	186,284	63.4	61.0

NOTES: 1. Total and sensible capacity is gross with no deduction for indoor blower motor heat. 2. Interpolation is permissible. Do not extrapolate.
 3. Capacities are based on 105°F (40.6°C) liquid temperature at the TXV or about 95°F (35°C) dry bulb outdoor ambient.
 TC = Total Capacity, BTUH LDB = Leaving Air Dry Bulb
 SC = Sensible Capacity, BTUH LWB = Leaving Air Wet Bulb

[] Designates Metric Conversions



AIRFLOW CORRECTION FACTORS

RHGL-090 @ 3000 CFM [1416 L/s]							
ACTUAL—CFM [L/s]	2400 [1133]	2600 [1227]	2800 [1321]	3000 [1416]	3200 [1510]	3400 [1605]	3600 [1699]
TOTAL MBH	0.85	0.90	0.95	1.00	1.04	1.09	1.13
SENSIBLE MBH	0.83	0.88	0.94	1.00	1.06	1.11	1.16

NOTES: 1. Multiply correction factor times gross performance data.
2. Resulting sensible capacity cannot exceed total capacity.

RHGL-120 @ 3800 CFM [1793 L/s]													
ACTUAL—CFM [L/s]	2400 [1133]	2600 [1227]	2800 [1321]	3000 [1416]	3200 [1510]	3400 [1605]	3600 [1699]	3800 [1793]	4000 [1888]	4200 [1982]	4400 [2077]	4600 [2171]	4800 [2265]
TOTAL MBH	0.76	0.79	0.82	0.85	0.89	0.93	0.97	1.00	1.03	1.06	1.10	1.12	1.15
SENSIBLE MBH	0.68	0.73	0.78	0.82	0.87	0.91	0.96	1.00	1.04	1.08	1.13	1.17	1.21

NOTES: 1. Multiply correction factor times gross performance data.
2. Resulting sensible capacity cannot exceed total capacity.

RHGL-180 @ 6000 CFM [2832 L/s]										RHGL-240 @ 8000 CFM [3776 L/s]									
ACTUAL—CFM [L/s]	4400 [2077]	4800 [2265]	5200 [2454]	5600 [2643]	6000 [2832]	6400 [3020]	6800 [3209]	7200 [3398]	7600 [3587]	6400 [3020]	6800 [3209]	7200 [3398]	7600 [3587]	8000 [3776]	8400 [3964]	8800 [4153]	9200 [4342]	9600 [4531]	
TOTAL MBH	0.83	0.88	0.92	0.96	1.00	1.04	1.07	1.10	1.13	0.88	0.91	0.94	0.97	1.00	1.03	1.05	1.07	1.09	
SENSIBLE MBH	0.78	0.84	0.89	0.95	1.00	1.05	1.10	1.15	1.20	0.84	0.88	0.92	0.96	1.00	1.04	1.08	1.11	1.15	

NOTES: 1. Multiply correction factor times gross performance data.
2. Resulting sensible capacity cannot exceed total capacity.

[] Designates Metric Conversions



PERFORMANCE DATA/ELECTRIC HEATER KITS—RHGL- SERIES

PERFORMANCE DATA @ AHRI STANDARD CONDITIONS—COOLING

Dual Condensing Unit with Air Handler

OUTDOOR UNIT & AIR HANDLER	NET TOTAL	NET SENSIBLE	NET LATENT	EER	INDOOR AIRFLOW, CFM	A/H WATTS	TOTAL WATTS	DO WATTS	COMP WATTS	FAN WATTS
	BTU/H [kW]	BTU/H [kW]	BTU/H [kW]							
RANL-036 +RHGL -090	76,000 [22.27]	55,000 [16.12]	21,000 [6.18]	11.60	2,400 [1133]	510	8,552	6,042	5,512	530
RANL-048 +RHGL -090	94,000 [27.54]	71,000 [20.80]	23,000 [6.74]	11.60	3,200 [1510]	1,000	8,103	7,103	6,643	460
RANL-048 +RHGL -120	97,000 [28.42]	74,000 [21.66]	23,000 [6.74]	11.90	3,200 [1510]	1,000	8,151	7,145	8,885	460
RAPL-060JA +RHGL -120	110,000 [33.99]	86,000 [25.20]	30,000 [8.79]	11.20	4,000 [1888]	1,780	10,357	8,577	8,117	460

ELECTRIC HEATER KIT CHARACTERISTICS

AIR HANDLER MODEL	HEATER KIT MODEL	HEATER KIT VOLTAGE	HEATER KIT [kW]	HEATER KIT AMPS	HEATING CAPACITY [kW]	HEATING CAPACITY MBH	MINIMUM CIRCUIT AMPACITY	MAX. FUSE OR HACR BREAKER SIZE
RHGL-090 / RHGL-120	RXHE-DE020CA	208/240	20	43.1/48.9	15.6/20.2	53.2/68.9	67/73	70/80
RHGL-090 / RHGL-120	RXHE-DE030CA	208/240	30	60.8/70.2	22.0/29.6	75.1/101	89/100	90/100
RHGL-090 / RHGL-120	RXHE-DE020DA	480	20	24.7	20.2	68.9	37	40
RHGL-090 / RHGL-120	RXHE-DE030DA	480	30	35	29.7	101.3	50	50
RHGL-180 / RHGL-240	RXHE-CE030CC	208/240	30	60/70	21.6/28.8	73.7/98.3	105/115	110/125
RHGL-180 / RHGL-240	RXHE-CE040CC	208/240	40	83/96	30/40	102.4/136.5	134/148	150/150
RHGL-180 / RHGL-240	RXHE-CE030DC	480	30	35	28.8	98.3	58	60
RHGL-180 / RHGL-240	RXHE-CE040DC	480	40	48	40	136.5	74	80

NOTE: All kits have two stages of capacity, first stage heating is 50% of total capacity.

ELECTRICAL DATA TABLE

AIR HANDLER MOTOR			RATING PLATE AMPS	MOTOR LRA	MINIMUM CIRCUIT AMPACITY	RECOMMENDED MINIMUM Cu WIRE SIZE (3% VOLTAGE 75°C DROP) MAX. RUN IN FEET	MAX. FUSES BREAKERS
HP [W]	VOLTS	PHASE					
1 [746]	208-230	30	4.0/3.6	23.9/21.6	15	#14/240	15
1 [746]	460	30	1.8	10.8	15	#14/400	15
1 [746]	575	30	1.4	8.4	15	#14/425	15
1 [746]	115-230	10	16/8	96/48	20/15	#12/120 #14/180	20/15
1 1/2 [1119]	208-230	30	5.7/5.2	34.5/31.2	15	#14/230	15
1 1/2 [1119]	460	30	2.6	15.6	15	#14/300	15
1 1/2 [1119]	575	30	2.1	12.6	15	#14/325	15
2 [1491]	208-230	30	7.5/6.8	45.1/40.8	15	#14/165	15
2 [1491]	460	30	3.4	20.4	15	#14/275	15
2 [1491]	575	30	2.7	16.2	15	#14/300	15
2 [1491]	115-230	10	24/12	144/72	30/15	#10/140 #14/120	30/15
3 [2237]	208-230	30	10.6/9.6	64.1/58	15	#14/135	15
3 [2237]	460	30	4.8	26.8	15	#14/230	15
3 [2237]	575	30	3.9	23.4	15	#14/240	15
5 [3729]	208-230	30	16.7/15.2	100.6/91	21/19	#10/240 #12/150	25/20
5 [3729]	460	30	7.6	45.6	15	#14/185	15
5 [3729]	575	30	6.1	36.6	15	#14/220	15
7 1/2 [5593]	208-230	30	24.2/22.0	146/132	30/28	#10/150	30/30
7 1/2 [5593]	460	30	11.0	66	15	#14/135	15
7 1/2 [5593]	575	30	9.0	54	15	#14/150	15

NOTE: N.E.C., C.E.C. and local codes take precedence over suggested wire and fuse sizes.

[] Designates Metric Conversions

OPTIONAL HEATER KIT

COMPONENT CODE

- BC BLOWER CONTACTOR
- HC HEATER CONTACTOR
- LBR LIMIT BYPASS RELAY
- LC LIMIT CONTROL

WIRE COLOR CODE

- | | |
|-----------|-----------|
| BK BLACK | PU PURPLE |
| BR BROWN | RD RED |
| BU BLUE | WH WHITE |
| GR GREEN | YL YELLOW |
| OR ORANGE | |

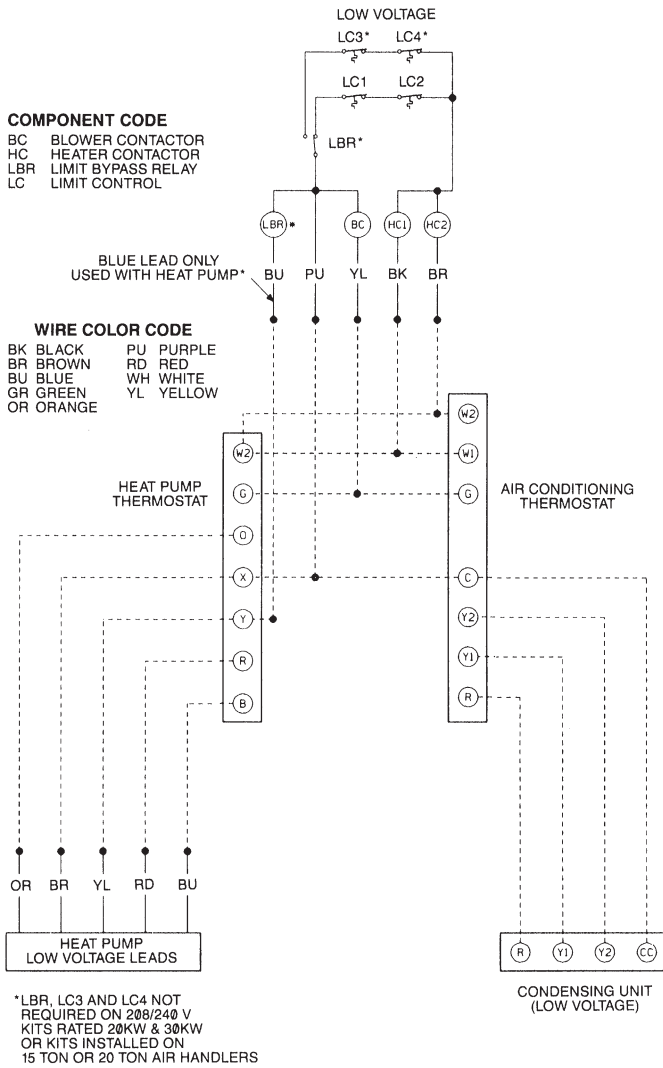

TYPICAL WIRING CONNECTIONS WITH DUAL CIRCUIT AIR HANDLER, ELECTRIC HEAT & TWO CONDENSING UNITS

120-208-230-460 VOLT AS REQUIRED

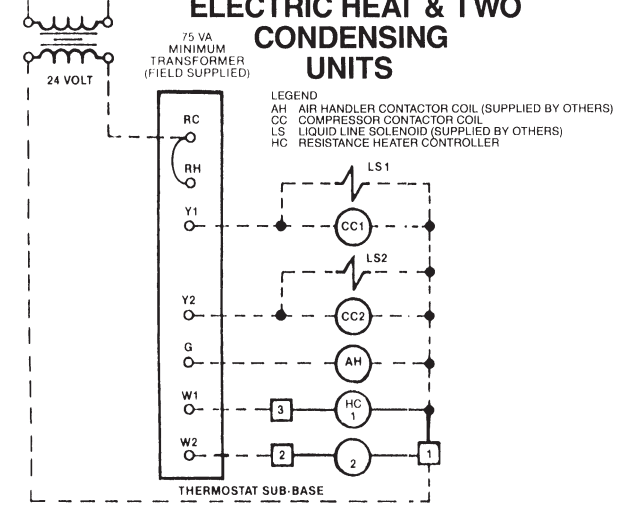

POWER WIRING

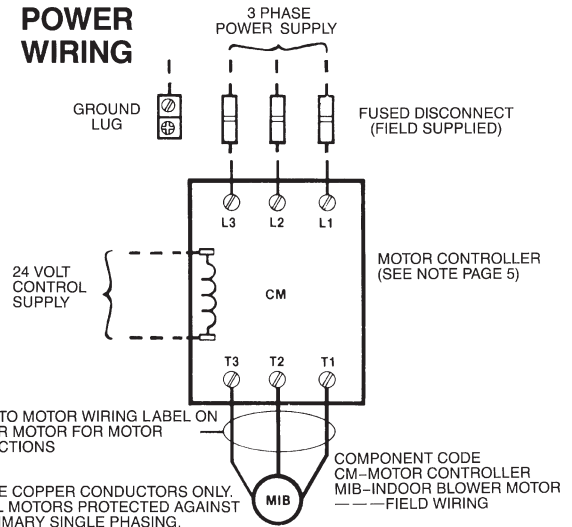

AIR HANDLER ACCESSORIES

ACCESSORY DESCRIPTION	MODEL NUMBER	SIZES USED ON	NET WEIGHT (LBS) [kg]
Hot Water Coil	RXHC-C74W	090, 120	200 [91]
	RXHC-C76W	180, 240	200 [91]
Steam Coil	RXHC-C74S	090, 120	200 [91]
	RXHC-C76S	180, 240	200 [91]
Filter Frame Kit	RXHF-B74A	090, 120	90 [41]
	RXHF-B76A	180, 240	117 [53]
Inlet Grille Kit	RXHG-C74A	090, 120	9 [4]
	RXHG-C76A	180, 240	12 [5]
Discharge Grille Kit	RXHG-C74B	090, 120	15 [7]
	RXHG-C76B	180, 240	23 [10]
Discharge Plenum Kit	RXHL-C74B	090, 120	38 [17]
	RXHL-C76B	180, 240	62 [28]
Mixing Box	RXHM-BC74H	090, 120	120 [54]
	RXHM-BC76H	180, 240	195 [88]
Auxiliary Heater Kit	RXHE-DE020*A	090, 120	75 [34]
	RXHE-DE030*A	090, 120	75 [34]
	RXHE-CE030*C	180, 240	90 [41]
	RXHE-CE040*C	180, 240	98 [44]

NOTE: *Designates "C", "D" or "Y" Voltage

[] Designates Metric Conversions

RXHM MIXING BOX



RXHE ELECTRIC HEATER KIT



HOT WATER OR STEAM COILS

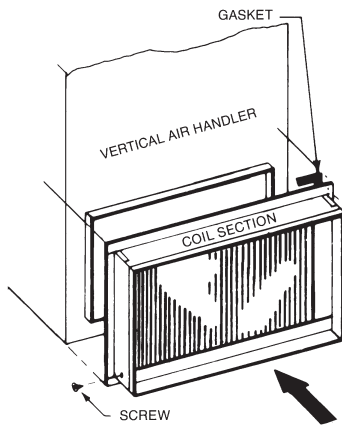

(090, 120) RXHC-C74W
RXHC-C74S
or
(180, 240) RXHC-C76W
RXHC-C76S

(090, 120) RXHC-C74W
RXHC-C74S
or
(180, 240) RXHC-C76W
RXHC-C76S

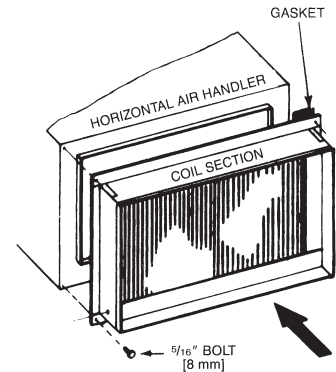

AIR HANDLER ACCESSORIES (con't)

PHYSICAL SPECIFICATIONS

NOMINAL TONS [kW]	FINNED HEIGHT—IN. [mm]	FINNED LENGTH—IN. [mm]	FACE AREA FT ² [m ²]	CIRCUITS & TUBES HIGH
7½ [26.38]-10 [35.17]	18 [457]	40 [1016]	5.0 [.46]	12
15 [52.75]-20 [70.34]	27 [686]	48 [1219]	9.0 [.84]	18

GROSS COIL PERFORMANCE

NOMINAL TONS [kW]	NOMINAL BTUH		NOMINAL CFM [L/s]	VELOCITY FPM
	STEAM	WATER		
7½ [26.38]	242,500	185,000	3,000 [1416]	600
10 [35.17]	285,000	240,000	4,000 [1888]	800
15 [52.75]	465,000	375,000	6,000 [2832]	667
20 [70.34]	540,000	464,000	8,000 [3776]	888

1. Entering air temperature @ 60°F
2. Entering steam @ 5 PSIG
3. Entering water @ 200°F
4. Face velocity = $\frac{\text{CFM}}{\text{Face Area}}$

STEAM COIL

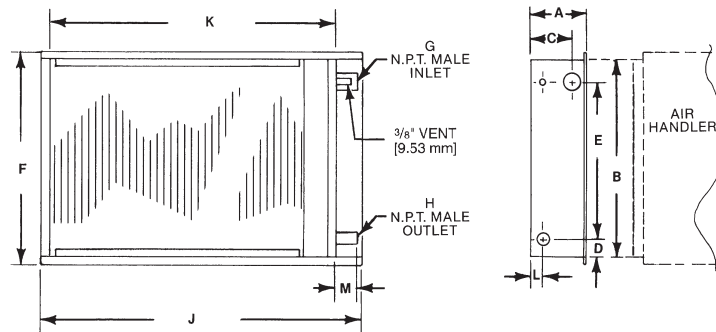

STEAM COIL COIL DIMENSIONS—INCHES [mm]

MODEL	NOMINAL TONS [kW]	A	B	C	D	E	F	G	H	J	K	L	M
RXHC-C74	7½ [26.38]-10 [35.17]	9 ¹ / ₁₆ [230]	21 ³ / ₈ [543]	5 ³ / ₈ [137]	3 ³ / ₁₆ [81]	15 [381]	24 [610]	1 ¹ / ₂ [38]	1 ¹ / ₄ [32]	51 ¹ / ₂ [1308]	47 ⁵ / ₈ [1210]	2 ¹³ / ₁₆ [71]	3 ¹ / ₄ [83]
RXHC-C76S	15 [52.75]-20 [70.34]	9 ¹ / ₁₆ [230]	30 ⁷ / ₈ [784]	5 ³ / ₈ [137]	3 ³ / ₁₆ [81]	24 [610]	35 [889]	2 [51]	1 ¹ / ₂ [38]	59 ¹ / ₂ [1511]	55 ⁵ / ₈ [1413]	2 ¹³ / ₁₆ [71]	3 ¹ / ₂ [89]

HOT WATER COIL

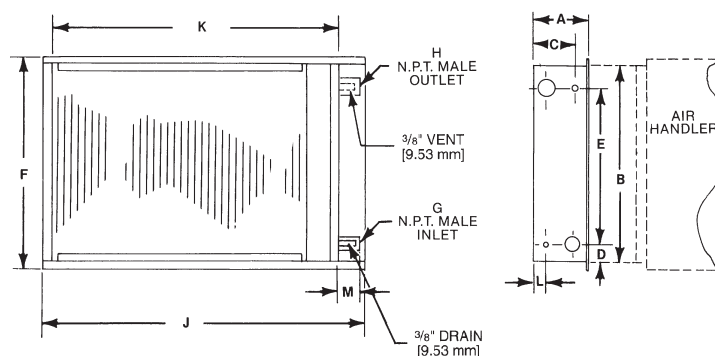

HOT WATER COIL DIMENSIONS—INCHES [mm]

MODEL	NOMINAL TONS [kW]	A	B	C	D	E	F	G	H	J	K	L	M
RXHC-C74W	7½ [26.38]-10 [35.17]	9 ¹ / ₁₆ [230]	21 ³ / ₈ [543]	5 ³ / ₈ [137]	3 ³ / ₁₆ [81]	15 [381]	24 [610]	1 ¹ / ₂ [32]	1 ¹ / ₄ [32]	51 ¹ / ₂ [1308]	47 ⁵ / ₈ [1210]	2 ¹³ / ₁₆ [71]	3 [76]
RXHC-C76W	15 [52.75]-20 [70.34]	9 ¹ / ₁₆ [230]	30 ⁷ / ₈ [784]	5 ³ / ₈ [137]	3 ³ / ₁₆ [81]	24 [610]	35 [889]	1 ¹ / ₂ [38]	1 ¹ / ₂ [38]	59 ¹ / ₂ [1511]	55 ⁵ / ₈ [1413]	2 ¹³ / ₁₆ [71]	3 ¹ / ₄ [83]

[] Designates Metric Conversions



AIR HANDLER ACCESSORIES (con't)
HOT WATER COILS

**CURVE 2
HOT WATER COIL**

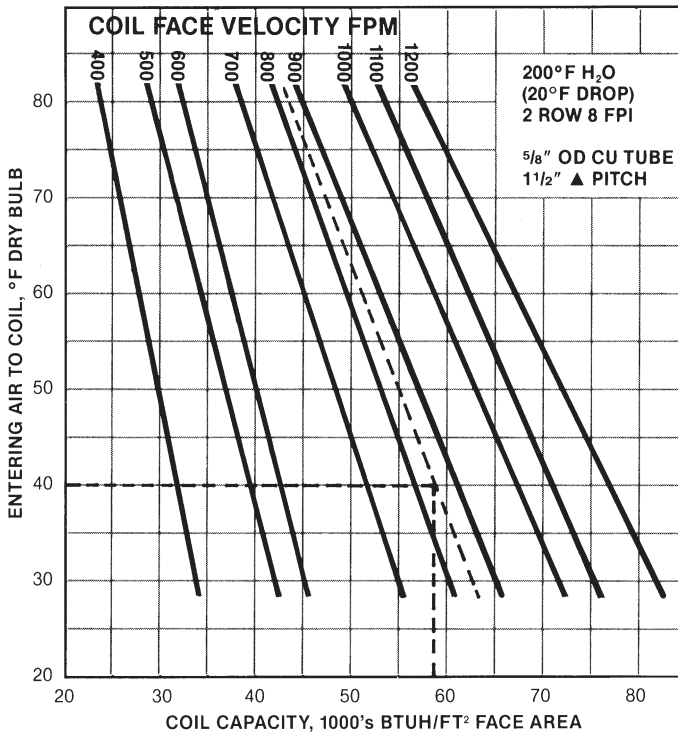

**CURVE 3
HOT WATER COIL WATER
PRESSURE DROP**

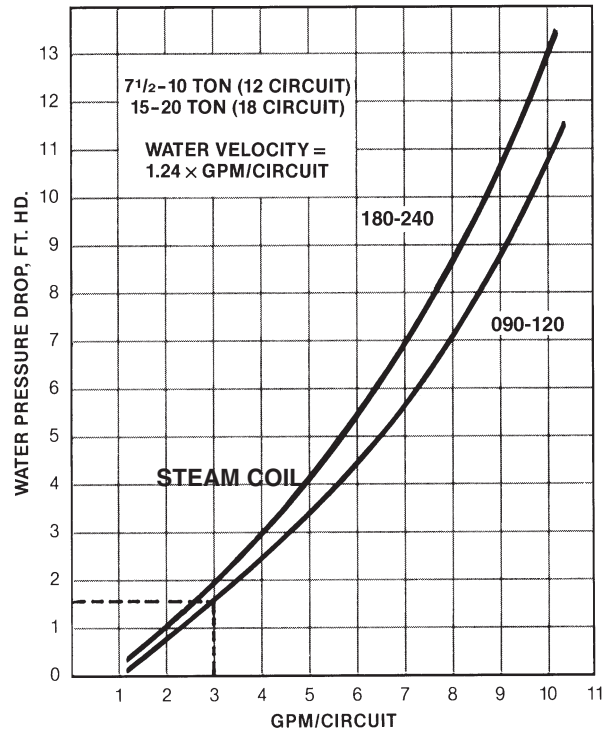

TABLE IV

Curve 2 ratings are based on 200°F entering water and 20°F temperature drop. For other conditions use the following correction factors:

ENTERING WATER °F	FACTOR	WATER TEMPERATURE DROP °F	FACTOR
220	1.14	10	1.030
210	1.07	15	1.015
200	1.00	20	1.000
190	.98	25	.985
180	.93	30	.970

BASIC FORMULA:

$$\text{Air Temperature Rise, } ^\circ\text{F} = \frac{\text{BTUH}}{1.08 \times \text{CFM}}$$

$$\text{Water Temperature Drop, } ^\circ\text{F} = \frac{\text{BTUH}}{500 \times \text{GPM}}$$

HOT WATER COIL SELECTION:

Specified:

Entering Air Temp. @ 40°F
5000 CFM @ 6000 Ft. Elevation
220°F Entering Water Temp. @ 36 GPM

Select 10 Ton Nominal Coil:

Face Area = 5 Ft²
Circuits = 12

Determine Coil Performance:

From Table I, Altitude and Temperature Correction Factor = 1.19 Std. CFM = 5000/1.19 = 4202
Face Velocity = 4202/5 = 840 FPM
From Curve 2, BTUH/Ft² = 57,500
Coil Capacity = 5 x 58,000 = 287,500 BTUH
Water Temp. Drop = 290,000/(500 x 36) = 16.1°F
From Table IV, Water Temp. Factor = 1.14
From Table IV, Water Temp. Drop Factor = 1.012
Total Capacity = 287,500 x 1.14 x 1.015 = 334,570 BTUH
From Curve 3, Water Pressure Drop 36 GPM/12 Circuits = 3 GPM/Circuit = 1.6 FT. HD.
From Table II, Air Side Pressure Drop = .38" H₂O



AIR HANDLER ACCESSORIES (con't) STEAM COILS AIRFLOW

**TABLE I
ALTITUDE AND TEMPERATURE CORRECTION FACTOR TABLE**

AIR TEMP. (F)	ALTITUDE IN FEET ABOVE SEA LEVEL															
	0	500	1000	1500	2000	2500	3000	3500	4000	4500	5000	6000	7000	8000	9000	10,000
0	.87	.89	.91	.92	.94	.96	.98	.99	1.01	1.03	1.05	1.09	1.13	1.17	1.22	1.26
40	.94	.96	.98	1.00	1.02	1.04	1.06	1.08	1.10	1.12	1.14	1.19	1.23	1.28	1.32	1.36
70	1.00	1.02	1.04	1.06	1.08	1.10	1.12	1.14	1.19	1.18	1.20	1.25	1.30	1.35	1.40	1.45
100	1.06	1.08	1.10	1.12	1.14	1.16	1.19	1.21	1.23	1.25	1.28	1.33	1.38	1.43	1.48	1.54
120	1.09	1.12	1.14	1.16	1.18	1.20	1.23	1.25	1.28	1.30	1.32	1.38	1.43	1.48	1.53	1.58

EXAMPLE: Determine Equivalent "Standard Air" for use in System Performance Calculations:

$$\text{Standard Air} = \frac{\text{Specified CFM}}{\text{Correction Factor}}$$

**TABLE II
AIR FRICTION LOSS**

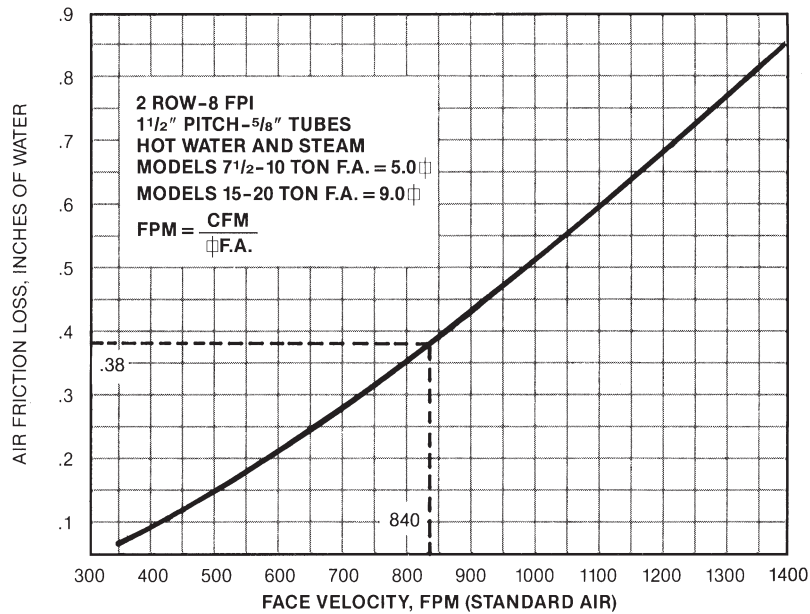

AIR HANDLER ACCESSORIES (con't)

STEAM COILS

**CURVE 1
STEAM COIL CAPACITY**

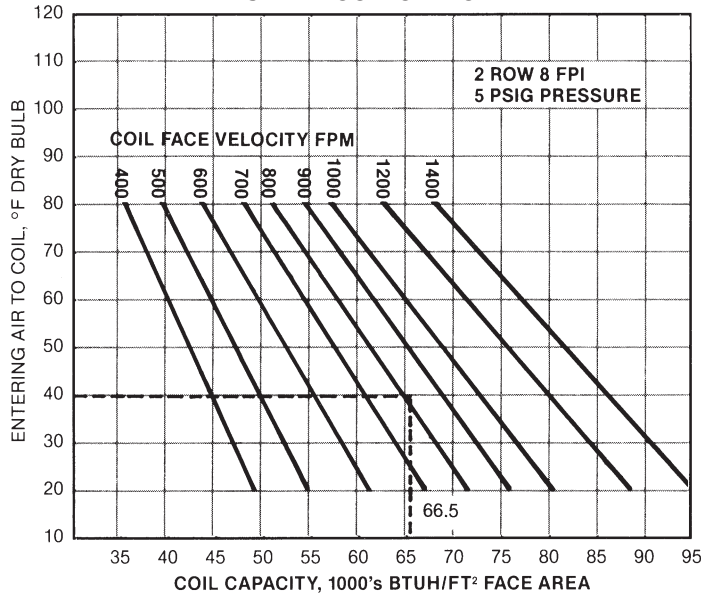

TEMPERATURE OF STEAM AT VARIOUS PRESSURES

Approximate Gauge Pressure (lbs.)	2	5	10	15	20	30
Temperature °F	218	227	240	250	259	275

TABLE III

STEAM PR., PSIG	FACTOR
2	.96
5	1.00
10	1.06
15	1.11
20	1.16
30	1.24

Steam Coil Capacity, factors are based on 5 PSIG Steam Pressure. For other conditions use the adjacent correction factors.

BASIC FORMULA:

$$\text{Air Temperature Rise, } ^\circ\text{F} = \frac{\text{BTUH}}{1.08 \times \text{CFM}}$$

STEAM COIL SELECTION:

Specified:

Steam @ 30 PSIG
Entering Air Temp. @ 40°F Dry Bulb
5000 CFM @ 6000 Ft. Elevation

Select 10 Ton Nominal Coil:

Face Area = 5 Ft²
Circuits = 12

Determine Coil Performance:

From Table I (page 21), Altitude and Temperature Correction Factor = 1.19
Std. CFM = 5000/1.19 = 4202
Face Velocity = 4202/5 = 840 FPM
From Curve 1, BTUH/Ft = 66,500
Coil Capacity = 5 x 65,000 = 325,000 BTUH
From Table III, Steam Correction Factor = 1.24
Total Coil Capacity = 1.24 x 325,000 = 403,000 BTUH
Air Temp. Rise = 403,000/(1.08 x 4202) = 90.85°F
From Table II, Air Side Pressure Drop = .38" H₂O

FILTER RACK

The filter rack accessory can be connected directly to the hot water/steam coil accessory. The filter rack accessory is ONLY needed when hot water steam coils are used.

MODEL NO.	AIR HANDLER SIZES USE ON	IN. [mm]					
		A	B	C	D	E	F
RXHF-B74A	090, 120	51 ¹ / ₂ [1308]	24 [610]	25 ¹ / ₈ [638]	47 ³ / ₈ [1203]	197 ⁷ / ₈ [505]	2 ¹ / ₁₆ [52]
RXHF-B76A	180, 240	59 ¹ / ₂ [1511]	34 ¹ / ₂ [876]	27 [686]	55 ¹ / ₂ [1410]	30 ¹ / ₂ [775]	2 [51]

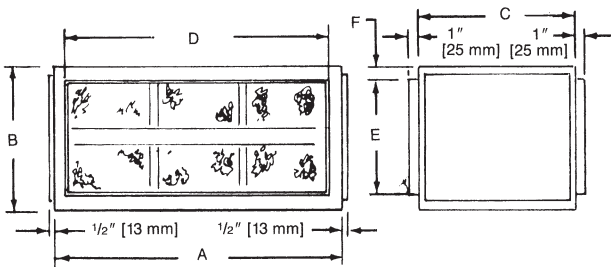

FILTER PRESSURE DROP:

MODEL NO.	CFM [L/s] x 1000 [472]									
	2	3	4	5	6	7	8	9	10	
RXHF-B74A	.01 [2]	.02 [4]	.03 [7]	.07 [16]	.10 [22]	.15 [33]	—	—	—	
RXHF-B76A	—	—	—	—	.05 [11]	.06 [13]	.10 [22]	.12 [27]	.15 [33]	

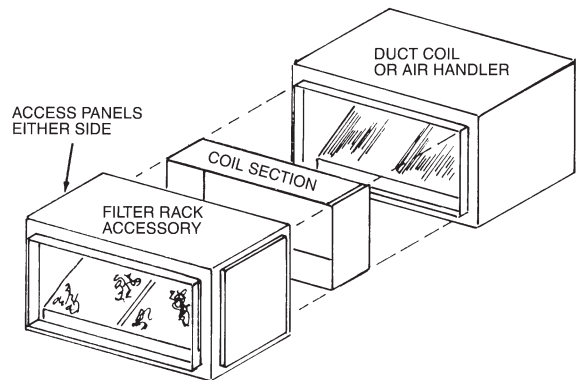

MODEL NO.	FILTER SIZE (QTY.) TYPE
RXHF-B74A	16x20x1 (4) Disposable 20x20x1 (2) Disposable
RXHF-B76A	20x25x1 (6) Disposable

[] Designates Metric Conversions

AIR HANDLER ACCESSORIES (con't)

UNIT WITH ACCESSORIES

7.5 THROUGH 10 NOMINAL TONS [26 THROUGH 35 kW]

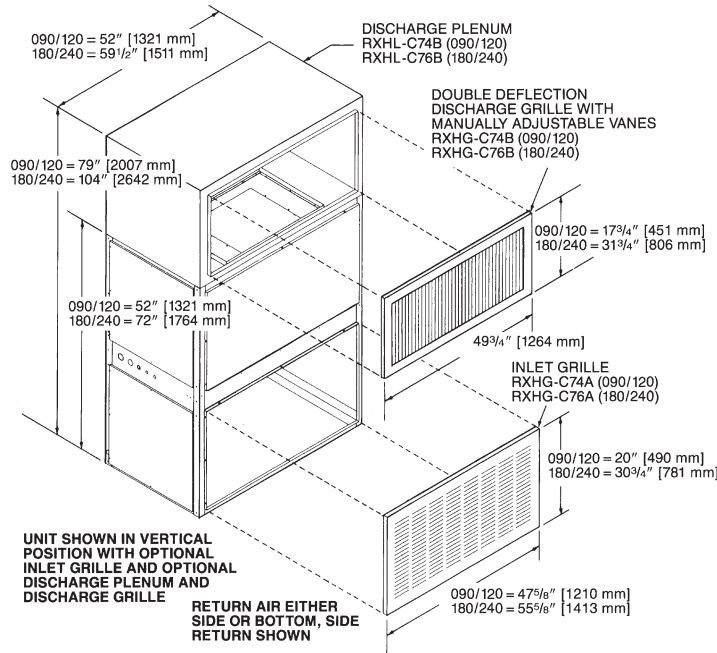

DOUBLE DEFLECTION DISCHARGE GRILLE

MODEL NO.	AIR HANDLER SIZES USED ON	NOMINAL CFM [L/s]	FT. [m] OF THROW
RXHG-C74B	090	3000 [1416]	0° DEFLECTION - 43' [13.1]
			22° DEFLECTION - 37' [11.3]
			45° DEFLECTION - 22' [6.7]
RXHG-C76B	180	4000 [1888]	0° DEFLECTION - 53' [16.2]
			22° DEFLECTION - 46' [14]
			45° DEFLECTION - 27' [8.2]
RXHG-C76B	240	6000 [2831]	0° DEFLECTION - 52' [15.8]
			22° DEFLECTION - 36' [11]
			45° DEFLECTION - 18' [5.5]
RXHG-C76B	240	8000 [3775]	0° DEFLECTION - 65' [19.8]
			22° DEFLECTION - 45' [13.7]
			45° DEFLECTION - 22' [6.7]

TYPICAL APPLICATION

7.5, 10, 15 AND 20 NOMINAL TONS
[26, 35, 53 AND 70 kW]

OPTIONAL ELECTRICAL HEATER KIT SHOWN INSTALLED IN HORIZONTAL POSITION AND CONNECTED DIRECTLY TO THE AIR HANDLER. THE HEATER KIT MAY ALSO BE INSTALLED WITH THE AIR HANDLER SET IN THE VERTICAL POSITION. IN EITHER POSITION THE HEATER KIT CONTROL COMPARTMENT MUST BE ON THE LEFT SIDE FACING THE AIR DISCHARGE OPENING.

FOUR HEAVY GAUGE ANGLES ARE FURNISHED (SHIPPED LOOSE) FOR SUSPENDING UNITS FROM ALL FOUR CORNERS, MINIMUM OF 1/2" [13] SUPPORT RODS ARE RECOMMENDED. IF ALL-THREAD IS USED, IT IS ALSO RECOMMENDED THAT TWO NUTS AND TWO LOCKWASHERS BE TIGHTENED SECURELY AGAINST THE SUSPENSION ANGLES.

WHEN HOT WATER OR STEAM COIL, MIXING BOX OR DISCHARGE AIR PLENUM ACCESSORIES ARE REQUIRED, UNITS CANNOT BE SUSPENDED AS ILLUSTRATED. AN ALTERNATE SUSPENSION METHOD SUCH AS ANGLES OR CHANNELS (FIELD SUPPLIED) SHOULD BE LOCATED UNDER UNIT. (SHOWN BELOW)

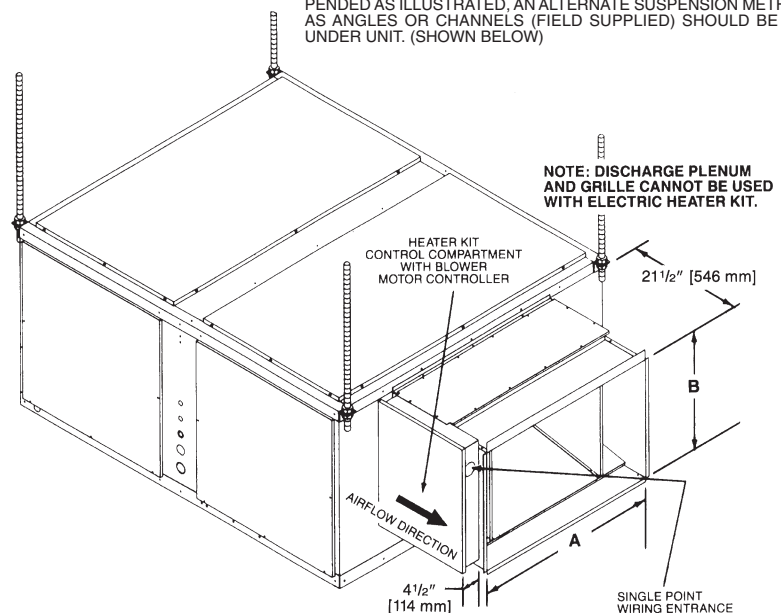

MODEL NO.	AIR HANDLERS SIZES USED ON	IN. [mm]	
		A	B
RXHE-DE****A	090, 120	20 [508]	20 [508]
RXHE-CE****C	180, 240	36 [914]	24 [610]

THE BOTTOM OF THE AIR HANDLER SHOULD BE SLOPED IN TWO PLANES THAT PITCH THE CONDENSATE TO THE DRAIN CONNECTION. THE DRAIN PAN SHOULD NOT LEAVE PUDDLES LARGER THAN 2 INCHES IN DIAMETER AND 1/8 INCH DEEP FOR MORE THAN 3 MINUTES.

[] Designates Metric Conversions

MIXING BOX ACCESSORY—OPERATING SEQUENCE

COOLING SEASON—Thermostat set at “Cool” and “Fan Auto,” outside air damper goes to “minimum fresh air” position when cooling thermostat closes, energizing mechanical cooling. When cooling thermostat is satisfied, mechanical cooling is de-energized, and outside air damper closes.

INTERMEDIATE SEASON—Same as for cooling season, except that cooling thermostat closes, starting indoor blower motor, the enthalpy control, mounted on outside air, determines if “free” cooling or mechanical cooling should be utilized. If outside air conditions are suitable for cooling, the mechanical cooling remains off and the mixed air controller modulates the damper motor to assume the proper damper position to maintain mixed air setting. If outside conditions

are not suitable for cooling, then the dampers go to “minimum fresh air” position and mechanical cooling is energized.

HEATING SEASON—Damper always stays at “minimum fresh air” position while fan motor is operating. Outside air damper closes when blower motor is off. “Minimum fresh air” position must not allow mixed air temperatures to air handler below 50°F. [10°C] during heating seasons.

CAUTION: IT IS NOT RECOMMENDED THAT HOT WATER OR STEAM COILS BE USED WITH THE MIXING BOX ACCESSORY WITHOUT A SUITABLE FREEZE-STAT TO PREVENT THE POSSIBILITY OF FREEZING THE COIL.

MIXING BOX

MODEL NO.	AIR HANDLER SIZES USED ON	FLANGED DUCT OPENINGS		IN. [mm]
		LENGTH IN. [mm]	WIDTH IN. [mm]	“X”
RXHM-BC74H	090, 120	42 [1067]	16 ⁷ / ₈ [454]	27 [686]
RXHM-BC76H	180, 240	48 ³ / ₈ [1229]	22 [559]	32 [813]

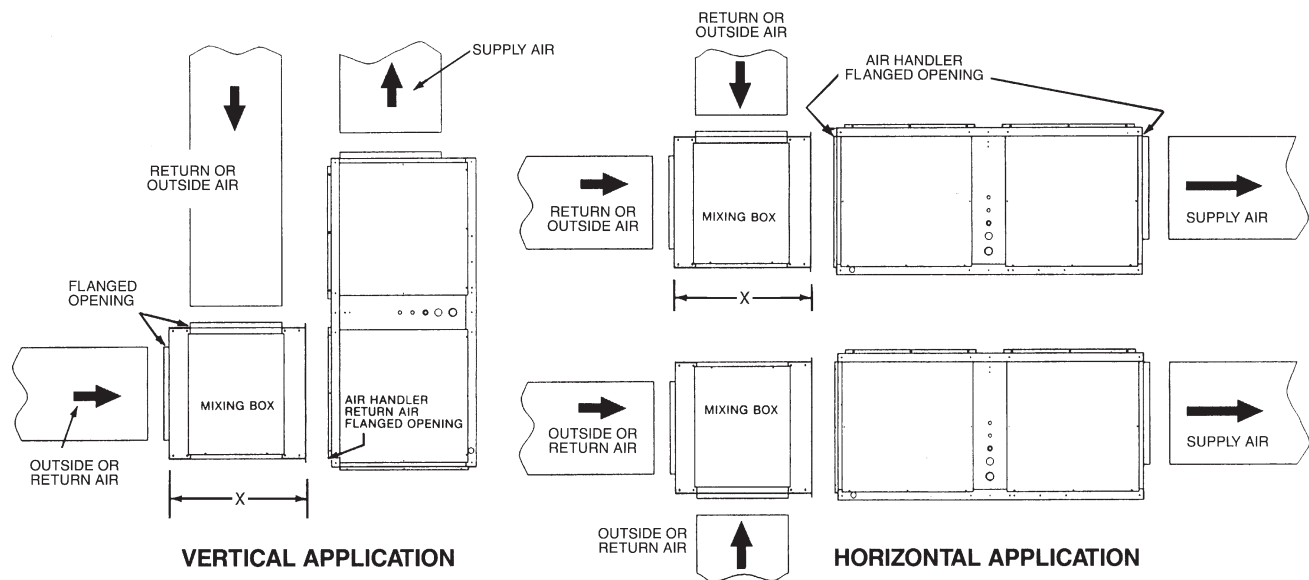

[] Designates Metric Conversions

TYPICAL PIPING RECOMMENDATIONS

INDOOR COIL ABOVE OUTDOOR UNIT

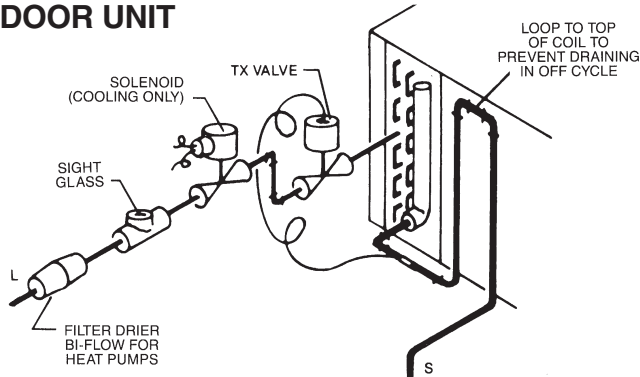

INDOOR COIL BELOW OUTDOOR UNIT

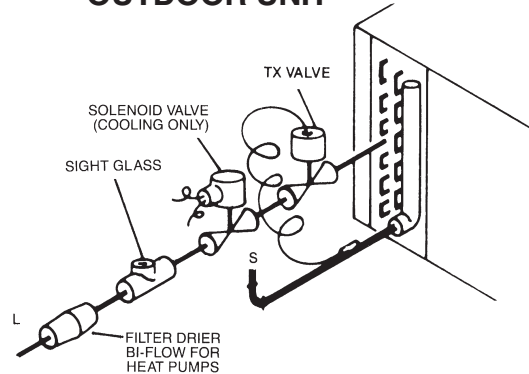

NOTE: PIPING ACCESSORIES SHOWN SHOULD BE MOUNTED AS CLOSE TO AIR HANDLING UNIT AS POSSIBLE.

The 7.5 [26 kW] and 10 [35 kW] Air Handlers are designed as two (2) circuit, full face equal distribution coils. As shipped from the factory, the suction and liquid lines are dual circuits. Copper fittings are supplied in the unit to field manifold the suction and liquid lines for single circuit.

NOTE: The expansion valve bulbs must be secured to the corresponding suction lines. The circuits are marked accordingly. See illustration under Typical Piping recommendations for additional information.

When dual straight cool condensing units are used refer to the refrigerant piping size charts for the individual condensing unit piping.

REFRIGERANT PIPING (See Tables at Right)

The following will be of help in accomplishing a successful installation.

1. Size liquid line for no more than 50 PSIG [345 kPa] pressure drop.
2. Size suction lines for no more than 2°F [1.1°C] loss which corresponds to approximately 5 PSIG [34 kPa] pressure drop.
3. When indoor unit is installed below outdoor unit, do not exceed the recommended vapor line O.D. This will insure adequate velocities for proper oil return.
4. Install strainer-drier and sight glass in liquid line.
5. Pitch all horizontal suction lines downward in the direction of flow for cooling only applications.
6. Locate the outdoor unit and indoor unit as close together as possible to minimize piping runs.
7. A liquid line solenoid installed just ahead of the expansion valve is recommended for cooling only applications. Be sure condensing unit is suitable for pump down.
8. Piping runs between condenser and evaporator not to exceed 150' [46 m] linear length (90' [27 m] linear length for heat pumps).

NOTE: Refer to suction and liquid line pressure drop charts found in condensing unit and remote heat pump literature.

CONDENSATE DRAIN PIPING

- Consult local codes or ordinances for specific requirements regarding condensate drain.
- Condensate drain is open to atmosphere and must be trapped. Trap must be at least 3 inches [76 mm] deep and made of flexible material or fabricated to prevent freeze-up.
- Pitch the drain line at least 1/4 inch [6 mm] per foot away from the drain pan.
- Do not reduce the drain line size from the connection size provided on the unit.
- Do not connect the drain line to a closed sewer line.

PIPING SIZES 090 & 120

LINEAR LENGTH, FT. [m]	LIQUID LINE O.D., IN. [mm]		SUCTION LINE O.D., IN. [mm]	
	090	120	090	120
0-50 [0-15]	1/2 [13]	5/8 [16]	1 1/8 [29]	1 3/8 [35]
51-100* [16-30]	1/2 [13]	5/8 [16]	1 3/8 [35]	1 5/8 [41]
101-150 [31-46]	1/2 [13]	5/8 [16]	1 3/8 [35]	1 5/8 [41]

*For cooling only, refer to remote heat pump literature for piping recommendations.

PIPING SIZES 180 & 240

LINEAR LENGTH, FT. [m]	LIQUID LINE O.D., IN. [mm]		SUCTION LINE O.D., IN. [mm]	
	180	240	180	240
0-50 [0-15]	3/4 [19]	7/8 [22]	1 3/8 [35]	1 5/8 [41]
51-100 [16-30]	3/4 [19]	7/8 [22]	1 5/8 [41]	2 1/8 [54]
101-150 [31-46]	3/4 [19]	7/8 [22]	2 1/8 [54]	2 1/8 [54]

EQUIVALENT LENGTH, FT. [m] OF STRAIGHT TYPE "L" TUBING FOR NON-FERROUS VALVES AND FITTINGS (BRAZED)

TUBE SIZE INCHES O.D. [mm]	SOLE-NOID VALVE	ANGLE VALVE	SHORT RADIUS ELL	LONG RADIUS ELL	TEE LINE FLOW	TEE BRANCH FLOW
1/2 [13]	12 [3.7]	8.3 [2.5]	1.6 [0.5]	1.0 [0.3]	1.0 [0.3]	3.1 [0.9]
5/8 [16]	15 [4.6]	10.4 [3.2]	1.9 [0.8]	1.2 [0.4]	1.2 [0.4]	3.6 [1.1]
3/4 [19]	18 [5.5]	12.5 [3.8]	2.1 [0.7]	1.4 [0.4]	1.4 [0.4]	4.2 [1.3]
7/8 [22]	21 [6.4]	14.8 [4.4]	2.4 [0.7]	1.6 [0.5]	1.6 [0.5]	4.8 [1.5]
1 1/8 [29]	12 [3.7]	18.8 [5.7]	3.0 [0.9]	2.0 [0.6]	2.0 [0.6]	6.0 [1.8]
1 3/8 [35]	15 [4.6]	22.9 [7.0]	3.6 [1.1]	2.4 [0.7]	2.4 [0.7]	7.2 [2.2]
1 5/8 [41]	18 [5.5]	27.1 [8.3]	4.2 [1.3]	2.8 [0.8]	2.8 [0.8]	8.4 [2.6]
2 1/8 [54]	21 [6.4]	35.4 [10.8]	5.3 [1.6]	3.5 [1.1]	3.5 [1.1]	10.7 [3.3]

[] Designates Metric Conversions



OPERATING SEQUENCE

NOTE: Please refer to specification sheets covering RAWL- condensing units for operating sequence.

GUIDE SPECIFICATIONS

Furnish and install as shown on the drawing Rheem Model _____ draw through air handler suitable for both horizontal and vertical applications. The entire assembly shall be UL and cUL listed with the cooling (and heat pump heating) capacity AHRI Certified.

DRIVE PACKAGE—A complete drive package shall be factory or field installed. Package shall consist of a 3450 RPM dual voltage, single phase open drip proof motor or a 3 phase 1750 RPM open drip proof internally protected motor, not requiring an external starter. Variable pitch motor sheave, fixed pitch fan sheave, and belt.

COILS—Coils shall be fabricated of $\frac{3}{8}$ " [10 mm] O.D. seamless copper tubing expanded into aluminum fins. All coils shall be submitted to an air pressure test of up to 550 PSIG [2068 kPa] under water after fabrication and dehydrated prior to assembly in unit. Units shall be shipped with a nitrogen holding charge. Airflow shall be draw through design providing uniform air distribution across the coil surface.

BLOWER, BEARINGS AND SHAFT—Fans shall be a double width, double inlet, forward curve, centrifugal type, statically and dynamically balanced, and constructed of galvanized steel. They shall be mounted on $\frac{3}{4}$ " [19 mm] = 7.5 ton [26 kW] & 10 ton [35 kW], diameter solid shafts made of high carbon steel, centerless ground and polished, supported by resilient mounted sealed bearings.

DRAIN PAN—The drain pan shall be manufactured of zinc coated steel. The pan shall have internally threaded pipe size drain connections and shall be designed to accept condensate in either horizontal or vertical type applications on either side of unit.

FILTERS—Filter mounting hardware shall be designed to accept up to 2" [51 mm] filters for field replacement. One inch [25 mm] throw away filters shall be furnished with the unit.

CABINET—Cabinets shall be manufactured of galvanized steel subjected to multi-stage cleaning and finished with powder coat paint. Units shall have removable service access panels on each side and top.

INSULATION—Cabinets shall be insulated with $\frac{1}{2}$ " [13 mm] by 1 $\frac{1}{2}$ pound [.68 kg] density fiberglass insulation coated with neoprene and bonded to the cabinet surface with a U.L. approved adhesive. Insulation shall have fire retarding characteristics in accordance with smoke developed rating not to exceed 50 and flame spread rating of 25 per Underwriters Laboratories testing procedures.

FACTORY TESTING—In addition to the pre-assembly testing mentioned above, each coil shall be leak tested after assembly into the unit. While under pressure, the coil shall be leak tested using an Electronic Leak Detector.

ELECTRIC HEATERS—UL and cUL listed electric heater kits shall be available in a wide range of capacities. All kits shall offer two stages of capacity, blower motor controller and single point connection. Heater kits shall be available for installation directly on the supply fan discharge for either horizontal or vertical application.

MIXING BOX—Mixing box accessory shall be available for mixing return air with outside air before entering the air handler. The accessory shall include both return and outside air dampers and economizer controls factory mounted. Economizer controls shall include enthalpy and mixed air sensors and damper motors. Mixing box accessory shall be available for installation to the return air section of the air handler for either horizontal or vertical applications.

DISCHARGE PLENUM AND GRILLE—Shall be available for vertical application. Discharge grille shall provide manually adjustable double deflection discharge vanes.

RETURN AIR GRILLES—Shall be provided for vertical return applications.

HOT WATER OR STEAM COILS—Shall be available for field installation. All coils shall be tested to 300 psi. Coils shall be available for either horizontal or vertical air handler applications.

[] Designates Metric Conversions

GENERAL TERMS OF LIMITED WARRANTY*

Rheem will furnish a replacement for any part of this product which fails in normal use and services within the applicable periods stated below, in accordance with the terms of the limited warranty.

Any PartOne (1) Year

*For Complete Details of the Limited Warranty, Including Applicable Terms and Conditions, See Your Local Installer or Contact the Manufacturer for a Copy.

Before proceeding with installation, refer to installation instructions packaged with each model, as well as complying with all Federal, State, Provincial, and Local codes, regulations, and practices.

**Rheem Heating,
Cooling and
Water Heating**

P.O. Box 17010, Fort Smith, AR 72917



"In keeping with its policy of continuous progress and product improvement, Rheem reserves the right to make changes without notice."