



SPECIFICATIONS  
**ASLC12HSG**  
 EXHAUST FAN HOUSING

**Exhaust Fan with Light Housing**

• **Fan Housing**

23 gauge galvanized metal housing.  
 Dimensions 7<sup>3</sup>/<sub>8</sub>" x 7<sup>5</sup>/<sub>8</sub>" x 5<sup>7</sup>/<sub>8</sub>".

• **Duct Collar**

Plastic collar for 4" duct connection, comes complete with built in non-metallic back draft damper for quiet operation.

• **Unit Mounting**

Rated Type IC for ceilings insulated to R-40. Designed to mount in ceilings with at least 6" of clearance. The unit will mount directly to the joist or using the supplied mounting bars with a rough in opening of 7<sup>3</sup>/<sub>8</sub>" x 7<sup>7</sup>/<sub>8</sub>". The housing will mount through drywall thickness up to 3/4".

• **Electrical Connections**

1/2" electrical knockouts provided.

• **Available Trim Kits**

**ASLC50MBG:** 50 CFM  
**ASLC70MBG:** 70 CFM

• **Shipping Info**

Number of Housings in Box: 12  
 UPC Code: 083162225115

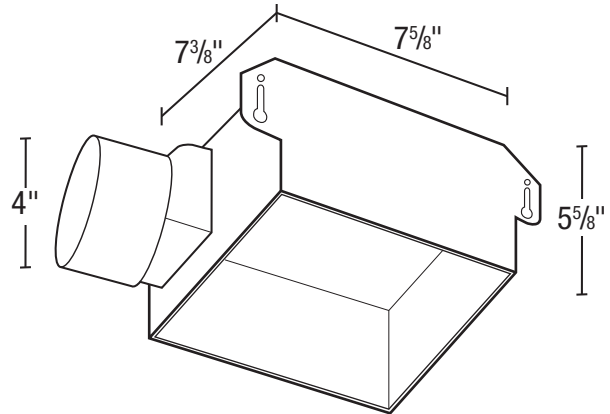

**Housing ONLY. Must be combined with ASLCMBG series trim kit (sold separately)**

<b>PROJECT</b>					<b>ARCHITECT</b>				
<b>LOCATION</b>					<b>ENGINEER</b>				
<b>CONTRACTOR</b>					<b>SUBMITTED BY</b>			<b>DATE</b>	
<b>FAN NUMBER</b>	<b>MODEL NUMBER</b>	<b>CFM</b>	<b>IN W.G.</b>	<b>RPM</b>	<b>WATTS</b>	<b>AMPS</b>	<b>SONES</b>	<b>QTY</b>	<b>OPTIONAL EQUIPMENT &amp; REMARKS</b>



820 Lincoln Avenue  
 West Chester, Pennsylvania 19380-4466  
 Tel: (610) 692-7400 • 877-304-3785  
 Fax: (610) 696-8048