



THE ORIGINAL™

0.5/0.95 GPF Dual Flush Toilet Elongated Bowl with 12" Rough-In



THE ORIGINAL™

0.5/0.95 GPF DUAL FLUSH TOILET

Elongated Bowl with 12" Rough-In

FEATURES

- Quiet, powerful flush delivered with a patented Stealth® flush chamber and air transfer system
- Reliable standard Fluidmaster fill valve
- One flush thoroughly evacuates the bowl every time, eliminating double flushing
- Smooth, low friction ceramic surface helps achieve a clear bowl every time
- Two-piece toilet
- Easy-to-use flush buttons
- No flapper to cause leakage
- Meets ADA Height Requirements

SPECIFICATIONS



Materials: Vitreous China **Finish Color:** White

Codes/Standards:

ASME A112.19.2/CSA B45.1

DOE - Energy Policy Act 1992

California Energy Commission (CEC)

MEASUREMENTS

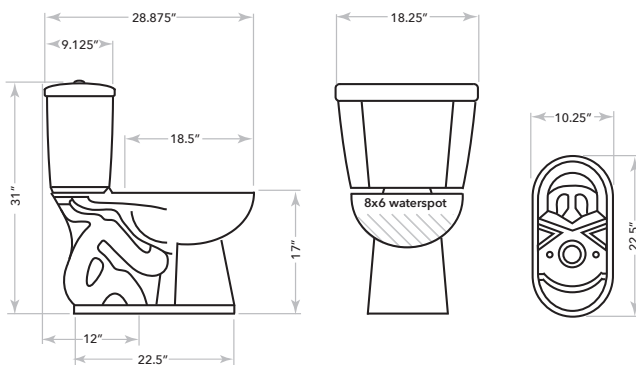

BULK PACKAGING

N7717 Elongated Bowl

UPC Code 732291771733

Packaging Type Kraft Corrugated

Packaging Dimensions 16" W
17.5" H
29.5" D

Packaging Weight 53 lbs

Skid Quantity 18 or 12

N7714-DF Tank

UPC Code 732291000239

Packaging Type Kraft Corrugated

Packaging Dimensions 9.5" W
17" H
19" D

Packaging Weight 37 lbs

Skid Quantity 30

*LIMITED LIFETIME WARRANTY on vitreous china products. Toilet tank trim: fill valve and flush valve assembly and plumbing fittings are warranted for a period of fifteen (15) years to the purchaser from the date of purchase. Call Niagara Conservation™ for complete warranty details.

CORPORATE HQ 1200 Lakeside Parkway, Suite 450, Flower Mound, Texas 75028 USA

© 2019 Niagara Conservation January 29, 2020 8:57 AM

To place an order, please contact:

(p) 800.831.8383 (f) 682.200.6962 (e) info@niagaracorp.com

niagaracorp.com