

FIGURE 601C CARBON STEEL BALL VALVES



2 PC FULL PORT 150# FLANGED

FEATURES

- Full port
- 150 WSP
- Flanged connection
- TFM 1600 + 20% GF seats
- Stainless steel trim
- Anti-static design
- Blowout-proof stem
- Investment cast body
- Adjustable packing
- Locking device
- Direct mounting pad
- Manufactured silicone free
- Fire safe
- Sizes 1/2" – 8"



PRODUCT SPECIFICATIONS

Standards

- Design: ASME B16.34
- Pressure Test: API 598
- Flange Dimensions: ASME B16.5
- Materials: ASME B16.34
- Mounting Pad: ISO 5211
- NACE MR0103 and MR0175 compliant
- Fugitive Emissions: ISO 15848-1 and TA-Luft
- API 607 Approved (7th Edition)

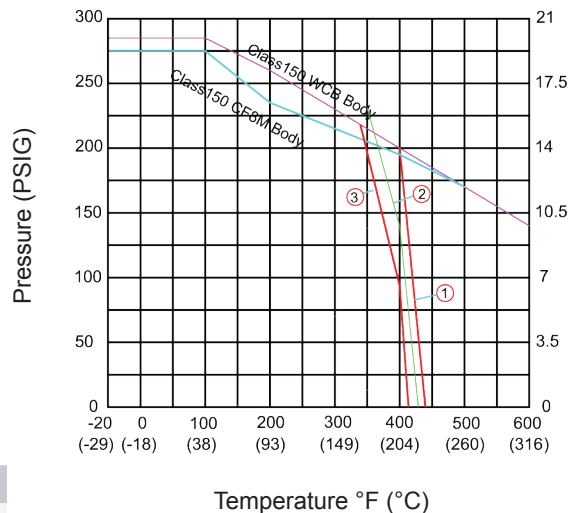

FIGURE NUMBER MATRIX

FNW 601C	F	Size	
	Fire Safe	Size Code	
	D = 1/2"	L = 2-1/2"	
	F = 3/4"	M = 3"	
	G = 1"	P = 4"	
	J = 1-1/2"	U = 6"	
	K = 2"	X = 8"	

REPAIR KITS (ORDER SEPARATELY)

FNW 600CFRKTFM	Size	
	Size Code	
D = 1/2"	L = 2-1/2"	
F = 3/4"	M = 3"	
G = 1"	P = 4"	
J = 1-1/2"	U = 6"	
K = 2"	X = 8"	

CV & WEIGHT TORQUE (IN-LBS)

Size	Cv	Wt (lbs)	Torque (in-lbs)		
			75 psig 5 Bar	150 psig 10 Bar	300 psig 20 Bar
1/2"	30	3.52	53	53	53
3/4"	55	4.71	62	62	62
1"	96	6.34	97	97	106
1-1/2"	270	12.98	186	186	212
2"	470	18.66	265	283	310
2-1/2"	750	30.14	425	442	478
3"	1150	38.61	690	699	788
4"	2100	65.52	1062	1071	1186
6"	5000	163.00	2973	2982	3310
8"	9500	282.00	3929	4186	4743

Note: 30% safety factor is recommended when sizing actuator.

FIGURE 601C CARBON STEEL BALL VALVES



2 PC FULL PORT 150# FLANGED

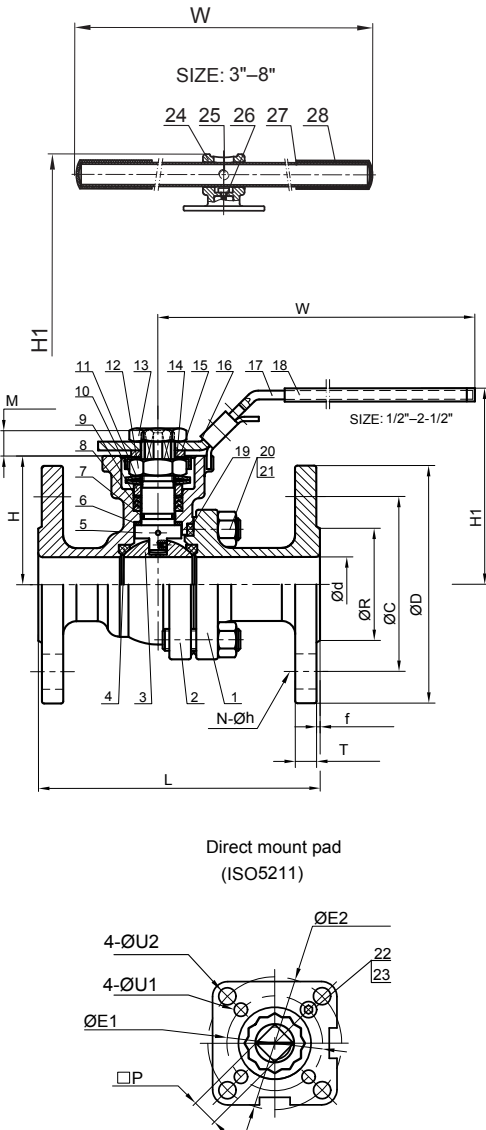

STANDARD MATERIALS

Ref #	Description	Material
1	End Cap	WCB
2	Body	WCB
3	Ball	CF8M
4	Ball Seat	TFM1600+20% GF
5	Stem (Anti-Static Device)	316
6	Thrust Washer	TFM4215
7	O-Ring	FKM
8	Packing	Graphite
9	Bushing	304
10	Gland	316
11	Belleville Washer	301
12	Stem Nut	A194-8 (304)
13	Handle Nut (1/2"–2-1/2")	A194-8 (304)
14	Stop-Lock-Cap	304
15	Handle Gland	304
16	Lock Device (1/2"–2-1/2")	304
17	Handle (1/2"–2-1/2")	304
18	Handle Sleeve (1/2"–2-1/2")	Vinyl Plastic
19	Body Gasket	316 Spiral Wound + Graphite
20	Bolt Nut	A194-8
21	Bolting	A193-B8
22	Stop Bolt	A2-70
23	Stop Nut	A2-70
24	Handle Adapter (3"–8")	CF8
25	Set Screw (3"–8")	A2-70
26	Bolting (3"–8")	A2-70
27	Pipe Handle (3"–8")	A53+Zn Plated
28	Handle Sleeve (3"–8")	Vinyl Plastic

DIMENSIONS

Size	d	L	R	D	C	T	f	N	h	H	H1	M	P	U1	U2	E1	E2	W	ISO 52111	Weight (lbs)
1/2"	0.59	4.25	1.38	3.50	2.38	0.31	0.06	4	5/8	1.93	3.11	0.30	0.354	0.24	0.24	1.42	1.65	5.77	F03–F04	3.52
3/4"	0.79	4.62	1.69	3.88	2.75	0.34	0.06	4	5/8	2.09	3.31	0.35	0.354	0.24	0.28	1.42	1.97	5.77	F03–F05	4.71
1"	0.98	5.00	2.01	4.25	3.12	0.38	0.06	4	5/8	2.32	3.54	0.43	0.433	0.24	0.28	1.65	1.97	6.95	F04–F05	6.34
1-1/2"	1.50	6.50	2.88	5.00	3.88	0.50	0.06	4	5/8	2.99	4.33	0.55	0.551	0.28	0.35	1.97	2.76	7.75	F05–F07	12.98
2"	1.97	7.00	3.62	6.00	4.75	0.56	0.06	4	3/4	3.23	4.53	0.55	0.551	0.28	0.35	1.97	2.76	7.75	F05–F07	18.66
2-1/2"	2.50	7.50	4.12	7.00	5.50	0.62	0.06	4	3/4	4.02	5.91	0.67	0.669	0.35	0.43	2.76	4.02	10.5	F07–F10	30.14
3"	2.99	8.00	5.00	7.50	6.00	0.69	0.06	4	3/4	4.41	6.93	0.67	0.669	0.35	0.43	2.76	4.02	11.9	F07–F10	38.61
4"	3.94	9.00	6.19	9.00	7.50	0.88	0.06	8	3/4	5.51	8.31	0.87	0.866	non	0.43	non	4.02	15.8	F07–F10	65.52
6"	5.91	15.5	8.50	11.0	9.50	0.94	0.06	8	7/8	7.99	11.18	1.06	1.063	0.55	non	4.92	non	31.6	F12	163.00
8"	7.97	18.0	10.63	13.5	11.75	1.06	0.06	8	7/8	9.96	13.15	1.06	1.063	0.55	non	4.92	non	31.6	F12	282.00